



Designation: ~~D7649~~—~~10~~ **D7649 – 10 (Reapproved 2017)**

Standard Test Method for Determination of Trace Carbon Dioxide, Argon, Nitrogen, Oxygen and Water in Hydrogen Fuel by Jet Pulse Injection and Gas Chromatography/Mass Spectrometer Analysis¹

This standard is issued under the fixed designation D7649; the number immediately following the designation indicates the year of original adoption or, in the case of revision, the year of last revision. A number in parentheses indicates the year of last reapproval. A superscript epsilon (ϵ) indicates an editorial change since the last revision or reapproval.

1. Scope

1.1 This test method describes a procedure primarily for the determination of carbon dioxide, argon, nitrogen, oxygen and water in high pressure fuel cell grade hydrogen by gas chromatograph/mass spectrometer (GC/MS) with injection of sample at the same pressure as sample without pressure reduction, which is called “Jet Pulse Injection”. The procedures described in this method were designed to measure carbon dioxide at 0.5micromole per mole (ppmv), Argon 1 ppmv, nitrogen 5 ppmv and oxygen 2 ppmv and water 4 ppmv.

1.2 The values stated in SI units are standard. The values stated in inch-pound units are for information only.

1.3 The mention of trade names in standard does not constitute endorsement or recommendation for use. Other manufacturers of equipment or equipment models can be used.

1.4 *This standard does not purport to address all of the safety concerns, if any, associated with its use. It is the responsibility of the user of this standard to establish appropriate safety and health practices and determine the applicability of regulatory limitations prior to use.*

1.5 *This international standard was developed in accordance with internationally recognized principles on standardization established in the Decision on Principles for the Development of International Standards, Guides and Recommendations issued by the World Trade Organization Technical Barriers to Trade (TBT) Committee.*

2. Referenced Documents

2.1 *Other Standards:*

SAE TIR J2719 Information Report on the Development of a Hydrogen Quality Guideline for Fuel Cell Vehicles April 2008²

3. Terminology

3.1 *Definitions of Terms Specific to This Standard:*

3.1.1 *absolute pressure*—pressure measured with reference to absolute zero pressure, usually expressed as kPa, mm Hg, bar or psi. All the pressures mentioned in this method are absolute pressure.

3.1.2 *constituent*—A component (or compound) found within a hydrogen fuel mixture.

3.1.3 *contaminant*—impurity that adversely affects the components within the fuel cell system or the hydrogen storage system by reacting with its components. An adverse effect can be reversible or irreversible.

3.1.4 *dynamic calibration*—calibration of an analytical system using calibration gas standard generated by diluting known concentration compressed gas standards with hydrogen, as used in this method for carbon dioxide, argon, nitrogen and oxygen (7.3 and 7.4).

3.1.5 *extracted ion chromatogram (EIC)*—a GC/MS chromatogram where a selected ion is plotted to determine the compound(s) of interest.

3.1.6 *fuel cell grade hydrogen*—hydrogen satisfying the specifications in SAE TIR J2719.

¹ This test method is under the jurisdiction of ASTM Committee D03 on Gaseous Fuels and is the direct responsibility of Subcommittee D03.14 on Hydrogen and Fuel Cells.

Current edition approved Dec. 1, 2010 April 1, 2017. Published February 2011 April 2017. Originally approved in 2010. Last previous edition approved in 2010 as D7649-10. DOI: ~~10.1520/D7649-10~~ 10.1520/D7649-10R17.

² Available from SAE International (SAE), 400 Commonwealth Dr., Warrendale, PA 15096-0001, <http://aerospace.sae.org>.

- 3.1.7 *hydrogen fuel*—hydrogen to be tested without compositional change due to sample introduction, etc.
- 3.1.8 *jet pulse injection*—high pressure hydrogen fuel sample is introduced instantaneously at the same pressure into GC/MS.
- 3.1.9 *relative humidity*—ratio of actual pressure of existing water vapor to maximum possible pressure of water vapor in the atmosphere at the same temperature, expressed as a percentage.
- 3.1.10 *response factor (RF)*—the amount in volume (μL) of an analyte divided by the EIC area of the analyte.
- 3.1.11 *static calibration*—calibration of an analytical system using standards in a matrix, state or manner different than the samples to be analyzed, as used in this method for water concentration in hydrogen.
- 3.2 *Acronyms:*
 - 3.2.1 *FCV*—fuel cell vehicle.
 - 3.2.2 *PEMFC*—proton exchange membrane fuel cell.

4. Summary of Test Method

4.1 The simultaneous analysis of carbon dioxide, argon, nitrogen, oxygen and water at 0.5 – 5 ppmv (micromole per mole) in hydrogen fuel samples from fueling stations is challenging due to high hydrogen fuel sample pressure and possible contaminations from ambient air.

4.2 In this method, a small stainless steel loop is initially pressurized with high pressure hydrogen standard or sample without any pressure regulation or restriction (“Sample Loop Pressurization”, Fig. 1). The hydrogen in the loop is then released entirely as a “jet pulse” into a T-union which splits sample into a 0.25 μm ID 30 m long capillary column and an electronic flow controller (EFC) used to vent excess hydrogen to the atmosphere (“Jet Pulse Injection”, Fig. 2). Less than 1% of hydrogen enters the capillary column with the remaining sample venting to atmosphere through EFC. As demonstrated in Appendix X1, the hydrogen volume “jet pulse injected” into the capillary column is a constant volume and independent of the sample loop pressure when the sample loop pressure is over 90 psi. Therefore, the constant hydrogen volume from standards or samples is GC/MS analyzed in regardless of standard or sample pressures.

4.3 Jet pulse injected volume into the capillary column is approximate 100 μL (In Appendix X1, this volume is calculated to be 115 μL under the analytical conditions described in Appendix X1). When a 2-mL of sample loop is pressurized to 200 psi, the hydrogen in the loop is $(200 \text{ psi}/14.7\text{psi}) \times 2 \text{ mL}$ or 27 mL. Hence, 99.5% of the hydrogen sample vents to atmosphere. This type of “Jet Pulse Injection” has been found acceptable for the analysis of high pressure hydrogen fuel sample since the hydrogen volume injected is independent of the pressures of hydrogen standards or samples. Consequently it is unnecessary to regulate standards and hydrogen samples to the same pressure. In addition to possible trace leaks or air trapped inside, regulators are not recommended as moisture on the regulator surface can be released into the sample resulting in a high moisture determination.

4.4 A mass spectrometer provides sensitive and selective detection towards carbon dioxide, argon, nitrogen, oxygen and water.

<https://standards.iteh.ai/catalog/standards/sist/1440f91-d66a-41c3-b844-3c76253df4a8/astm-d7649-102017>

Figure 1 Sample Loop Pressurization

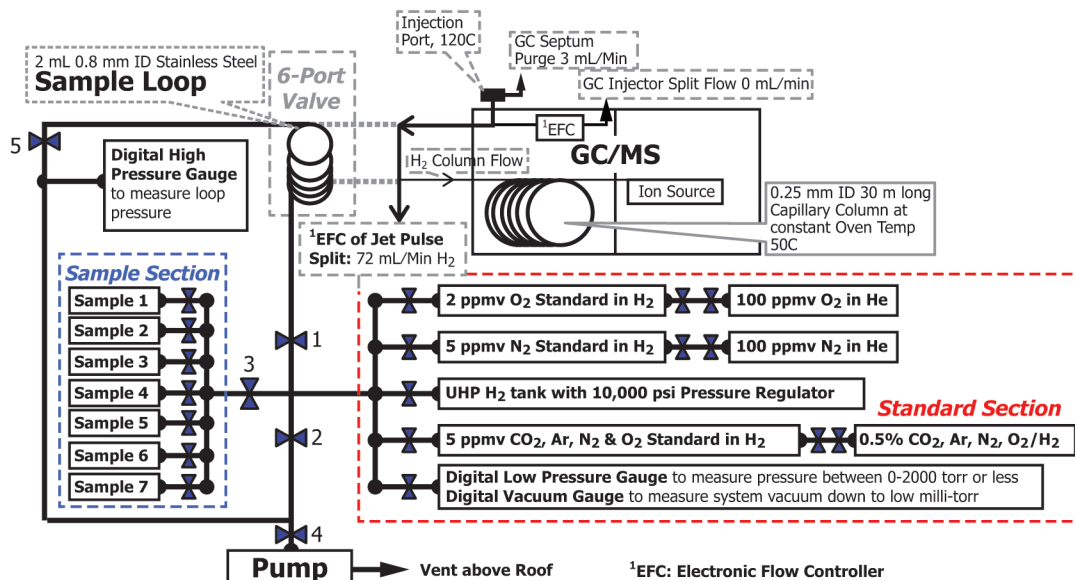

FIG. 1 Sample Loop Pressurization

Figure 2 Jet Pulse Injection

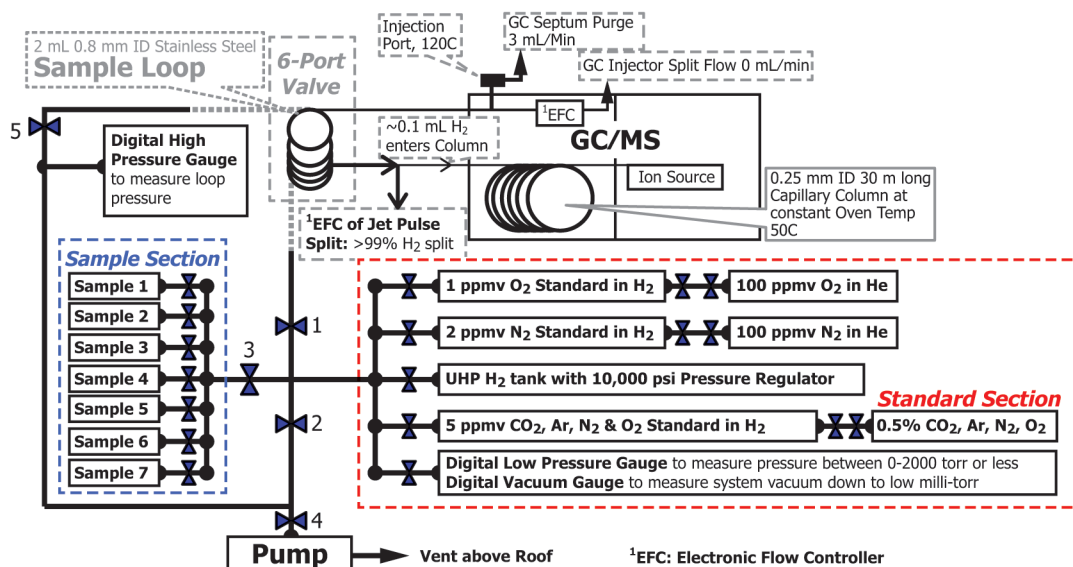

FIG. 2 Jet Pulsed Injection

5. Significance and Use

5.1 Low operating temperature fuel cells such as proton exchange membrane fuel cells (PEMFCs) require high purity hydrogen for maximum performance. The following are the reported effects (SAE TIR J2719) of the compounds determined by this test method.

5.2 *Carbon Dioxide (CO₂)*, acts largely as a diluent, however in the fuel cell environment CO₂ can be transformed into CO.

5.3 *Water (H₂O)*, is an inert impurity, as it does not affect the function of a fuel cell stack; however, it provides a transport mechanism for water-soluble contaminants, such as Na⁺ or K⁺. In addition, it may form ice on valve internal surface at cold weather or react exothermally with metal hydride used as hydrogen fuel storage.

5.4 *Inert Gases (N₂ and Ar)*, do not normally react with a fuel cell components or fuel cell system and are considered diluents. Diluents can decrease fuel cell stack performance.

5.5 *Oxygen (O₂)*, in low concentrations is considered an inert impurity, as it does not adversely affect the function of a fuel cell stack; however, it is a safety concern for vehicle on board fuel storage as it can react violently with hydrogen to generate water and heat.

6. Apparatus

6.1 *Mass Spectrometer (MS)*—The MS can perform mass calibration with a scanning range from m/e 15 to 650. The background peak intensities of water, nitrogen, argon, oxygen and carbon dioxide in the mass spectrum of FC-43 (perfluorotributylamine), used for mass calibration, should be less than 10% of m/e 69 to demonstrate a background acceptable for the determination of these analytes before beginning sample analysis. All analytes determined according to this method have a molecular mass less than 44 amu; therefore, the mass scanning range of m/e 15 to 50 is typically used.

6.2 *Data System*—A computer or other data recorder loaded with appropriate software for data acquisition, data reduction, and data reporting and possessing the following capabilities is required:

- 6.2.1 Graphic presentation of the total ion chromatogram (TIC) and extracted ion chromatogram (EIC).
- 6.2.2 Digital display of chromatographic peak areas.
- 6.2.3 Identification of peaks by retention time and mass spectra.
- 6.2.4 Calculation and use of response factors.
- 6.2.5 External standard calculation and data presentation.

6.3 *Gas chromatography (GC)*—Chromatographic system capable of obtaining retention time repeatability of 0.05 min (3 s) throughout the analysis.

6.3.1 *Interface with MS*—A heated interface connecting the GC column to the MS ion source.

6.3.2 *GC Column*—A 0.25mm ID 30m 0.25 μm film thickness DB-5 column has been successfully used to perform this analysis. Other capillary columns may be used provided chromatographic peaks do not significantly tail. One end of the GC column is connected to the Jet Pulse Split (6.4.5) and the other end is connected to the ion source inlet of a mass spectrometer.

6.3.3 *Carrier Gas*—Ultra high purity hydrogen is used as carrier gas. Use of helium carrier gas results in unacceptable broadening of the water chromatographic peak. An example of water peaks is shown in Fig. 3.

6.3.4 *GC Injector*—An injector port with a glass insert and a septum is connected through a 1/16 in. OD stainless steel tubing to a jet pulse split (6.4.5) in the inlet system (6.4). The injector temperature is set to at 220°C to ensure that all water vapor in injected ambient air are not condensed in the injector. The GC column and total split flow rate are electronically set at 1.5 and 75 mL/min, respectively. The GC total split flow includes a GC septum purge flow of 3mL/min (Fig. 1 and Fig. 2) and GC injector split flow of 72mL/min.

6.4 *Inlet System*—A system introduces high pressure samples or standards into GC/MS for analysis. The sample or standard enter the inlet system through “Sample Loop Pressurization” (Fig. 1) and then leave the inlet system to GC/MS through “Jet Pulse Injection” (Fig. 2). While the inlet system is in “Sample Loop Pressurization”, the sample loop (6.4.4) is pressurized directly with hydrogen samples or calibration standards without pressure regulation or flow restriction. Afterwards, a six-port sample valve (6.4.1) switches the inlet system to “Jet Pulse Injection”, in which pressurized hydrogen in the sample loop is released instantaneously onto the GC column (6.3.2) and jet pulse split (6.4.5). Since the sample pressure is high, all parts of the inlet system must be capable of working at pressures of 1500 psi or higher.

6.4.1 *Six Ports Valve*—This valve is used to switch from “Sample Loop Pressurization” (Fig. 1) to “Jet Pulse Injection” (Fig. 2).

6.4.2 *Samples and Calibration Standards*—All calibration standards and samples are prepared or collected in 1800 psi pressure rated containers with a DOT 3A1800 label (United States Department of Transportation mandated label) affixed to the outside surface. All calibration standards and samples are connected to the inlet system before beginning an analytic sequence to minimize the potential for air or moisture contamination due to addition or replacement of standard or sample containers.

6.4.3 *Vacuum Pump*—an oil vacuum pump that can pump down to 50 mtorr or less.

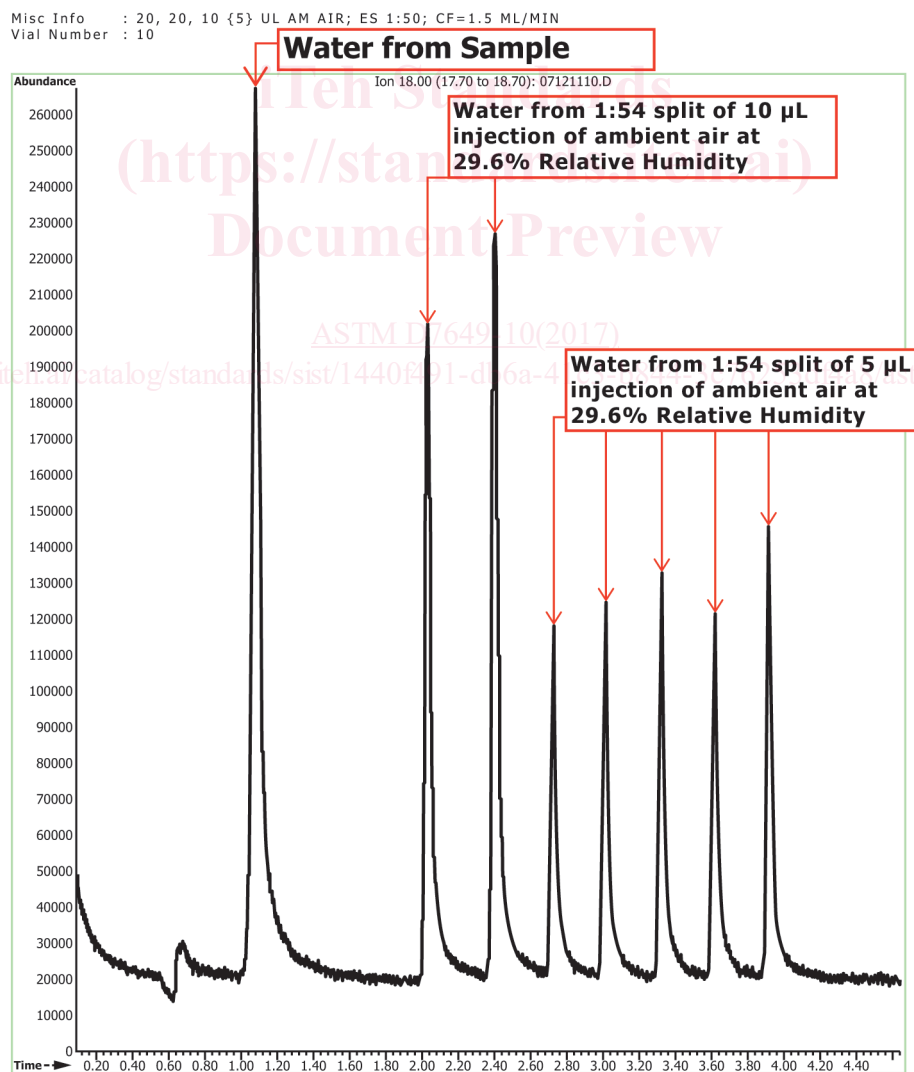

FIG. 3 m/e18 Extracted Ion Chromatogram of Sample Analysis with Co-Injection of Ambient Air

6.4.4 *Sample Loop*—stainless steel tubing with $\frac{1}{16}$ in. OD and 2 mL inside volume. Both ends of the sample loop are connected to a six port valve (6.4.1).

6.4.5 *Jet Pulse Split*—a T-union connects the following three portions.

6.4.5.1 Six port valve (6.4.1)

6.4.5.2 Inlet of GC column (6.4.2)

6.4.5.3 Inlet of an electronic flow controller (EFC) with its outlet to ambient air. The flow rate of this EFC is always electronically set at 150mL/min to vent most of the GC injector split flow (72mL/min) during “Sample Loop Pressurization” (Fig. 1) and released hydrogen from pressurized sample loop in “Jet Pulse Injection” (Fig. 2).

6.4.6 *Digital Vacuum Gauge*—capable of measuring absolute pressure at vacuum range 0 to 12,000 milli-torr (mtorr or 10^{-3} torr). For the vacuum range from 0 to 1000 mtorr, the accuracy is $\pm 10\%$ or ± 10 mtorr, whichever is larger.

6.4.7 *Digital Pressure Gauges*—Two types of digital pressure gauges are required. A pressure gauge 0 to 1000 psig is used to measure sample and standard final pressure. Another digital pressure gauge in the low and narrow pressure range, such as 0 to 2000 torr, is used to measure the pressure of pure gases in initial standard preparation.

6.4.8 *Pressure Regulator*—A 10,000 psi pressure regulator is used to reduce UHP hydrogen pressure to approximate 400 psi for calibration standard preparation. It is also used to pressurize the inlet system during method blank analysis, and during inlet system flushing.

7. Reference Standards

7.1 Typical reference standards are listed in Fig. 1. Two standards prepared in helium containing 100 ppmv O_2 and 100 ppmv N_2 , are commercial available. Remaining standards listed in Fig. 1 are prepared as per below.

7.2 *0.5% CO_2 , Ar, N_2 and O_2 in hydrogen*—An evacuated 1-L cylinder is connected to four pressure-regulated compressed gas cylinders containing reagent or UHP grade CO_2 , Ar, N_2 and O_2 . The system is evacuated to less than 500 mtorr with all the regulators opened and the main cylinder valves closed. With the system isolated from vacuum pump, the 1-L cylinder valve is opened and 100 torr of each target compound from the compressed gas cylinders is expanded into the system and 1-L cylinder. The 1-L cylinder is then pressured using UHP hydrogen to 390 psi, or $390/14.7 \times 760 = 2.02 \times 10^4$ torr. The concentration of each target compound is $100 \text{ torr} / (2.02 \times 10^4 \text{ torr}) = 0.5\%$. This standard can be used as a co-injection standard (9.3.3) and further diluted to prepare a 5 ppmv standard (7.3). The UHP hydrogen used for preparation of both 0.5% (7.2) and 5 ppmv standards (7.3) are free from CO_2 , Ar, N_2 and O_2 by this test method.

7.3 *5ppmv CO_2 , Ar, N_2 and O_2 in hydrogen:*

7.3.1 Close all the valves in Fig. 1 except leave Valves 2, 4 and both valves of the cylinder labeled with “5 ppmv CO_2 , Ar, N_2 & O_2 Standard in H_2 ” open. Evacuate the “Standard Section” in Fig. 1 to less than 100 mtorr.

7.3.2 Close Valve 2 and pressurize the “Standard Section” in Fig. 1 to above 100 psi by UHP hydrogen.

7.3.3 Open Valve 2 and pump the “Standard Section” in Fig. 1 to less than 100 mtorr and then close it.

7.3.4 Close the valve of the standard cylinder close to the 0.5% standard and open the valve of the cylinder containing the 0.5% CO_2 , Ar, N_2 and O_2 in hydrogen for about 10 s and then close it.

7.3.5 Open the valve of the standard cylinder close to the 0.5% standard for 5 s and close it. Measure the pressure by the digital pressure gauge in Fig. 1.

7.3.6 Pressurize the “Standard Section” in Fig. 1 to less than 400 psi with UHP H_2 with 10,000 psi pressure regulator and close the other valve of the standard cylinder.

7.3.7 The concentration of the standard is calculated as following. If the pressure in 7.3.5 is 20 torr and final pressure 385 psi (7.3.6), the concentration is $(20 \text{ torr} \times (0.50/100)) / (385/14.7 \times 760) = 5.0$ ppmv.

7.3.8 Low concentration standards other than 5 ppmv can be prepared and used as calibration standards.

7.4 *Detection Limit Standards of Oxygen and Nitrogen*— ~ 2 ppmv O_2 and ~ 5 ppmv N_2 in hydrogen. The preparation of these two standards from commercially available 100 ppmv O_2 and N_2 in helium, respectively, is in the same as that for 5ppmv CO_2 , Ar, N_2 and O_2 in hydrogen (7.3). The detection limit standards are analyzed in each analytical sequence to validate acceptable detection of oxygen and nitrogen at the detection limit.

8. Preparation of Apparatus

8.1 *GC/MS*—Place in service in accordance to the manufacturer’s instructions. Perform daily mass calibration using FC-43. As stated in 6.1, each of the peak intensities of m/e 18, 28, 29, and 32 should be less than 10% of m/e 69 in the mass spectrum of FC-43 used for mass calibration. In order to achieve this condition, the GC column flow rate of GC/MS system should be set at a high flow rate, such as, 2mL/min, while the system is in standby mode to remove any air in the carrier gas line. In addition, when any air may be introduced into the carrier gas system, such as when changing the hydrogen carrier gas tank, the GC total split flow rate is set at 100mL/min for an hour to rapidly remove air in the carrier gas line.

9. Procedure

9.1 The detailed procedures used to perform jet pulse injection followed by GC/MS analysis are listed below. The procedures are split into two sections – sample loop pressurization (Fig. 1) and jet pulse injection/GC/MS analysis (Fig. 2).

9.2 Sample Loop Pressurization (Fig. 1):

9.2.1 With all the valves closed in Fig. 1, Valves 2, 3 and 4 are opened and pumped down including both standard and sample sections to less than 100 mtorr. If this pressure cannot be lowered to at least 100 mtorr, perform a leak check.

9.2.2 Open Valves 1 and 5 and close Valves 2 and 4, followed with pressurization of the sample loop with UHP hydrogen to 300 – 400 psi.

9.2.3 Open Valve 4 only to pump down the entire system to less than 10 torr and then open Valve 2 to less than 1 torr. Simultaneously, measure the flow rate from EFC of the jet pulse split (6.4.5); this should be close to 72 mL/min.

9.2.4 Close both Valves 2 and 4 and pressurize the entire system with standard or sample and measure the loop pressure using a digital high pressure gauge as depicted in Fig. 1. For safety reason, it is recommended that the loop pressure not be over 500 psi. For the method blank analysis using UHP hydrogen, the loop should be pressurized to approximate 400 psi.

9.3 Jet Pulse Injection/GC/MS Analysis (Fig. 2):

9.3.1 Switch the six port valve to “Jet Pulse Injection” (Fig. 2) and simultaneously start GC/MS acquisition.

9.3.2 Measure the GC injector split flow rate, which should be 0 mL/min since most injector split flow vents out from the jet pulse split (6.4.5). Measure the GC septum purge flow, which should be approximate 3 mL/min.

9.3.3 After 1.5 minutes from the start of GC/MS acquisition, the 0.5% CO₂, Ar, N₂ and O₂ in hydrogen (6.2), 1% CO₂ in nitrogen or ambient air is co-injected three times and 18 seconds apart. The volume and time interval of co-injections can be varied, for example, those in Table X1.1 of Appendix X1. The reasons for co-injection are listed under “Co-Injection” of Appendix X1. Each GC/MS analysis is completed in less than 5 minutes.

9.3.4 A typical analytic sequence is shown in Table 1. As shown in this table, except for the method blank, each standard or sample is analyzed consecutively three times. The three analyses of each standard or sample should generate the same extracted ion chromatogram (EIC) areas of target compounds within analytical error, as described in Appendix X1; this demonstrates that the jet pulse injected the same volume of each hydrogen standard or sample. The EIC of target compounds are m/e44 for CO₂, 40 Ar, 29 N₂, 32 O₂ and 18 H₂O. In general, the variation of EIC areas of 5 ppmv CO₂, Ar, N₂ and O₂ in hydrogen (7.3) in three consecutive analyses in the analytical sequence (Table 1) are less than 10% RSD for CO₂ and Ar. For N₂ and O₂, the %RSD should be less than 30% due to the baseline noise of GC/MS analysis.

10. Calculation

10.1 The concentrations of carbon dioxide, argon, nitrogen and oxygen in hydrogen sample can be calculated from the EIC areas of carbon dioxide at m/e44, argon m/e40, nitrogen m/e29, and oxygen m/e32 using Eq 4. See Fig. 4.

TABLE 1 Analytical Sequence^A

#	Analytical Sequence ^B	Co-Injection
1	UHP Hydrogen – This analysis must be repeated if any target compound is over the detection limits	10, 10 & 10µL 0.5% CO ₂ , Ar, N ₂ and O ₂ in H ₂ (7.2)
2	Detection Limit Standard of O ₂ - 2 ppmv O ₂ in H ₂	10, 10 & 10µL 0.5% CO ₂ , Ar, N ₂ and O ₂ in H ₂ (7.2)
3	Detection Limit Standard of O ₂ - 2 ppmv O ₂ in H ₂	5, 5 & 5µL commercially available standard, such as, 1% CO ₂ in N ₂ ; it is used to compare the RF of CO ₂ from 0.5% CO ₂ , Ar, N ₂ and O ₂ in H ₂ (7.2) and also used to demonstrate the syringe used is free from water before injection of ambient air in next analysis, water must not be detected at this co-injection.
4	Detection Limit Standard of O ₂ - 2 ppmv O ₂ in H ₂	10, 5 & 2µL Ambient Air. The 2µL injection of ambient air is detection limit standard.
5	Detection Limit Standards of N ₂ - 5 ppmv N ₂ in H ₂	10, 10 & 10µL 0.5% CO ₂ , Ar, N ₂ and O ₂ in H ₂ (7.2)
6	Detection Limit Standards of N ₂ - 5 ppmv N ₂ in H ₂	5, 5 & 5µL 1% CO ₂ in N ₂ ; water must not be detected at this co-injection before injection of ambient air in next analysis.
7	Detection Limit Standards of N ₂ - 5 ppmv N ₂ in H ₂	10, 5 & 2µL Ambient Air. The 2µL injection of ambient air is detection limit standard.
8	5 ppmv CO ₂ , Ar, N ₂ and O ₂ in hydrogen (7.3)	10, 10 & 10µL 0.5% CO ₂ , Ar, N ₂ and O ₂ in H ₂ (7.2)
9	5 ppmv CO ₂ , Ar, N ₂ and O ₂ in hydrogen (7.3)	5, 5 & 5µL 1% CO ₂ in N ₂ ; water must not be detected at this co-injection before injection of ambient air in next analysis
10	5 ppmv CO ₂ , Ar, N ₂ and O ₂ in hydrogen (7.3)	10, 5 & 2µL Ambient Air. The 2µL injection of ambient air is detection limit standard
11	UHP Hydrogen – This analysis must be repeated if any target compound is over detection limits	10, 10 & 10µL 0.5% CO ₂ , Ar, N ₂ and O ₂ in H ₂ (7.2)
12	Sample #1	10, 10 & 10µL 0.5% CO ₂ , Ar, N ₂ and O ₂ in H ₂ (7.2)
13	Sample #1	5, 5 & 5µL 1% CO ₂ in N ₂ ; water must not be detected at this co-injection before injection of ambient air in the next analysis
14	Sample #1	10, 5 & 2µL Ambient Air. The 2µL injection of ambient air is detection limit standard.

••• The additional samples are analyzed as Sample #1.

^A Percentage relative humidity and atmospheric pressure are measured during each analysis for water concentration calculation by Eq 4 and Eq 5.

^B The co-injection starts after 1.5 minutes from the beginning of GC/MS acquisition. Three consecutive co-injections are injected at 18 seconds apart. However, different volumes and numbers of co-injections at different time intervals can be used, such as the example in Table X1.1 in Appendix X1.