



Designation: ~~D6928~~—~~10~~ **D6928 – 17**

Standard Test Method for Resistance of Coarse Aggregate to Degradation by Abrasion in the Micro-Deval Apparatus¹

This standard is issued under the fixed designation D6928; the number immediately following the designation indicates the year of original adoption or, in the case of revision, the year of last revision. A number in parentheses indicates the year of last reapproval. A superscript epsilon (ϵ) indicates an editorial change since the last revision or reapproval.

1. Scope

- 1.1 This test method covers a procedure for testing coarse aggregate for resistance to abrasion using the Micro-Deval apparatus.
- 1.2 The values stated in SI units are to be regarded as standard. No other units of measurement are included in this standard.
- 1.3 The text of this method references notes and footnotes which provide explanatory material. These notes and footnotes (excluding those in tables and figures) shall not be considered as requirements of the test method.
- 1.4 *This procedure may involve hazardous materials, operations, and equipment. This standard does not purport to address all of the safety concerns, if any, associated with its use. It is the responsibility of the user of this standard to establish appropriate safety and health practices and determine the applicability of regulatory limitations prior to use.*
- 1.5 *This international standard was developed in accordance with internationally recognized principles on standardization established in the Decision on Principles for the Development of International Standards, Guides and Recommendations issued by the World Trade Organization Technical Barriers to Trade (TBT) Committee.*

2. Referenced Documents

2.1 *ASTM Standards:*²

[C136 Test Method for Sieve Analysis of Fine and Coarse Aggregates](#)

[C670 Practice for Preparing Precision and Bias Statements for Test Methods for Construction Materials](#)

[E11 Specification for Woven Wire Test Sieve Cloth and Test Sieves](#)

3. Terminology

3.1 *Definitions:*

3.1.1 *constant mass, n*—the condition of a test sample dried at a temperature of $110 \pm 5^\circ\text{C}$ such that it will not lose more than 0.1 % moisture after 2 h of drying.

¹ This test method is under the jurisdiction of ASTM Committee D04 on Road and Paving Materials and is the direct responsibility of Subcommittee D04.51 on Aggregate Tests.

Current edition approved June 1, 2010/April 1, 2017. Published June 2010/April 2017. Originally approved in 2003. Last previous edition approved in 2008/2010 as D6928 – 08/10. DOI: [10.1520/D6928-10.1520/D6928-17](https://doi.org/10.1520/D6928-10.1520/D6928-17).

² For referenced ASTM standards, visit the ASTM website, www.astm.org, or contact ASTM Customer Service at service@astm.org. For *Annual Book of ASTM Standards* volume information, refer to the standard's Document Summary page on the ASTM website.

3.1.1.1 *Discussion*—

Such a condition of dryness can be verified by determining the mass of the sample before and after successive 2-h drying periods. In lieu of such a determination, samples may be considered to have reached constant mass when they have been dried at a temperature of $110 \pm 5^\circ\text{C}$ for an equal or longer period than that previously found adequate for producing the desired constant mass condition under equal or heavier loading conditions of the oven.

4. Summary of Test Method

4.1 The Micro-Deval Test~~test~~ is a measure of abrasion resistance and durability of mineral aggregates resulting from a combination of actions including abrasion and grinding with steel balls in the presence of water. A sample with standard grading is initially soaked in water for not less than ~~one hour~~ 1 h. The sample is then placed in a jar mill with 2.0 L of water and an abrasive charge consisting of 5000 g of 9.5-mm diameter steel balls. The jar, aggregate, water, and charge are revolved at 100 rpm for up

to 2 h, depending on the particle size. The sample is then washed and oven dried. The loss is the amount of material passing the 1.18-mm sieve expressed as a percent by mass of the original sample.

5. Significance and Use

5.1 The Micro-Deval abrasion test is a test of coarse aggregate to determine abrasion loss in the presence of water and an abrasive charge. Many aggregates are more susceptible to abrasion when wet than dry, and the use of water in this test incorporates this reduction in resistance to degradation in contrast to some other tests, which are conducted on dry aggregate. The test results are helpful in evaluating the toughness/abrasion resistance of coarse aggregate subject to abrasion when adequate information is not available from service records.

5.2 The Micro-Deval abrasion test is useful for detecting changes in properties of aggregate produced from an aggregate source as part of a quality control or quality assurance process.

6. Apparatus

6.1 *Micro-Deval Abrasion Machine*, a jar rolling mill capable of running at 100 ± 5 rpm (Fig. 1).

NOTE 1—Micro-Deval abrasion machine fitted with a counter may be used if the test is conducted on the basis of number of revolutions (Section 9.3.2).

6.2 *Containers*, stainless steel Micro-Deval abrasion jars having an approximate 5-L capacity, a locking cover and gasket capable of sealing the jar and making it ~~water-tight~~ watertight. External diameter of the abrasion jar shall be ~~194-mm~~ 194 mm to ~~202-mm~~ 202 mm and the internal height shall be ~~170-mm~~ 170 mm to ~~177-mm~~ 177 mm. The inside and outside surfaces of the jars shall be smooth and have no significant ridges or indentations (Fig. 1).

6.3 *Abrasive Charge*—Magnetic stainless steel balls are required. These shall have a diameter of 9.5 ± 0.5 mm. Each jar requires a charge of 5000 ± 5 g of balls.

6.4 *Sieves*, with square openings, and of the following sizes conforming to Specification E11 specifications: 19.0 mm, ~~16.0-mm~~, 16.0 mm, 12.5 mm, 9.5 mm, 6.7 mm, 6.3 mm, 4.75 mm, and 1.18 mm.

6.5 *Oven*, capable of maintaining a temperature of $110 \pm 5^\circ\text{C}$, ~~5 °C~~.

6.6 *Balance*, or scale accurate to 1.0 g.

7. Supplies

7.1 *Laboratory Reference Aggregate*—A supply of standard “Brechin Quarry No. 2” coarse aggregate available from the Soils and Aggregates Section, Materials Engineering Materials Office, Ministry of Transportation, 1201 Wilson Avenue, Downsview, Ontario, Canada M3M1J8. Fax: 1-416-235-4101.

7.1 *Calibration Reference Aggregate*—An adequate supply of aggregate, established by the ~~Laboratory~~ laboratory to use for ~~calibration~~ verification of the consistency of the test method (see 11.1).

8. Test Sample

8.1 The test sample shall be washed and ~~oven-dried~~ oven dried at $110 \pm 5^\circ\text{C}$, ~~5 °C~~ to constant mass, separated into individual size fractions in accordance with Test Method C136, and recombined to meet the grading as shown in 8.2, 8.3, or 8.4. In sections 8.3 and 8.4, the 6.7-mm sieve can be used in place of the 6.3-mm sieve when specified.

8.2 Aggregate for the test sample shall consist of material passing the 19.0-mm sieve, retained on the 9.5-mm sieve. An oven-dried sample of 1500 ± 5 g shall be prepared as follows:

Passing	Retained	Mass
19.0-mm	16.0-mm	375 g
16.0-mm	12.5-mm	375 g
12.5-mm	9.5-mm	750 g

8.3 In a case where the maximum nominal size of the coarse aggregate is 12.5 mm, a sample of 1500 ± 5 g shall be prepared as follows:

Passing	Retained	Mass
12.5-mm	9.5-mm	750 g
9.5-mm	6.3-mm	375 g
6.3-mm	4.75-mm	375 g

8.4 In a case where the maximum nominal size of the coarse aggregate is 9.5 mm or less, a sample 1500 ± 5 g shall be prepared as follows:

Passing	Retained	Mass
9.5-mm	6.3-mm	750 g
6.3-mm	4.75-mm	750 g

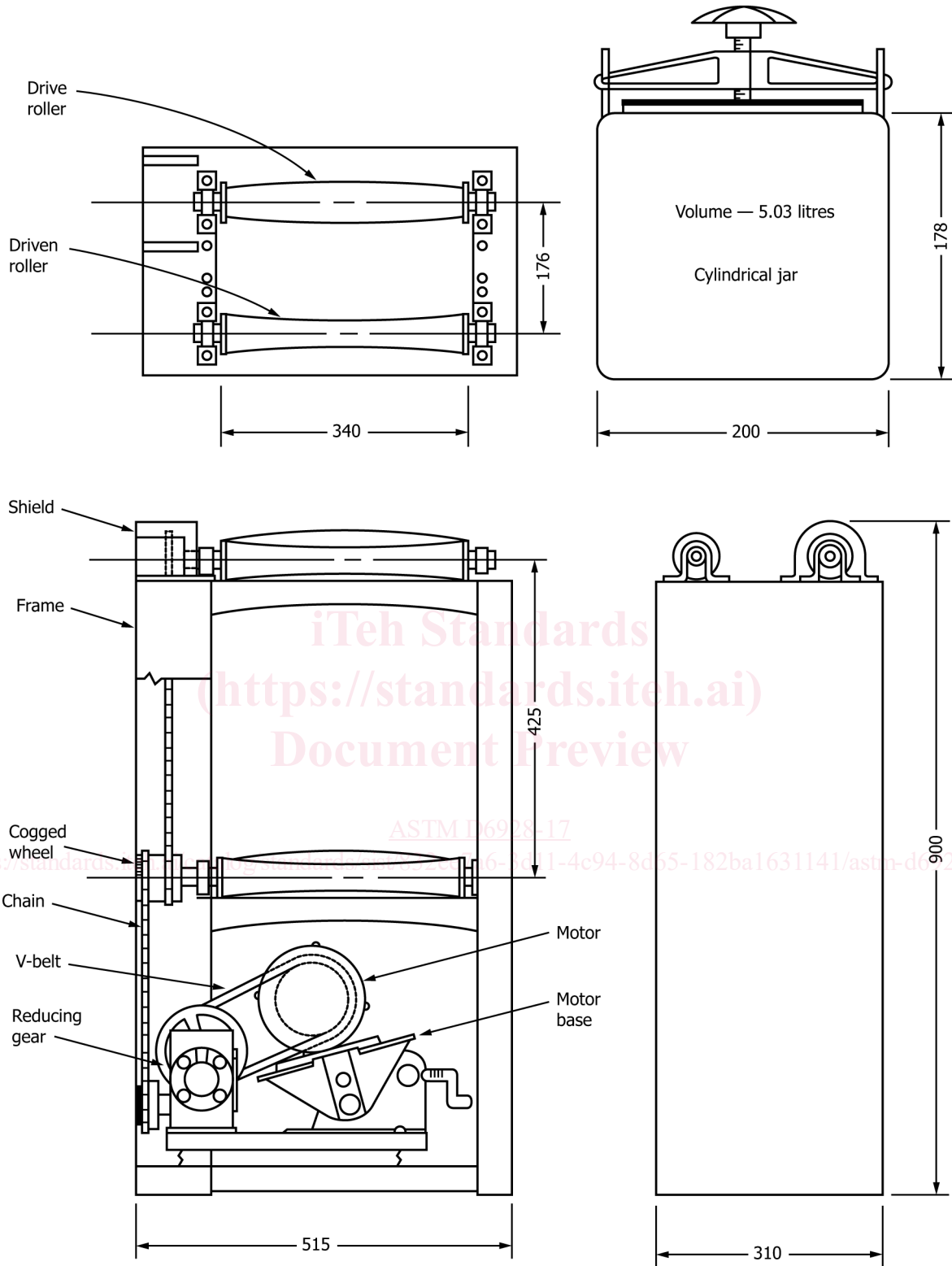

NOTE 1—Dimensions are in millimeters.

FIG. 1 Micro-Deval Abrasion Machine and Container (dimensions in mm)