



Designation: C170/C170M – 17

Standard Test Method for Compressive Strength of Dimension Stone¹

This standard is issued under the fixed designation C170/C170M; the number immediately following the designation indicates the year of original adoption or, in the case of revision, the year of last revision. A number in parentheses indicates the year of last reappraisal. A superscript epsilon (ϵ) indicates an editorial change since the last revision or reappraisal.

This standard has been approved for use by agencies of the U.S. Department of Defense.

1. Scope

1.1 This test method covers the sampling, preparation of specimens, and determination of the compressive strength of dimension stone.

1.2 The values stated in either SI units or inch-pound units are to be regarded separately as standard. The values stated in each system may not be exact equivalents; therefore, each system shall be used independently of the other. Combining values from the two systems may result in non-conformance with the standard.

1.3 *This standard does not purport to address all of the safety concerns, if any, associated with its use. It is the responsibility of the user of this standard to establish appropriate safety and health practices and determine the applicability of regulatory limitations prior to use.*

1.4 *This international standard was developed in accordance with internationally recognized principles on standardization established in the Decision on Principles for the Development of International Standards, Guides and Recommendations issued by the World Trade Organization Technical Barriers to Trade (TBT) Committee.*

2. Referenced Documents

2.1 *ASTM Standards:*²

[C39 Test Method for Compressive Strength of Cylindrical Concrete Specimens](#)

[C119 Terminology Relating to Dimension Stone](#)

[C1799 Guide to Dimension Stone Test Specimen Sampling and Preparation](#)

[D4543 Practices for Preparing Rock Core as Cylindrical Test Specimens and Verifying Conformance to Dimensional and Shape Tolerances](#)

[D7012 Test Methods for Compressive Strength and Elastic Moduli of Intact Rock Core Specimens under Varying States of Stress and Temperatures](#)
[E4 Practices for Force Verification of Testing Machines](#)

3. Terminology

3.1 *Definitions*—All definitions are in accordance with Terminology [C119](#).

4. Significance and Use

4.1 This test method is useful in indicating the differences in compressive strength between the various dimension stones. This test method also provides one element in comparing stones of the same type.

5. Apparatus

5.1 The testing machine used shall conform to the requirements of Test Method [C39](#), Section 5, including the calibration requirements of Practices [E4](#).

5.2 The testing machine used shall be capable of applying the required load at a uniform rate as prescribed in Section [9](#) and applying load in a steady manner as to avoid sudden or rapid load changes.

5.3 The spherical bearing block of the testing machine shall be suspended from the upper head so that the contact plate remains in a central position (spherical surfaces in full contact) when not loaded. The spherical surfaces shall be well lubricated, and the center of curvature shall be aligned within the surface of contact with the specimen.

5.4 [Fig. 1](#) illustrates the correct alignment of a specimen and the typical components of a testing machine conforming to these requirements.

6. Sampling

6.1 The sample shall be selected to represent a true average of the type or grade of stone under consideration and shall be of the quality supplied to the market in finished form under the type designation to be tested. The samples may be selected by the purchaser or his authorized representative from quarried stone or taken from the natural ledge and shall be of adequate size to permit the preparation of the desired number of test

¹ This test method is under the jurisdiction of ASTM Committee [C18](#) on Dimension Stone and is the direct responsibility of Subcommittee [C18.01](#) on Test Methods.

Current edition approved April 1, 2017. Published April 2017. Originally approved in 1941. Last previous edition approved in 2016 as C170/C170M-16. DOI: 10.1520/C0170_C0170M-17.

² For referenced ASTM standards, visit the ASTM website, www.astm.org, or contact ASTM Customer Service at service@astm.org. For *Annual Book of ASTM Standards* volume information, refer to the standard's Document Summary page on the ASTM website.

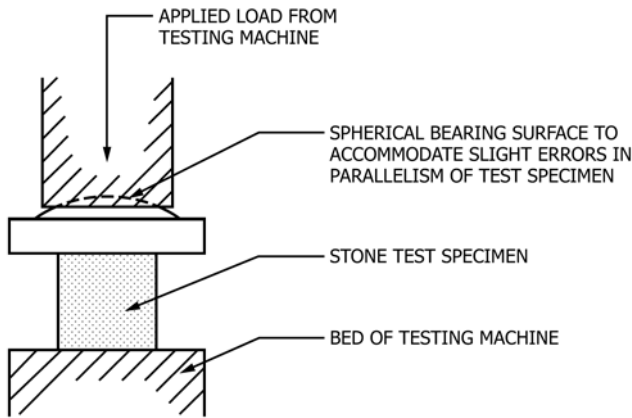

FIG. 1 Diagram of a Specimen Properly Aligned within a Testing Apparatus Suitable for Compressive Strength Testing

specimens. When perceptible variations occur, the purchaser may select as many samples as are necessary to determine the variation in compressive strength.

6.2 Compressive strength testing of specimens in more than two orientations with respect to splitting, including: rift (plane of easiest splitting), grain (plane of next easiest splitting), and head grain (plane of hardest splitting) can be desired for some stone types. Depending on the stone type and application, testing of additional orientations may be appropriate. An additional ten samples are necessary for testing each additional orientation in both wet and dry conditions (five for wet and five for dry). The required number of specimens shall be prepared with the load-bearing surface for each of these orientations properly labeled for testing.

NOTE 1—Refer to Guide C1799 for additional information on selecting, preparing, and conditioning test specimens.

7. Test Specimens

7.1 The test specimens may be cubes or right cylinders and shall be cut from the sample with saws or core drills. The diameter or lateral dimension (distance between opposite vertical surfaces) shall be not less than 2 in. [50 mm] dimensional to accommodate variations in the grain size or composition of the sample (Explanatory Note 1).

7.2 The ratio of height (the distance between the surfaces in contact with the testing apparatus) to the diameter or lateral dimension shall be between 0.9:1.0 and 1.1:1.0 (Explanatory Note 2).

7.3 The sides of the specimen shall be smooth and straight to within 0.02 in. [0.5 mm] over the full height of the specimen.

7.4 The two load bearing surfaces in contact with the testing apparatus shall have a fine abrasive finish, and the other surfaces shall have a fine sawn finish. They shall be finished by grinding to as nearly true and parallel planes as practicable (Explanatory Note 3). The surfaces in contact with the testing apparatus shall be ground or lapped to a flatness tolerance of plus or minus 0.005 in. [0.1 mm], and shall not depart from perpendicular to the longitudinal axis of the specimen by more than 0.25 deg. (Explanatory Note 4).

7.5 At least five specimens shall be prepared for each test condition. Final test conditions are determined by the project conditions and specified with the testing request. Typically, testing includes wet and dry conditions both perpendicular and parallel to the stone rift (plane of easiest splitting, typically consistent with the bedding plane orientation), requiring a minimum of 20 specimens. Fig. 2a and Fig. 2b illustrate the proper placement of test specimens within a testing apparatus for the two most common rift orientations.

7.6 The load-bearing surfaces and the direction of rift shall be marked on each specimen.

7.7 Use of capping materials or end surfacing treatments other than grinding shall not be permitted.

8. Conditioning

8.1 Before testing the specimens in a dry condition, dry them for at least 48 h at 140 ± 4°F [60 ± 2°C]. At the 46th, 47th, and 48th h, weigh the specimens to ensure that the weight is the same. If the weight continues to drop, continue to dry the specimens until there are 3 successive hourly readings with the same weight. After removing the specimens from the oven, cool them to room temperature in a desiccator before testing them.

8.2 Before testing the specimens in a wet condition, immerse them in water for at least 48 h at 72 ± 4°F [22 ± 2°C].

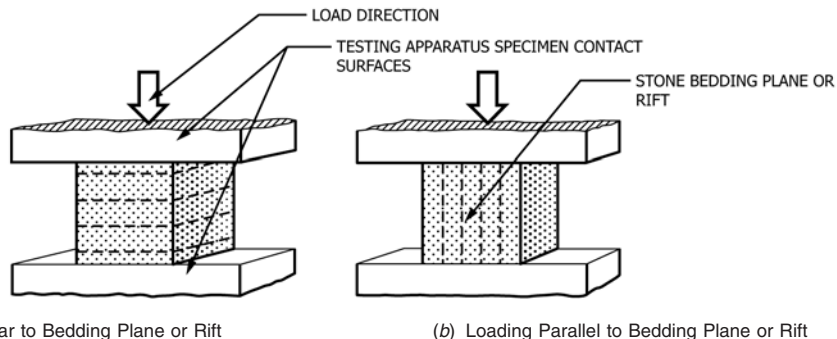

FIG. 2 Orientation of Specimen in a Testing Apparatus with Respect to Bedding Plane or Rift