



Designation: F2706 – 17

Standard Test Methods for Occipital-Cervical and Occipital-Cervical-Thoracic Spinal Implant Constructs in a Vertebroctomy Model¹

This standard is issued under the fixed designation F2706; the number immediately following the designation indicates the year of original adoption or, in the case of revision, the year of last revision. A number in parentheses indicates the year of last reapproval. A superscript epsilon (ϵ) indicates an editorial change since the last revision or reapproval.

1. Scope

1.1 These test methods cover the materials and methods for the static and fatigue testing of occipital-cervical and occipital-cervical-thoracic spinal implant assemblies in a vertebroctomy model. The test materials for most combinations of occipital-cervical and occipital-cervical-thoracic spinal implant components can be specific depending on the intended location and intended method of attachment.

1.2 These test methods are intended to provide a basis for the mechanical comparison among past, present, and future occipital-cervical and occipital-cervical-thoracic spinal implant assemblies. They allow comparison of occipital-cervical and occipital-cervical-thoracic spinal implant constructs with different methods of application to the spine. These test methods are not intended to define levels of performance, since sufficient knowledge is not available to predict the consequences of the use of a particular device.

1.3 These test methods set out guidelines for load types and methods of applying loads. Methods for three static load types and two fatigue tests for the comparative evaluation of occipital-cervical and occipital-cervical-thoracic spinal implant assemblies are defined.

1.4 These test methods establish guidelines for measuring displacements, determining the yield load, and evaluating the stiffness and strength of occipital-cervical or occipital-cervical-thoracic spinal implant assemblies.

1.5 It may not be possible to test some occipital-cervical and some occipital-cervical-thoracic spinal constructs in all test configurations.

1.6 The values stated in SI units are to be regarded as standard. No other units of measurement are included in this standard.

1.7 *This standard does not purport to address all of the safety concerns, if any, associated with its use. It is the*

responsibility of the user of this standard to establish appropriate safety and health practices and determine the applicability of regulatory limitations prior to use.

1.8 *This international standard was developed in accordance with internationally recognized principles on standardization established in the Decision on Principles for the Development of International Standards, Guides and Recommendations issued by the World Trade Organization Technical Barriers to Trade (TBT) Committee.*

2. Referenced Documents

2.1 *ASTM Standards:*²

- E4 Practices for Force Verification of Testing Machines
- E6 Terminology Relating to Methods of Mechanical Testing
- E739 Practice for Statistical Analysis of Linear or Linearized Stress-Life ($S-N$) and Strain-Life ($\epsilon-N$) Fatigue Data
- E1823 Terminology Relating to Fatigue and Fracture Testing
- F1582 Terminology Relating to Spinal Implants
- F1717 Test Methods for Spinal Implant Constructs in a Vertebroctomy Model
- F2077 Test Methods For Intervertebral Body Fusion Devices

3. Terminology

3.1 *Definitions*—For definitions of terms relating to these test methods, see Terminologies E6, F1582, and E1823.

3.2 *Definitions of Terms Specific to This Standard:*

3.2.1 *active length of the longitudinal element, n* —the straight line distance between the centers of rotation of the test blocks.

3.2.2 *block moment arm, n* —the perpendicular to the applied load between the insertion point of an anchor and the axis of the hinge pin.

3.2.3 *compressive or tensile bending stiffness (N/mm), n* —the compressive or tensile bending yield force divided by elastic displacement (see the initial slope of line BC in Fig. 1).

3.2.4 *compressive or tensile bending ultimate load (N), n* —the maximum compressive or tensile force in the $X-Z$ plane

¹ These test methods are under the jurisdiction of ASTM Committee F04 on Medical and Surgical Materials and Devices and are the direct responsibility of Subcommittee F04.25 on Spinal Devices.

Current edition approved March 1, 2017. Published April 2017. Originally approved in 2008. Last previous edition approved in 2014 as F2706 – 08 (2014). DOI: 10.1520/F2706-17.

² For referenced ASTM standards, visit the ASTM website, www.astm.org, or contact ASTM Customer Service at service@astm.org. For *Annual Book of ASTM Standards* volume information, refer to the standard's Document Summary page on the ASTM website.

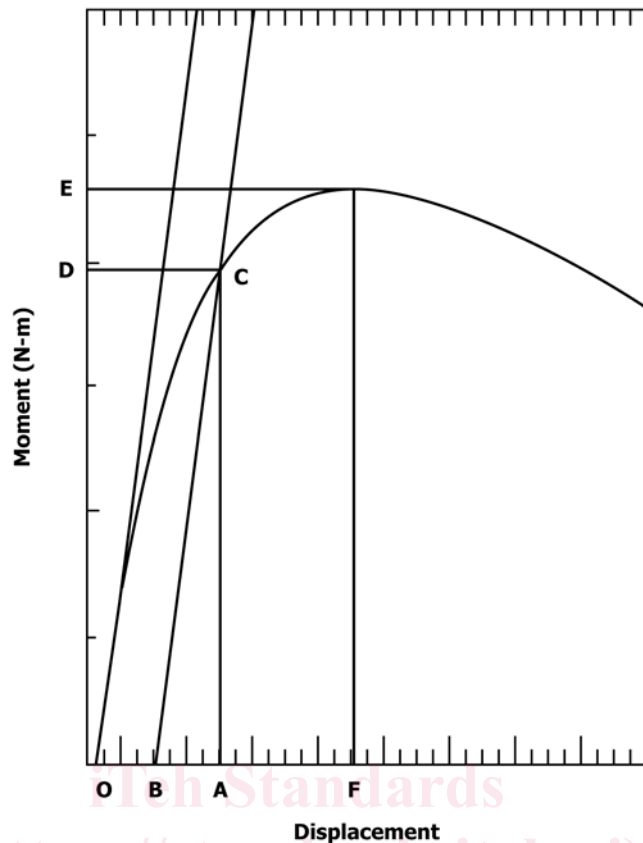

FIG. 1 Typical Load Displacement Curve or Torque Angulation Curve

applied to an occipital-cervical or occipital-cervical-thoracic spinal implant assembly (see the force at Point E in Fig. 1). The ultimate load should be a function of the device and not of the load cell or testing machine.

3.2.5 *compressive or tensile bending yield load (N), n*—the compressive or tensile bending force in the X-Z plane necessary to produce a permanent deformation equal to 0.020 times the active length of the longitudinal element (see the force at Point D in Fig. 1).

3.2.6 *coordinate system/axes, n*—three orthogonal axes are defined in Figs. 2 and 3. The anterior-posterior axis is X with positive being anterior. The medial-lateral axis is Y with left being positive when viewed posteriorly. The superior-inferior axis is Z with superior being positive.

3.2.7 *displacement at 2 % offset yield (mm), n*—the displacement of a construct measured via the actuator that produces a permanent deformation equal to 0.020 times the active length of the longitudinal element (distance OA in Fig. 1).

3.2.8 *elastic angular displacement (degrees), n*—the angular displacement at 2 % offset yield (see Point A in Fig. 1) minus the 2 % offset angular displacement (see Point B in Fig. 1) (that is, the distance between Point A and Point B in Fig. 1).

3.2.9 *elastic displacement (mm), n*—the displacement at 2 % offset yield (see Point A in Fig. 1) minus the 2 % offset displacement (see Point B in Fig. 1). (The distance between Point A and Point B in Fig. 1).

3.2.10 *failure, n*—permanent deformation resulting from fracture, plastic deformation, or loosening beyond the ultimate displacement or loosening that renders the occipital-cervical or occipital-cervical-thoracic spinal implant assembly ineffective or unable to adequately resist load.

3.2.11 *fatigue life, n*—the number of loading cycles, N, of a specified character that the occipital-cervical or occipital-cervical-thoracic spinal implant assembly sustains before failure of a specified nature occurs (see Terminology E1823).

3.2.12 *hinge pin, n*—the cylindrical rod connecting a test block to a side support. The superior and inferior aspects of the test construct are each secured with a single 9.6-mm diameter pin.

3.2.13 *insertion point of an anchor, n*—the location where the anchor is attached to the test block. The insertion points shown in Figs. 4-7 are to be adhered to, if possible. In situations where the design of the occipital-cervical or occipital-cervical-thoracic spinal implant assembly or the manufacturer’s surgical instructions for installation dictate otherwise, the attachment points may deviate from these dimensions.

3.2.14 *intended method of application, n*—occipital-cervical and occipital-cervical-thoracic spinal implant assemblies contain different types of anchors. Each type of anchor has an intended method of application to the spine.

3.2.15 *intended occipital-cervical spinal location, n*—the anatomic region of the spine intended for the application of the

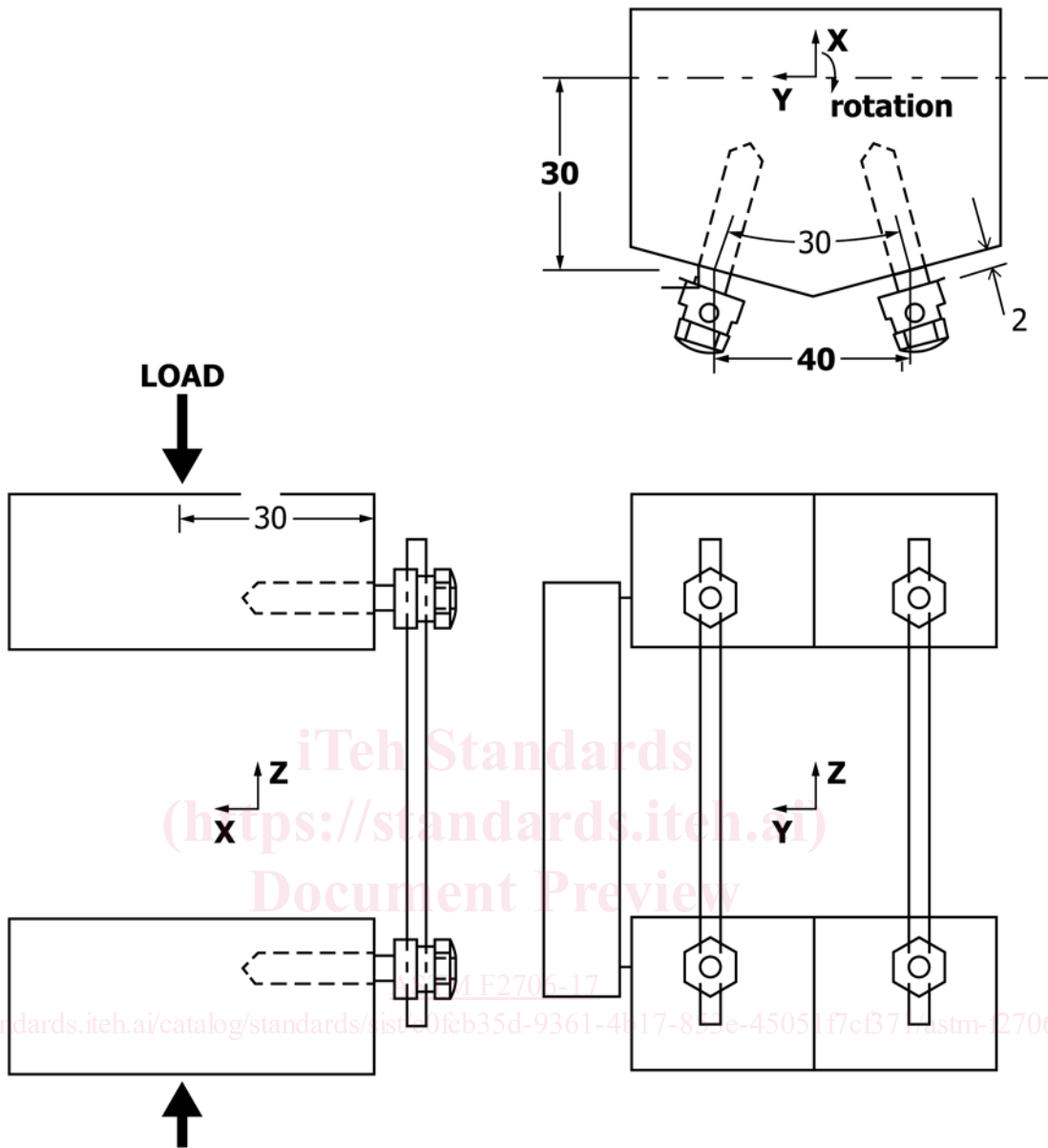

FIG. 2 A Standard Bilateral Construct Containing Screw, Rod and Screw

occipital-cervical spinal implant assembly. Spinal implant assemblies are developed for specific spinal locations such as the posterior occipital-cervical spine.

3.2.16 *intended occipital-cervical-thoracic spinal location, n*—the anatomic region of the spine intended for the application of the occipital-cervical-thoracic spinal implant assembly. Spinal implant assemblies are developed for specific spinal locations such as the posterior occipital-cervical-thoracic spine.

3.2.17 *longitudinal axis offset (mm), n*—distance in the X direction between the centerline of the longitudinal element and the insertion point of the anchors on the polyacetal test block.

3.2.18 *longitudinal direction, n*—the initial spatial orientation parallel to the longitudinal element of the occipital-cervical or occipital-cervical-thoracic spinal implant assembly.

The longitudinal direction is generally in the superior-inferior direction and therefore, generally parallel to the Z-axis.

3.2.19 *maximum runout load, n*—the maximum load that can be applied to an occipital-cervical or occipital-cervical-thoracic spinal implant assembly where all of the tested constructs have withstood 5 000 000 cycles without a failure.

3.2.20 *occipital-cervical spinal implant assembly, n*—a complete occipital-cervical spinal implant configuration as intended for surgical use. An occipital-cervical spinal implant assembly will contain anchors, interconnections, and longitudinal elements and may contain transverse elements (see Figs. 2-7).

3.2.21 *occipital-cervical spinal implant construct, n*—a complete occipital-cervical spinal implant assembly attached to the appropriate test blocks.

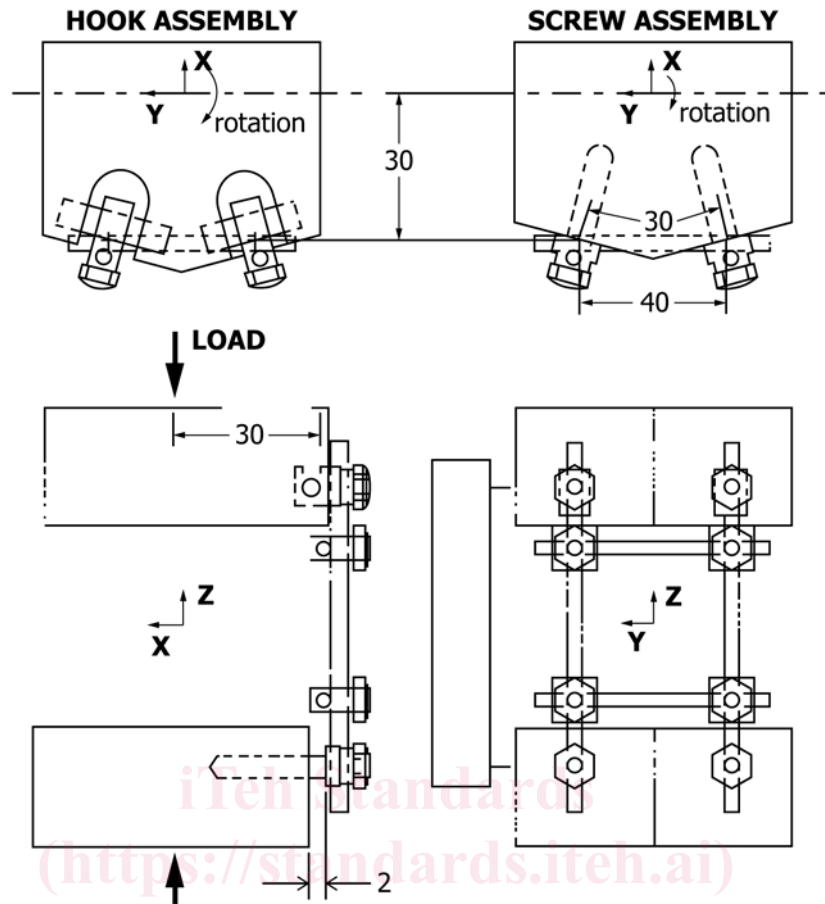

FIG. 3 A Bilateral Hook, Rod, Screw, and Transverse Element Construct

3.2.22 *occipital-cervical-thoracic spinal implant assembly, n*—a complete occipital-cervical-thoracic spinal implant configuration as intended for surgical use. An occipital-cervical-thoracic spinal implant assembly will contain anchors, interconnections, and longitudinal elements and may contain transverse elements (see Figs. 2-7).

3.2.23 *occipital-cervical-thoracic spinal implant construct, n*—a complete occipital-cervical-thoracic spinal implant assembly attached to the appropriate test blocks.

3.2.24 *offset angular displacement at 2 % offset, n*—a permanent angular displacement in the X-Y plane measured via the actuator equal to 0.020 times the torsional aspect ratio (for example: 1.95° for $1.70 \times 0.02 \times 180^\circ/\pi$) (see Point B in Fig. 1).

3.2.25 *offset displacement (mm), n*—a permanent deformation measured via the actuator equal to 0.020 times the active length of the longitudinal element (for example: 1.52 mm for a 76 mm active length of the longitudinal element) (see Point B in Fig. 1).

3.2.26 *permanent deformation, n*—the displacement (mm) or angular displacement (degree) of the occipital-cervical or occipital-cervical-thoracic spinal implant construct relative to

the initial unloaded condition as measured via the actuator after the applied load, moment, or torque has been removed.

3.2.27 *test block, n*—the component of the test apparatus for mounting the occipital-cervical or occipital-cervical-thoracic spinal implant assembly. A specific design of test block is required for each intended spinal location and intended method of application. Figs. 5-7 describe the recommended designs for the test blocks; however, alternate designs can be used as long as equivalent performance is demonstrated.

3.2.28 *test block load point, n*—the location on the test block at which the resultant load is transmitted from the test apparatus.

3.2.29 *tightening torque, n*—the specified torque that is applied to the various threaded fasteners of the occipital-cervical or occipital-cervical-thoracic spinal implant assembly.

3.2.30 *torsional aspect ratio, n*—the active length of the longitudinal element divided by the distance from the center of rotation to the insertion point of an anchor on the cervical block (for example: in Fig. 2, 1.70 for a 76-mm active length, $X = 40$ mm and $Y = 40/2$ mm).

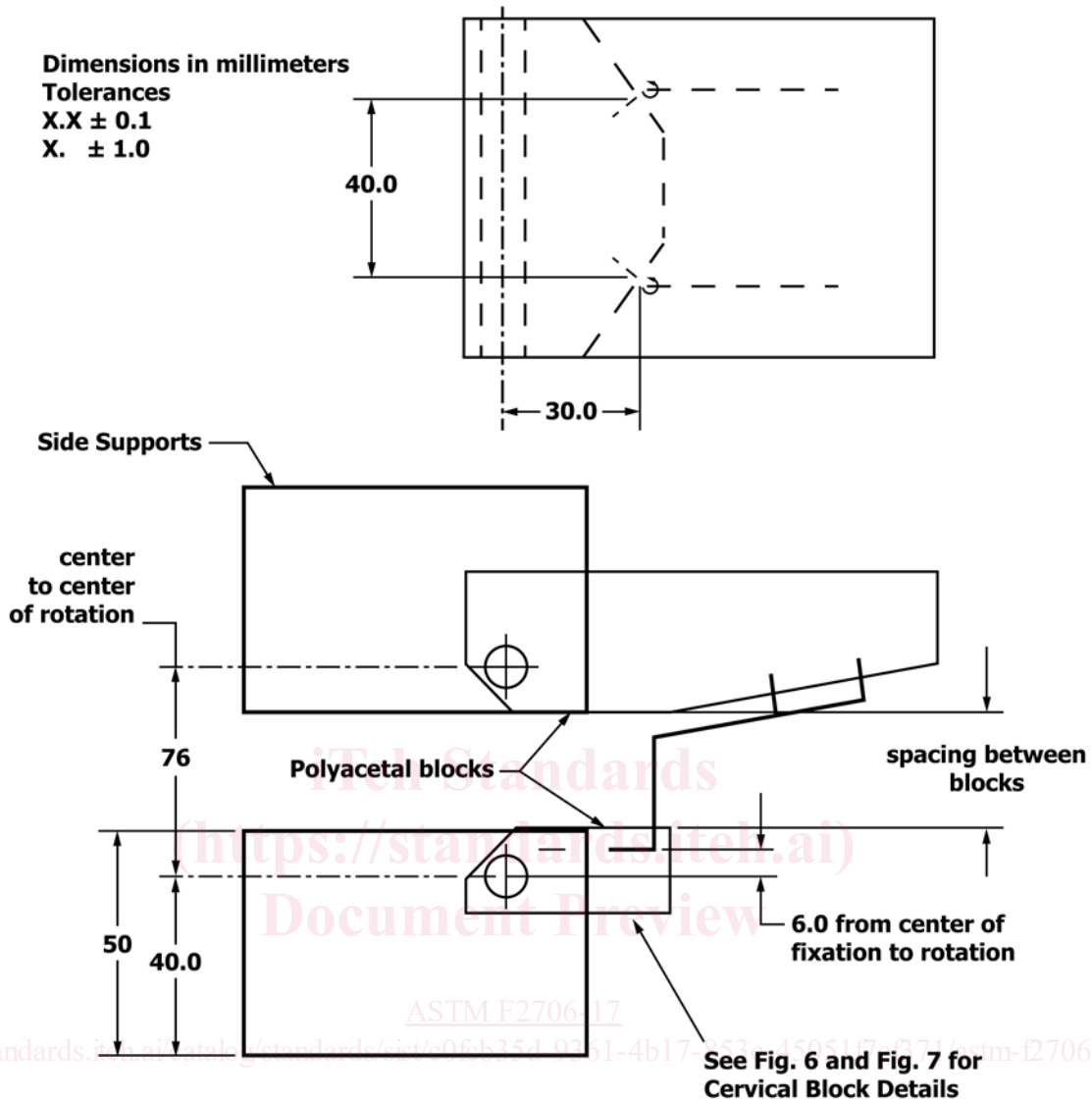

FIG. 4 Occipital-Cervical Bilateral Construct Test Setup for Occipital Screws or Bolts

$$A = \frac{L}{D} = \frac{L}{(x^2 + y^2)^{1/2}} \quad (1)$$

where:

- L = active length of longitudinal element,
- D = distance to insertion point,
- x = x distance to insertion point, and
- y = y distance to insertion point.

3.2.31 *torsional stiffness (N-m/degree)*, n —the yield torque (N-m) divided by elastic angular displacement (degrees) (the initial slope of line BC in Fig. 1).

3.2.32 *torsional ultimate load (N-m)*, n —the maximum torque in the X-Y plane applied to an occipital-cervical or occipital-cervical-thoracic spinal implant assembly (the torque at Point E in Fig. 1). The ultimate torque should be a function of the device and not of the load cell or testing machine.

3.2.33 *ultimate displacement (mm)*, n —the displacement associated with the ultimate load, ultimate bending load or ultimate torque (the displacement at Point F in Fig. 1).

3.2.34 *yield displacement (distance OA—Fig. 6)*, n —the displacement (mm) or angular displacement (deg) when an assembly has a permanent deformation equal to the offset displacement or the offset angular displacement.

3.2.35 *yield torque (N-m)*, n —the torque in the X-Y plane required to produce a permanent displacement of 0.020 times the torsional aspect ratio (the torque at Point D in Fig. 1).

3.2.36 *zero displacement intercept (mm)*, n —the intersection of the straight line section of the load-displacement curve and the zero load axis (the zero displacement reference Point 0 in Fig. 1).

4. Summary of Test Methods

4.1 Similar test methods are proposed for the mechanical evaluation of all occipital-cervical and occipital-cervical-thoracic spinal implant assemblies (see Fig. 4).

4.2 A vertebrectomy model is used for the evaluation of both occipital-cervical and occipital-cervical-thoracic systems.

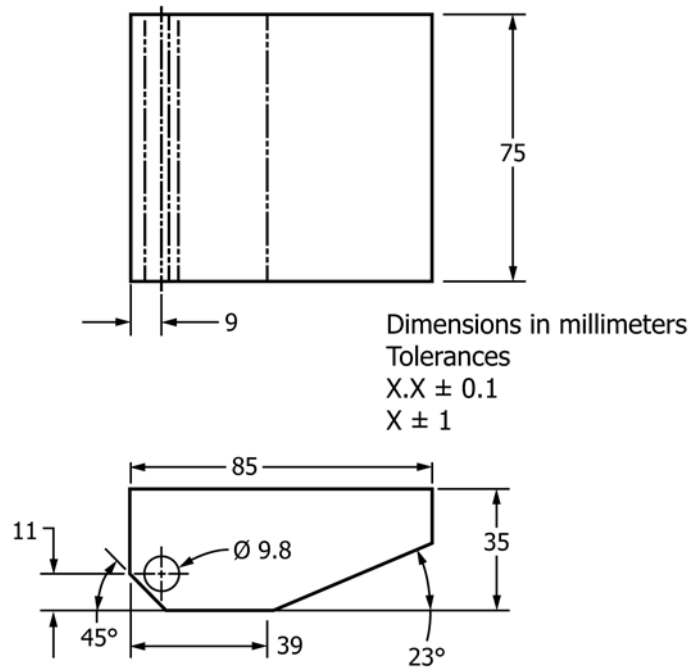

FIG. 5 Occipital Bilateral Polyacetal Block for Occipital Screws or Bolts

The spinal hardware is attached at the superior and inferior aspects to polyacetal homopolymer (polyacetal) test blocks separated by a large gap. The polyacetal homopolymer used to manufacture the test blocks should have a tensile breaking strength no less than 61 MPa. The use of polyacetal test blocks (see Figs. 5-8) eliminates the effects of the variability of bone geometry and material properties associated with cadaveric testing. Alternate designs of test blocks may be used as long as equivalent performance is demonstrated.

4.3 Three static mechanical tests and two dynamic tests will evaluate the occipital-cervical or occipital-cervical-thoracic spinal implant assemblies. The three static mechanical tests are compression bending, tensile bending, and torsion. The dynamic tests are compression bending fatigue and torsion fatigue.

4.4 A specific clinical indication generally requires a specific occipital-cervical or occipital-cervical-thoracic spinal implant assembly. Occipital-cervical and occipital-cervical-thoracic spinal implant assemblies will be evaluated with test configurations that simulate the clinical requirements for the intended spinal location. The intended spinal location is the posterior surface of the occipital-cervical or occipital-cervical-thoracic spine (see Fig. 4). The block moment arm for a test configuration depends on the intended spinal location. The block moment arm of the occipital-cervical or occipital-cervical-thoracic spine configuration (see Fig. 4) varies depending on the occipital attachment components, but should be no less than the block moment arm specified in the cervical spine configuration. The cervical spine configuration (see Figs. 6 and 7) specifies the block moment arm.

4.5 The intended method of application of the occipital-cervical or occipital-cervical-thoracic spinal implant assembly may vary for specific anatomic regions and clinical indications.

Occipital-cervical and occipital-cervical-thoracic spinal implant assemblies contain different types of anchors. Each type of anchor has an intended method of application to the spine. For example, one assembly may include screws and rods (see Fig. 2), while another assembly may contain screws, hooks, rods, and transverse elements (see Fig. 3). The block moment arm of a test configuration will be independent of the intended method of application of a spinal implant assembly, thereby allowing the user to compare devices for a given load. However, it should be noted that the same load on different implant assemblies will result in different loading on the implants as a function of implant design. The user should take this into account when evaluating the performance of a device.

5. Significance and Use

5.1 Occipital-cervical and occipital-cervical-thoracic spinal implants are generally composed of several components which, when connected together, form either an occipital-cervical spinal implant assembly or an occipital-cervical-thoracic spinal implant assembly. Occipital-cervical and occipital-cervical-thoracic spinal implant assemblies are designed to provide some stability to the spine during the process of arthrodesis. These test methods outline standard materials and methods for the evaluation of different spinal implant assemblies to facilitate comparisons between different designs.

5.2 These test methods are used to quantify the static and dynamic mechanical characteristics of different designs of occipital-cervical and occipital-cervical-thoracic spinal implant assemblies. The mechanical tests are conducted *in vitro* using simplified load schemes and do not attempt to mimic the complex loads of the occipital-cervical and occipital-cervical-thoracic spine.