



Standard Test Method for Resistance to Wildfire Penetration of Eaves, Soffits and Other Projections¹

This standard is issued under the fixed designation E2957; the number immediately following the designation indicates the year of original adoption or, in the case of revision, the year of last revision. A number in parentheses indicates the year of last reapproval. A superscript epsilon (ϵ) indicates an editorial change since the last revision or reapproval.

1. Scope

1.1 This fire-test-response standard prescribes a method for qualitatively assessing the resistance to fire penetration of eave overhangs and other projections, such as the soffits of roof eaves and cantilevered floor projections, when exposed to direct flame impingement from a simulated external wildfire exposure, such as encountered in a “Wildland Urban Interface” scenario. This test method provides data suitable for comparing the relative performance of materials, which are used as the exposed underside surfaces of eave overhangs and other projections.

1.2 This test method measures the ability of eave overhangs and other projections to resist fire penetration from the exterior into the wall cavity or unexposed side of the test specimen under the conditions of exposure.

1.3 This test method is applicable to eave overhangs and other projections such as the soffits of roof eaves and cantilevered floor projections intended for use with either combustible or noncombustible building envelopes.

1.4 Limitations of the test method are listed in Section 5.

1.5 The values stated in metric units are to be regarded as the standard. Values in parentheses are for information only.

1.6 *This standard does not purport to address all of the safety concerns, if any, associated with its use. It is the responsibility of the user of this standard to establish appropriate safety and health practices and determine the applicability of regulatory limitations prior to use.*

1.7 *This standard is used to measure and describe the response of materials, products, or assemblies to heat and flame under controlled laboratory conditions, but does not by itself incorporate all factors required for fire hazard or fire risk assessment of the materials, products or assemblies under actual fire conditions.*

1.8 *Fire testing is inherently hazardous. Adequate safeguards for personnel and property shall be employed in conducting these tests.*

1.9 *The text of this standard references notes and footnotes which provide explanatory material. These notes and footnotes (including those in tables and figures) shall not be considered as requirements of the standard.*

1.10 *This international standard was developed in accordance with internationally recognized principles on standardization established in the Decision on Principles for the Development of International Standards, Guides and Recommendations issued by the World Trade Organization Technical Barriers to Trade (TBT) Committee.*

2. Referenced Documents

2.1 *ASTM Standards:*²

C1396 Specification for Gypsum Board

D2898 Practice for Accelerated Weathering of Fire-Retardant-Treated Wood for Fire Testing

D4442 Test Methods for Direct Moisture Content Measurement of Wood and Wood-Based Materials

D4444 Test Method for Laboratory Standardization and Calibration of Hand-Held Moisture Meters

D6662 Specification for Polyolefin-Based Plastic Lumber Decking Boards

D7032 Specification for Establishing Performance Ratings for Wood-Plastic Composite and Plastic Lumber Deck Boards, Stair Treads, Guards, and Handrails

E176 Terminology of Fire Standards

¹ This test method is under the jurisdiction of ASTM Committee E05 on Fire Standards and is the direct responsibility of Subcommittee E05.14 on External Fire Exposures. Current edition approved July 1, 2015; May 1, 2017. Published August 2015; May 2017. Originally approved in 2015. Last previous edition approved in 2015 as E2957-15. DOI: 10.1520/E2957-15.10.1520/E2957-17.

² For referenced ASTM standards, visit the ASTM website, www.astm.org, or contact ASTM Customer Service at service@astm.org. For *Annual Book of ASTM Standards* volume information, refer to the standard's Document Summary page on the ASTM website.

E631 Terminology of Building Constructions

E2707 Test Method for Determining Fire Penetration of Exterior Wall Assemblies Using a Direct Flame Impingement Exposure

E2912 Test Method for Fire Test of Non-Mechanical Fire Dampers Used in Vented Construction

E2886/E2886M Test Method for Evaluating the Ability of Exterior Vents to Resist the Entry of Embers and Direct Flame Impingement

2.2 *Other Standards:*

ISO 13943 Fire Safety—Vocabulary³

NFPA 286 Standard Methods of Fire Tests for Evaluating Contribution of Wall and Ceiling Interior Finish to Room Fire Growth⁴

3. Terminology

3.1 *Definitions*—For definitions of terms used in this standard, see Terminology **E176**, **E631** and ISO 13943. In case of conflict between **E176** and **E631** or ISO 13943, the definitions given in Terminology **E176** shall prevail. In case of conflict between **E631** and ISO 13943, the definitions given in Terminology **E631** shall prevail.

3.2 *Definitions of Terms Specific to This Standard:*

3.2.1 *building envelope, n*—the boundary or barrier separating different environmental conditions within a building and from the outside environment.

3.2.2 *eave, n*—a projecting edge of a roof that extends beyond the building envelope.

3.2.3 *glow, n*—visible light emitted by a solid undergoing combustion.

3.2.4 *holding fixture, n*—apparatus designed to hold the test specimen and a wall assembly, described in **7.3**.

3.2.5 *projection, n*—an exterior outcrop of the building, such as a cantilevered room, that protrudes from or overhangs the building envelope.

³ Available from International Organization for Standardization (ISO), 1, ch. de la Voie-Creuse, CP 56, CH-1211 Geneva 20, Switzerland, <http://www.iso.org>.

⁴ Available from National Fire Protection Association (NFPA), 1 Batterymarch Park, Quincy, MA 02169-7471, <http://www.nfpa.org>.

3.2.5.1 *Discussion*—

Examples include, but are not limited to, eaves, soffits, enclosed cantilevered balconies, and enclosed cantilevered room bump-outs.

3.2.6 *soffit, n*—the enclosed underside of any exterior overhanging section of a roof eave.

3.2.7 *sustained flaming, n*—flame on or over the surface of a test specimen that lasts longer than a period of 4 s.

3.2.8 *wall assembly, n*—framed vertical section simulating an exterior wall below an eave overhang or projection used in the evaluation of test specimen.

3.2.8.1 *Discussion*—

Paragraph **7.2** describes the wall assembly used in this test method.

4. Summary of Test Method

4.1 This test method provides for the direct flame exposure of eave overhang and other projections.

4.2 This test method employs a gas burner to produce a diffusion flame in contact with the test specimen.

4.3 The flame source is centered left to right and below the test specimen.

4.4 The gas burner produces a prescribed net rate of heat output during the flame exposure period, after which the flame exposure is terminated.

4.5 The test method monitors the fire characteristics and the ability of the test specimen to resist fire penetration during the flame exposure period and a subsequent observation period.

4.6 Observations are made for the appearance of sustained flaming and glow on the unexposed side during the 10-min flame exposure period and a subsequent 30-min observation period.

5. Significance and Use

5.1 The test method described herein monitors the fire characteristics and the ability of eave overhangs and other projections to resist exterior fire penetration from underneath under the specified fire exposure conditions.

5.2 Representative joints and other characteristics of the eave overhang or projection shall be included in the test specimen when these details are representative of the end-use construction.

5.3 The test method does not apply to vents or perforated materials used to enclose or cap eaves, soffits, and other projections.

NOTE 1—Test Methods E2912 and E2886/E2886M are methods used to test vents or perforated materials to resist direct flame impingement and flame penetration into the building.

5.4 The test method is devised for eave overhangs and other projections independent of the materials covering the building envelope.

NOTE 2—Heat contribution from burning materials covering the building envelope beyond the prescribed fire exposure is not considered in this test method.

5.5 The test method does not necessarily represent the expected performance of eave overhang and projections under all actual fire conditions, but it does provide a basis for comparing eave overhang and projections materials when subjected to the test procedure described herein.

5.6 In this procedure, the test specimen is subjected to specific laboratory fire test conditions. If different test conditions are substituted or the anticipated end-use conditions are changed, it is not known whether it is possible by use of this test to predict changes in the performance characteristics measured. Therefore, the results are strictly valid only for the fire test conditions and construction tested.

5.7 The test method does not provide any basis for determining the fire resistance characteristics of eave overhangs or projections when exposed to a fire originating in the building.

5.8 The test method does not address interior or exterior flame spread.

6. Safety Precautions

6.1 The test procedure involves high temperatures and combustion processes. Therefore, the potential exists for burns, ignition of extraneous objects or clothing, and for inhalation of combustion products.

7. Apparatus

7.1 Unless otherwise noted, dimensions in the following descriptions shall be followed with a tolerance of ± 13 mm (0.5 in.).

7.2 *Wall Assembly*—Framed assembly made up of standard 38 by 89 by 2440 mm (2 by 4 in. by 8 ft) standard wood wall studs (metal studs optional) at 406 mm (16 in.) o.c. overlaid with 16 mm ($\frac{5}{8}$ in.) Type “X” gypsum board complying with Specification C1396, or a noncombustible board material of nominal thickness of 12 mm ($\frac{1}{2}$ in.) or greater.

7.2.1 The wall assembly dimensions shall be 1220 mm (4 ft) wide and 2440 mm (8 ft) high.

7.3 *Holding Fixture*—The assembly shown in Figs. 1 and 2 is designed to permit rapid installation and removal of the test specimen and the wall assembly, and to prevent edge penetration of fire at the margins of the wall assembly. The holding fixture includes a sturdy frame assembly to mount the test specimen and the wall assembly. The holding fixture permits a prefabricated wall assembly with an attached test specimen to be inserted from the rear and to seal in such a way that protects the wall assembly edges from fire. Side shields are situated near the vertical edges of the holding fixture and extend from the holding fixture’s base to within 305 mm (12 in.) of the top of the wall assembly as shown in Figs. 1 and 2 to aid in minimizing extraneous drafts to the surface of the test specimen.

7.3.1 The side shields shall consist of nominal 16 mm ($\frac{5}{8}$ in.) Type “X” gypsum board complying with Specification C1396 or a noncombustible board material of 12 mm ($\frac{1}{2}$ in.) nominal thickness or greater mounted on a sturdy frame.

7.3.2 The side shield dimensions shall be 609 mm (28 in.) wide and 2134 mm (84 in.) high.

NOTE 3—The holding fixture used in this test method is the same as the Wall Assembly Holding Fixture described in Paragraph 7.2, Test Method E2707 except the simulated noncombustible soffit has been replaced with the test specimen under investigation.

8. Test Room

8.1 The ambient temperature in the test room shall be above 15 °C (60 °F) and the relative humidity shall be less than 75 %. The test room shall be draft-protected and equipped with an exhaust hood system for removal of products of combustion during testing.

8.2 Air velocities in the vicinity of the ignition source burner shall not exceed 0.5 m/s (1.64 ft/s) measured at a horizontal distance of 0.5 m (20 in.) from the edge of the wall assembly.

8.3 Air supply shall not be limited during the test.

9. Ignition Source and Calibration

9.1 *Ignition Source Burner:*

9.1.1 The ignition source shall be a gas diffusion burner with a porous top surface of a refractory material.

9.1.1.1 The gas diffusion burner shall have a nominal surface area 305 by 305 mm (12 by 12 in.), as shown in Fig. 3.

9.1.1.2 The gas diffusion burner shall be supported for a nominal height of 152 mm (6 in.) making the total height 305 ± 6 mm (12 ± 0.25 in.).

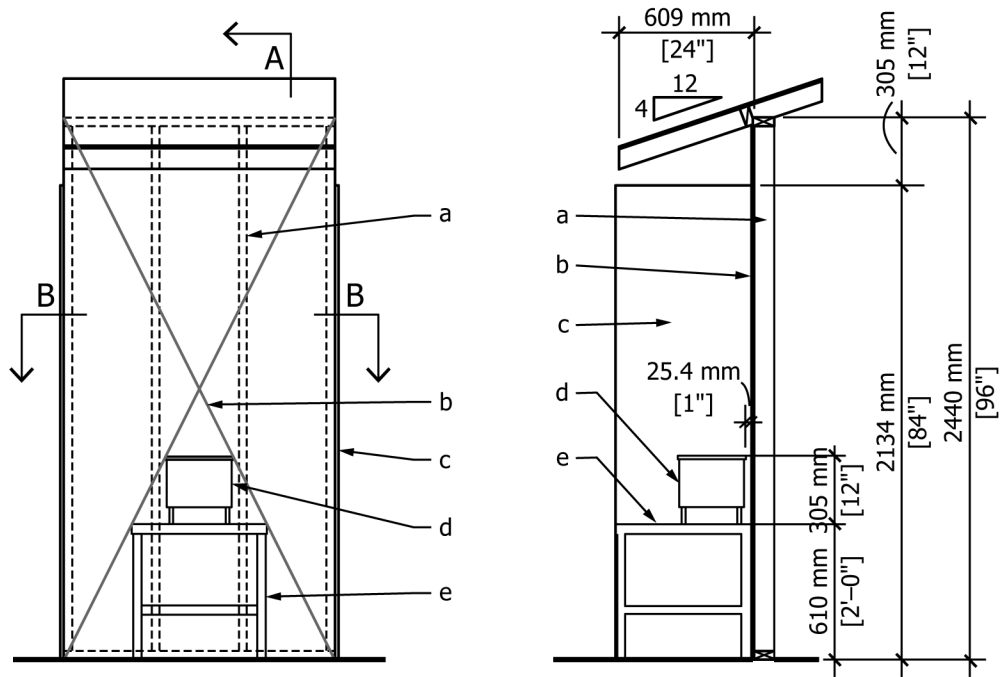

**SECTION A
EAVE PLACEMENT**

SECTION A-A

- a. Wood studs 38 mm × 89 mm [1 1/2" × 3 1/2"] @ 406 mm [16"] o.c. (metal studs optional)
- b. 16 mm [5/8"] type "X" gypsum board (optional 12.5 mm [1/2"]) 1220 mm × 2440 mm [48" × 96"], fastened to wall studs w/ #8 × 41.28 mm [1 5/8"] drywall screws @ 203 mm [8"] o.c. all edges and field
- c. 16 mm [5/8"] type "X" gypsum board (optional 12.5 mm [1/2"]) 609 mm × 2134 mm [28" × 84"], clamped to frame
- d. 305 mm × 305 mm [12" × 12"] gas diffusion burner
- e. Metal stand

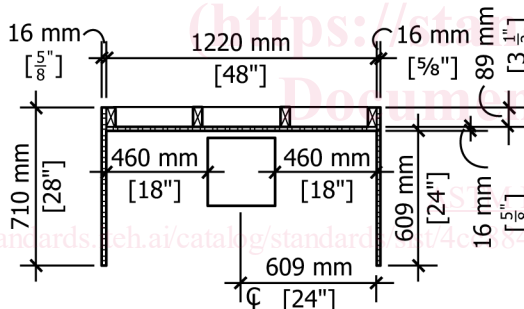

SECTION B-B

FIG. 1 Holding Fixture Loaded With Eave Test Specimen and Wall Assembly

NOTE 4—The burner used for testing in this standard is the same as described in Section 4.1, NFPA 286.

9.1.2 The refractory material specified in 9.1.1 shall be a minimum 102 mm (4 in.) layer of white Ottawa sand used to provide the horizontal surface through which the gas is supplied.

9.2 Burner Position:

9.2.1 The gas diffusion burner enclosure shall be positioned so that it is centered relative to the width of the wall assembly.

9.2.2 The gas diffusion burner shall be located 25 ± 6 mm (1 ± 0.25 in.) from the wall assembly.

9.2.3 The distance from the base of the holding fixture in Figs. 1 and 2 to the top surface of the gas diffusion burner shall be 915 ± 6 mm (36 ± 0.25 in.). To obtain the required distance from the base of the holding fixture in Figs. 1 and 2 to the top surface of the gas diffusion burner, the nominal 305 mm (12 in.) tall burner shall be placed on top of a nominal 610 mm (24 in.) tall metal stand with a nominal top surface area of 610 by 610 mm (24 by 24 in.). The metal stand is shown in Fig. 4.

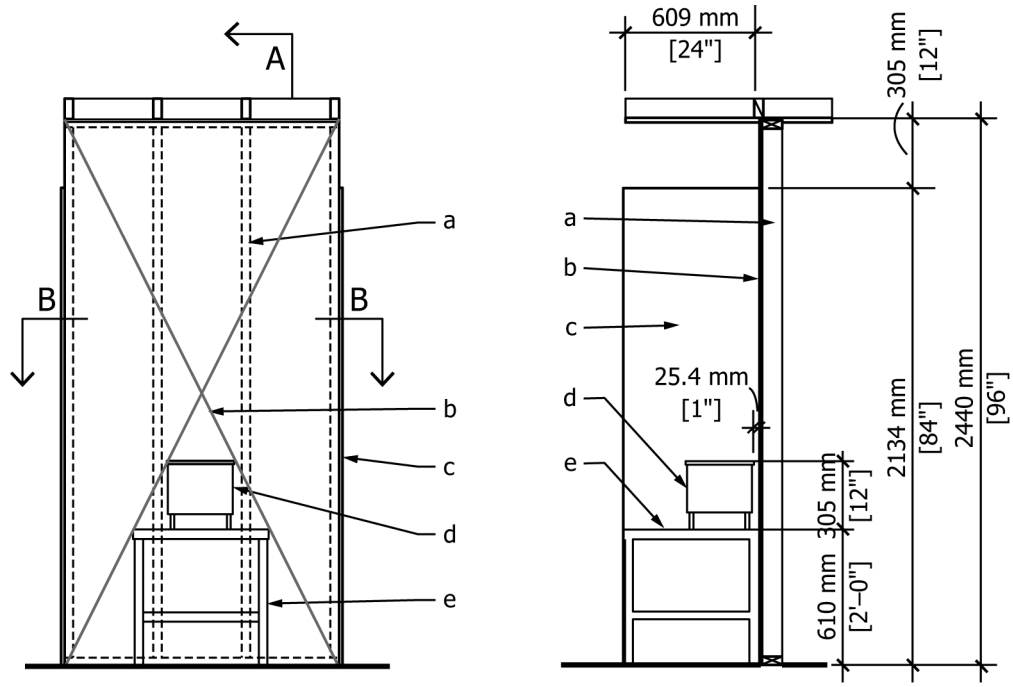

**SECTION A
SOFFIT PLACEMENT**

SECTION A-A

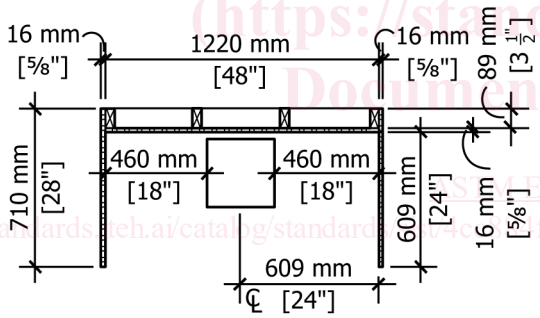

SECTION B-B

- a. Wood studs 38 mm × 89 mm [1 1/2" × 3 1/2"] @ 406 mm [16"] o.c. (metal studs optional)
- b. 16 mm [5/8"] type "X" gypsum board (optional 12.5 mm [1/2"]) 1220 mm × 2440 mm [48" × 96"], fastened to wall studs w/ #8 × 41.28 mm [1 5/8"] drywall screws @ 203 mm [8"] o.c. all edges and field
- c. 16 mm [5/8"] type "X" gypsum board (optional 12.5 mm [1/2"]) 609 mm × 2134 mm [28" × 84"], clamped to frame
- d. 305 mm × 305 mm [12" × 12"] gas diffusion burner
- e. Metal stand

FIG. 2 Holding Fixture Loaded With Projection Test Specimen and Wall Assembly

- 9.3 The gas diffusion burner shall be supplied with minimum 99 % pure propane (often described by suppliers as CP or "chemically pure" grade) having a nominal heating value of 93.0 MJ/m³ [22.2 kilocalories (thermochemical) per cubic meter or 2500 Btu (thermochemical) per cubic foot].
- 9.4 The propane shall be supplied to the gas diffusion burner through a metered control system.
- 9.5 The propane supply to the gas diffusion burner shall produce a net heat output of 300 ± 15 kW (17,060 ± 853 BTU/min).
- 9.6 The gas diffusion burner shall be ignited by a pilot burner or a remotely controlled spark igniter.
- 9.7 Gas diffusion burner controls shall be provided for automatic gas supply shut-off if flameout occurs.
- 9.8 *Gas Diffusion Burner Calibration:*

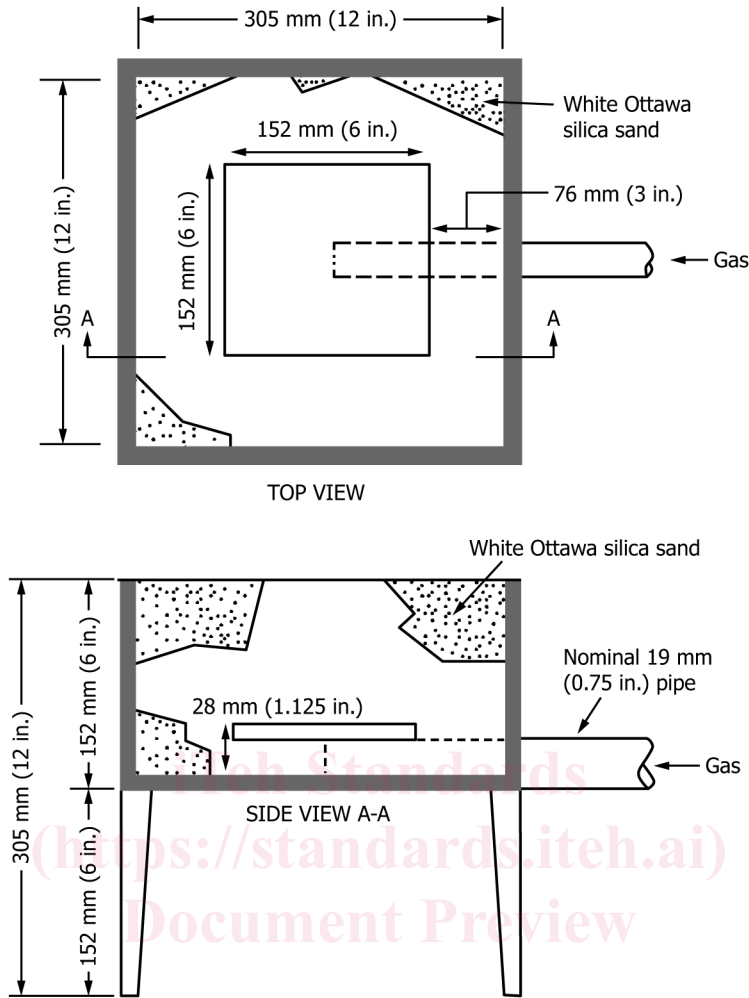

FIG. 3 Gas Diffusion Burner for Test

<https://standards.iteh.ai/catalog/standards/sist/4cc884f3-5d39-46ec-99a5-0754509d0113/astm-e2957-17>

9.8.1 The gas supply to the gas diffusion burner shall be the same as used for testing. The gas shall be metered and kept constant throughout the calibration test.

9.8.2 Place the gas diffusion burner in the configuration to be used for testing and obtain the heat release rate value prescribed in 9.5.

9.8.3 Take measurements at least once every 6 s and start 1 min prior to ignition of the gas diffusion burner. Determine the average heat output over a period of at least 1 min by the oxygen consumption method, or calculate the heat output from the gas mass flow and the net heat of combustion.

9.9 Frequency of Calibration:

9.9.1 Calibrate the gas diffusion burner for heat output prior to each day's use.

9.9.2 Any indication of off-limit condition such as unusual flame appearance or flame contour, excess turbulence, or unusual noise shall be cause for calibration prior to further use.

10. Preparation of Test Specimens

10.1 Unless otherwise noted, dimensions in the following descriptions, shall be followed with a tolerance of ± 13 mm (0.5 in.).

10.2 Construction of Test Specimen:

10.2.1 The test specimen shall be 1220 mm (4 ft) wide. When applicable, normal roof framing, joints, and other typical features present in the end-use construction shall be present in the test specimen.

10.2.2 The test specimen shall extend out from the wall assembly a distance of 610 mm (24 in.) and be finished in a manner appropriate for exterior exposure as per accepted construction practices.

10.2.2.1 Testing of test specimens with an extension from the wall other than 610 mm (24 in.) is permitted. However, applicability of the results is limited to the extension tested or less, and shall be noted in the report.

10.2.3 The solid left and right vertical sides of the test specimen shall be finished with a noncombustible material to prevent unintended direct flame impingement of internal components.