

INTERNATIONAL STANDARD

ISO
4017

Second edition
1988-06-01



INTERNATIONAL ORGANIZATION FOR STANDARDIZATION
ORGANISATION INTERNATIONALE DE NORMALISATION
МЕЖДУНАРОДНАЯ ОРГАНИЗАЦИЯ ПО СТАНДАРТИЗАЦИИ

Hexagon head screws — Product grades A and B

Vis à tête hexagonale — Grades A et B

iTeh STANDARD PREVIEW
(standards.iteh.ai)

ISO 4017:1988

<https://standards.iteh.ai/catalog/standards/sist/f4c89c88-183b-4f10-b1be-357e48e0eccf/iso-4017-1988>

Reference number
ISO 4017: 1988 (E)

Foreword

ISO (the International Organization for Standardization) is a worldwide federation of national standards bodies (ISO member bodies). The work of preparing International Standards is normally carried out through ISO technical committees. Each member body interested in a subject for which a technical committee has been established has the right to be represented on that committee. International organizations, governmental and non-governmental, in liaison with ISO, also take part in the work.

Draft International Standards adopted by the technical committees are circulated to the member bodies for approval before their acceptance as International Standards by the ISO Council. They are approved in accordance with ISO procedures requiring at least 75 % approval by the member bodies voting.

International Standard ISO 4017 was prepared by Technical Committee ISO/TC 2, *Fasteners*.

This second edition cancels and replaces the first edition (ISO 4017:1979), to which the following major alterations have been made:

- a) the range of threads has been extended to be M1,6 to M64;
- b) the range of nominal lengths has been extended up to 200 mm;
- c) non-preferred threads have been entered;
- d) in addition to property class 8.8, property classes 5.6 and 10.9 have been entered;
- e) for stainless steel screws above M20 up to M39, property class A2-50 has been specified.

Users should note that all International Standards undergo revision from time to time and that any reference made herein to any other International Standard implies its latest edition, unless otherwise stated.

Hexagon head screws — Product grades A and B

iTeh STANDARD PREVIEW
(standards.iteh.ai)

0 Introduction

This International Standard is part of the complete ISO product standard series on hexagon drive fasteners. The series comprises:

- a) hexagon head bolts (ISO 4014, ISO 4015, ISO 4016 and ISO 8765);
- b) hexagon head screws (ISO 4017, ISO 4018 and ISO 8676);
- c) hexagon nuts (ISO 4032, ISO 4033, ISO 4034, ISO 4035, ISO 4036, ISO 8673, ISO 8674 and ISO 8675);
- d) hexagon flanged bolts (ISO 4162 and ISO 8102);
- e) hexagon flanged screws;¹⁾
- f) hexagon flanged nuts (ISO 4161, ISO 7043 and ISO 7044);
- g) structural bolting (ISO 4775, ISO 7411 to ISO 7414 and ISO 7417).

1 Scope and field of application

This International Standard gives specifications for hexagon head screws with threads from M1,6 up to and including M64, of product grade A for threads M1,6 to M24 and nominal lengths up to and including $10d$ or 150 mm, whichever is shorter, and product grade B for threads over M24 or nominal lengths over $10d$ or 150 mm, whichever is shorter.

NOTE — This type of product is the same as that covered by ISO 4014 with the exception of threading up to the head and nominal length up to and including 200 mm as popular lengths.

If, in special cases, specifications other than those listed in this International Standard are required, they should be selected from existing International Standards, for example ISO 261, ISO 888, ISO 898-1, ISO 965-2, ISO 3506 and ISO 4759-1.

1) These will form the subjects of future International Standards.

2 References

ISO 225, *Fasteners — Bolts, screws and nuts — Symbols and designations of dimensions.*

ISO 261, *ISO general purpose metric screw threads — General plan.*

ISO 888, *Bolts, screws and studs — Nominal lengths and thread lengths for general purpose bolts and screws.*

ISO 898-1, *Mechanical properties of fasteners — Part 1: Bolts, screws and studs.*

ISO 965-2, *ISO general purpose metric screw threads — Tolerances — Part 2: Limits of sizes for general purpose bolt and nut threads — Medium quality.*

ISO 3269, *Fasteners — Acceptance inspection.*

ISO 3506, *Corrosion-resistant stainless steel fasteners — Specifications.*

ISO 3508, *Thread run-outs and fasteners with thread in accordance with ISO 261 and ISO 262.*

ISO 4042, *Threaded components — Electroplated coatings.*¹⁾

ISO 4753, *Fasteners — Ends of parts with external metric ISO thread.*

ISO 4759-1, *Tolerances for fasteners — Part 1: Bolts, screws and nuts with thread diameters $\geq 1,6$ and ≤ 150 mm and product grades A, B and C.*

ISO 6157-1, *Fasteners — Surface discontinuities — Part 1: Bolts, screws and studs for general requirements.*¹⁾

ISO 6157-3, *Fasteners — Surface discontinuities — Part 3: Bolts, screws and studs for special requirements.*¹⁾

ISO 8839, *Mechanical properties of fasteners — Bolts, screws, studs and nuts made of non-ferrous metals.*

ISO 8992, *Fasteners — General requirements for bolts, screws and nuts.*

ITeC STANDARD PREVIEW
(standards.itec.ai)
ISO 4017:1988
<https://standards.itec.ai/catalog/standards/sist/f4c89c88-183b-4f10-b1be-357e48e0eccf/iso-4017-1988>

1) At present at the stage of draft.

3 Dimensions

NOTE — Symbols and descriptions of dimensions are specified in ISO 225.

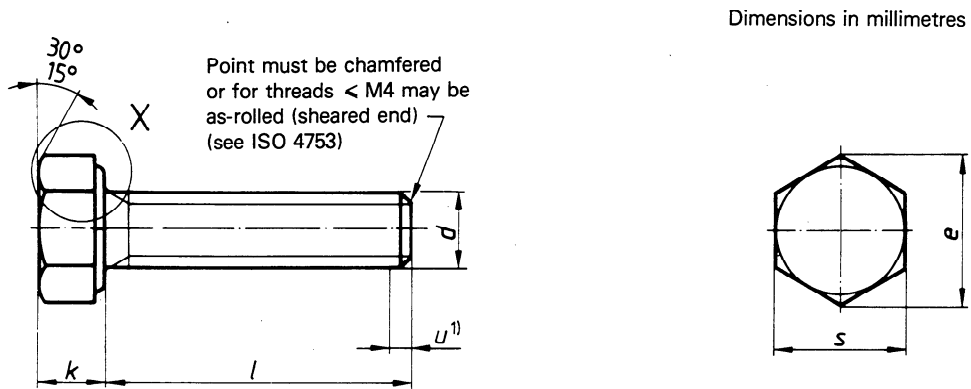

X

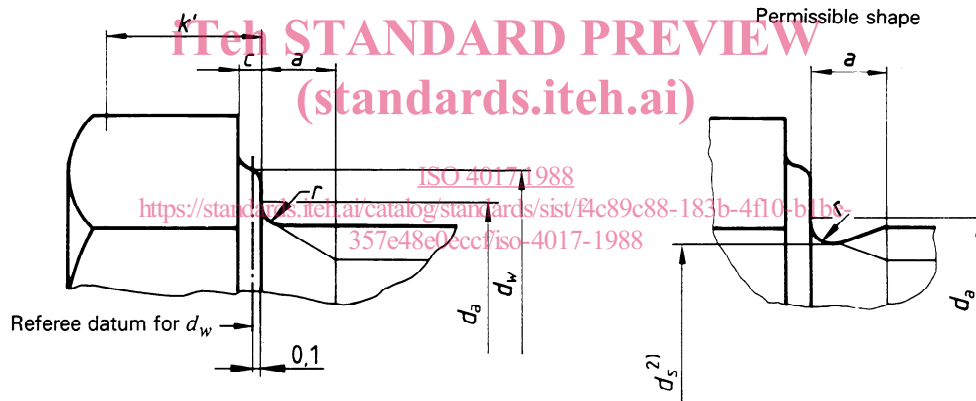

1) Incomplete thread $u < 2P$

2) $d_s \approx$ pitch diameter.

Table 1 — Preferred threads

Thread (d)	Dimensions in millimetres																			
	M1.6	M2	M2.5	M3	M4	M5	M6	M8	M10	M12	M16	M20	M24	M30	M36	M42	M48	M56	M64	
P1)	0,35	0,4	0,45	0,5	0,7	0,8	1	1,25	1,5	1,75	2	2,5	3	3,5	4	4,5	5	5,5	6	
a	max.2)	1,05	1,2	1,35	1,5	2,1	3	4	4,5	5,3	6	7,5	9	10,5	12	13,5	15	16,5	18	
c	min.	0,35	0,4	0,45	0,5	0,7	1	1,25	1,5	1,75	2	2,5	3	3,5	4	4,5	5	5,5	6	
d _a	min.	0,1	0,1	0,15	0,15	0,15	0,15	0,15	0,15	0,15	0,2	0,2	0,2	0,2	0,2	0,3	0,3	0,3	0,3	
d _w	max.	0,25	0,25	0,4	0,4	0,5	0,5	0,6	0,6	0,6	0,8	0,8	0,8	0,8	0,8	1	1	1	1	
e	min.	2	2,6	3,1	3,6	4,7	5,7	6,8	9,2	11,2	13,7	17,7	22,4	26,4	33,4	45,6	52,6	63	71	
k	max.	2,27	3,07	4,07	4,57	6,03	6,88	8,88	11,63	14,63	16,63	22,49	28,19	33,61	42,75	51,11	59,95	69,45	88,16	
Product grade A	min.	3,41	4,32	5,45	6,07	7,66	8,79	11,05	14,38	17,77	20,03	26,75	33,53	39,98	50,85	60,79	71,3	82,6	93,56	
Product grade B	min.	1,1	1,4	1,7	2	2,8	3,5	4	5,3	6,4	7,5	10	12,5	15	18,7	22,5	26	30	35	
Product grade A	max.	0,975	1,275	1,575	1,875	2,675	3,35	3,85	5,15	6,22	7,32	9,82	12,285	14,785	18,28	22,08	25,58	29,58	34,5	
Product grade B	max.	1,225	1,525	1,825	2,125	2,925	3,65	4,15	5,45	6,58	7,68	10,18	12,715	15,215	19,12	22,92	26,42	30,42	35,5	
k'3)	min.	0,68	0,89	1,1	1,31	1,87	2,35	2,7	3,61	4,35	5,12	6,87	8,6	10,35	12,8	15,46	17,91	20,71	24,15	
r	max.	0,1	0,1	0,1	0,1	0,2	0,2	0,25	0,4	0,4	0,6	0,6	0,8	0,8	1	1	1,2	1,6	2	
s	nom. = max.	3,2	4	5	5,5	7	8	10	13	16	18	24	30	36	46	55	65	75	85	
Product grade A	min.	3,02	3,82	4,82	5,32	6,78	7,78	9,78	12,73	15,73	17,73	23,67	29,67	35,38	45	53,8	63,1	73,1	82,8	
Product grade B	min.	—	—	—	—	—	—	—	—	—	—	—	—	—	—	—	—	—	—	
Product grade	A	/ 4)																		
nom.	min.	min.	max.	min.	max.	min.	max.	min.	max.	min.	max.	min.	max.	min.	max.	min.	max.	min.	max.	
2	1,8	2,2	—	—	—	—	—	—	—	—	—	—	—	—	—	—	—	—	—	
3	2,8	3,2	—	—	—	—	—	—	—	—	—	—	—	—	—	—	—	—	—	
4	3,76	4,24	—	—	—	—	—	—	—	—	—	—	—	—	—	—	—	—	—	
5	4,76	5,24	—	—	—	—	—	—	—	—	—	—	—	—	—	—	—	—	—	
6	5,76	6,24	—	—	—	—	—	—	—	—	—	—	—	—	—	—	—	—	—	
8	7,71	8,29	—	—	—	—	—	—	—	—	—	—	—	—	—	—	—	—	—	
10	9,71	10,29	—	—	—	—	—	—	—	—	—	—	—	—	—	—	—	—	—	
12	11,65	12,35	—	—	—	—	—	—	—	—	—	—	—	—	—	—	—	—	—	
16	15,65	16,35	—	—	—	—	—	—	—	—	—	—	—	—	—	—	—	—	—	

20	19,58	20,42	—	—
25	24,58	25,42	—	—
30	29,58	30,42	—	—
35	34,5	35,5	—	—
40	39,5	40,5	—	—
45	44,5	45,5	—	—
50	49,5	50,5	—	—
55	54,4	55,6	—	—
60	59,4	60,6	58,5	61,5
65	64,4	65,6	63,5	66,5
70	69,4	70,6	68,5	71,5
80	79,4	80,6	78,5	81,5
90	89,3	90,7	88,25	91,75
100	99,3	100,7	98,25	101,75
110	109,3	110,7	108,25	111,75
120	119,3	120,7	118,25	121,75
130	129,2	130,8	128	132
140	139,2	140,8	138	142
150	149,2	150,8	148	152
160	—	—	158	162
180	—	—	178	182
200	—	—	197,7	202,3

iTech STANDARD PREVIEW
(standards.itech.ai)

ISO 4017:1988
https://standards.itech.ai/catalog/standards/sist/f4c89c88-183b-4f10-11be-357e18e0ecef/iso-4017-1988

- 1) P = pitch of the thread.
- 2) Values in accordance with a max., normal series, in ISO 3508.
- 3) $k_{min} = 0,7 k_{min}$
- 4) Range of popular lengths between the stepped lines:
 - Product grade A above the stepped line, marked thus — — — — —
 - Product grade B below this stepped line.

Table 2 — Non-preferred threads

Dimensions in millimetres

Thread (d)	M3,5	M14	M18	M22	M27	M33	M39	M45	M52	M60
P ¹⁾	0,6	2	2,5	2,5	3	3,5	4	4,5	5	5,5
a	max. 2)	6	7,5	7,5	9	10,5	12	13,5	15	16,5
	min.	2	2,5	2,5	3	3,5	4	4,5	5	5,5
c	min.	0,15	0,2	0,2	0,2	0,2	0,3	0,3	0,3	0,3
	max.	0,4	0,6	0,8	0,8	0,8	1	1	1	1
d _a	max.	4,1	15,7	24,4	24,4	36,4	42,4	48,6	56,6	67
	min.	5,07	19,37	25,34	31,71	—	—	—	—	—
d _w	min.	—	24,85	31,35	38	46,55	55,86	64,7	74,2	83,41
	max.	—	23,36	30,14	37,72	—	—	—	—	—
e	min.	6,58	23,36	29,56	37,29	55,37	66,44	76,95	88,25	99,21
	max.	—	8,8	11,5	14	21	25	28	33	38
k	min.	2,275	8,62	11,285	13,785	—	—	—	—	—
	max.	2,525	8,98	11,715	14,215	—	—	—	—	—
k'(3)	min.	—	—	11,15	13,65	20,58	24,58	27,58	32,5	37,5
	max.	—	—	11,85	14,35	21,42	25,42	28,42	33,5	38,5
r	min.	1,59	6,03	7,9	9,65	—	—	—	—	—
	max.	—	—	7,81	9,56	14,41	17,21	19,31	22,75	26,25
s	min.	0,1	0,6	0,6	0,8	1	1	1,2	1,6	2
	max.	6	21	27	34	41	60	70	80	90
Product grade	A	5,82	20,67	26,67	33,38	—	—	—	—	—
	B	—	—	26,16	33	40	58,8	68,1	78,1	87,8
/ 4)										
nom.	min.	7,71	8,29	—	—	—	—	—	—	—
	max.	9,71	10,29	—	—	—	—	—	—	—
	min.	11,65	12,35	—	—	—	—	—	—	—
	max.	15,65	16,35	—	—	—	—	—	—	—
	min.	19,58	20,42	—	—	—	—	—	—	—
	max.	24,58	25,42	—	—	—	—	—	—	—
	min.	29,68	30,42	—	—	—	—	—	—	—
	max.	34,5	35,5	—	—	—	—	—	—	—
	min.	39,5	40,5	—	—	—	—	—	—	—

