



Designation: B49 – 17

Standard Specification for Copper Rod for Electrical Purposes¹

This standard is issued under the fixed designation B49; the number immediately following the designation indicates the year of original adoption or, in the case of revision, the year of last revision. A number in parentheses indicates the year of last reapproval. A superscript epsilon (ϵ) indicates an editorial change since the last revision or reapproval.

This standard has been approved for use by agencies of the U.S. Department of Defense.

1. Scope*

1.1 This specification covers the requirements for rod in diameters from $\frac{1}{4}$ to $1\frac{3}{8}$ in. (6.4 to 35 mm) produced from high conductivity coppers listed in Table 1, namely, electrolytic tough-pitch, oxygen-free, or fire-refined high conductivity coppers, and are suitable for further fabrication into electrical conductors.

1.2 The values stated in inch-pound units are to be regarded as standard. The values given in parentheses are mathematical conversions to SI units that are provided for information only and are not considered standard.

1.3 The following safety hazards caveat pertains only to Section 13. *This standard does not purport to address all of the safety concerns, if any, associated with its use. It is the responsibility of the user of this standard to establish appropriate safety and health practices and determine the applicability of regulatory limitations prior to use.*

1.4 *This international standard was developed in accordance with internationally recognized principles on standardization established in the Decision on Principles for the Development of International Standards, Guides and Recommendations issued by the World Trade Organization Technical Barriers to Trade (TBT) Committee.*

2. Referenced Documents

2.1 The following documents in the current issue of the Book of Standards form a part of this specification to the extent referenced herein and define materials suitable for use in rod manufacture:

2.2 *ASTM Standards*:²

B5 Specification for High Conductivity Tough-Pitch Copper Refinery Shapes

¹ This specification is under the jurisdiction of ASTM Committee B05 on Copper and Copper Alloys and is the direct responsibility of Subcommittee B05.07 on Refined Copper.

Current edition approved April 1, 2017. Published May 2017. Originally approved in 1923. Last previous edition approved in 2016 as B49-16. DOI: 10.1520/B0049-17.

² For referenced ASTM standards, visit the ASTM website, www.astm.org, or contact ASTM Customer Service at service@astm.org. For *Annual Book of ASTM Standards* volume information, refer to the standard's Document Summary page on the ASTM website.

- [B115 Specification for Electrolytic Copper Cathode](#)
 - [B170 Specification for Oxygen-Free Electrolytic Copper—Refinery Shapes](#)
 - [B193 Test Method for Resistivity of Electrical Conductor Materials](#)
 - [B224 Classification of Coppers](#)
 - [B577 Test Methods for Detection of Cuprous Oxide \(Hydrogen Embrittlement Susceptibility\) in Copper](#)
 - [B846 Terminology for Copper and Copper Alloys](#)
 - [E8/E8M Test Methods for Tension Testing of Metallic Materials](#)
 - [E18 Test Methods for Rockwell Hardness of Metallic Materials](#)
 - [E29 Practice for Using Significant Digits in Test Data to Determine Conformance with Specifications](#)
 - [E53 Test Method for Determination of Copper in Unalloyed Copper by Gravimetry](#)
 - [E478 Test Methods for Chemical Analysis of Copper Alloys](#)
 - [E1606 Practice for Electromagnetic \(Eddy Current\) Examination of Copper and Aluminum Redraw Rod for Electrical Purposes](#)
 - [E2575 Standard Test Method for Determination of Oxygen in Copper and Copper Alloys \(Withdrawn 2017\)³](#)
- 2.3 *Other Document*:⁴
- [NBS Handbook 100 Copper Wire Tables](#)

3. Terminology

3.1 For definitions of general terms relating to copper and copper alloys refer to Terminology **B846**.

4. Ordering Information

4.1 Orders for rod under this specification shall include the following information:

- 4.1.1 ASTM designation and year of issue,
- 4.1.2 Quantity of each size,
- 4.1.3 UNS designation and requirements of copper (Sections **5 – 10**),
- 4.1.4 Finish (Sections **9 and 10**),

³ The last approved version of this historical standard is referenced on www.astm.org.

⁴ Available from National Technical Information Service (NTIS), 5301 Shawnee Rd., Alexandria, VA 22312, http://www.ntis.gov.

*A Summary of Changes section appears at the end of this standard

- 4.1.5 Package with or without joints (see 5.3),
- 4.1.6 Rod diameter (see 9.2),
- 4.1.7 Inspection (Section 15),
- 4.1.8 Package size (see 19.1), and
- 4.1.9 Special package marking as agreed upon between the manufacturer and the purchaser (Section 19).

4.2 The following requirements are optional and should be specified in the contract or purchase order when required.

- 4.2.1 Certification (Section 17) and
- 4.2.2 Test Report (Section 18).

5. Material and Manufacture

5.1 The rod shall be fabricated from copper of such quality and purity that the finished product shall have the properties and characteristics prescribed in this specification.

NOTE 1—The following specifications define materials suitable for use: Classification B224, or Specification B5, or Specification B115, or Specification B170.

5.2 Copper of special qualities, forms, or types, as agreed upon between the manufacturer and the purchaser and that will conform to the requirements prescribed in this specification may also be used.

5.3 The rod coils shall be furnished in continuous lengths with or without joints, as ordered.

6. Chemical Composition

6.1 Each rod type shall conform to the chemical composition requirements prescribed in Table 1 for the type of copper ordered (Section 5).

6.2 By agreement between the manufacturer and the purchaser, the addition of silver up to an average of 30 troy oz per short ton of copper (0.10 %) will be considered within the specification, copper including silver in the chemical analysis, with no individual silver analysis to exceed 35 troy oz per short ton (0.12 %). In the case of oxygen-free silver-bearing coppers, the designation OFS (oxygen-free, silver-bearing) will be used as shown in Classification B224 and will include the UNS Nos. C10400, C10500, and C10700 as defined by the agreed silver content.

6.3 Silver-bearing tough-pitch copper corresponds to the designation STP (silver-bearing tough-pitch) as shown in Classification B224 and to coppers having UNS Nos. C11300, C11400, C11500, and C11600.

6.4 *Oxygen Content*—Oxygen-free copper as described herein is defined as a copper containing not in excess of 0.0010 % (10 ppm) oxygen and produced without the use of metallic or other deoxidizers.

7. Physical Property Requirements

7.1 *Electrical Resistivity*—Resistivity of the copper in the annealed condition (See Note X1.1 and Table 2) shall not exceed the following values at 20 °C:

Type of Copper	Resistivity, max, at 20 °C Annealed, Ω · g/m ²
UNS C10100 only	0.15176 (101.00 % IACS min)
All others	0.15328 (100.00 % IACS min)

TABLE 1 Chemical Composition^A

UNS Number Copper Type	C11000 ETP	C11040 ETP	C10100 OFE ^B	C10200 OF ^C
Copper, min	99.90 % ^D incl silver	99.90 % ^E	99.99 % ^E	99.95 % ^D incl silver
	ppm	ppm	ppm	ppm
Tellurium, max	...	2	2	...
Selenium, max	...	2	3	...
Bismuth, max	...	1.0	1.0	...
Group total, max	...	3
Antimony, max	...	4	4	...
Arsenic, max	...	5	5	...
Tin, max	...	5	2	...
Lead, max	...	5	5	...
Iron, max	...	10	10	...
Nickel, max	...	10	10	...
Sulfur, max	...	15	15	...
Silver, max	...	25	25	...
Oxygen	...	100–650	5 max	10 max
Maximum allowable total	...	65 ^F
Cadmium, max	1	...
Phosphorus, max	3	...
Zinc, max	1	...
Manganese, max	0.5	...
Fire-Refined Coppers				
UNS Number Copper Type	C11020 FRHC	C11025 FRHC		
Copper, min	99.90 % ^D	99.90 % ^D		
	incl silver			
Tellurium, max	...	10		
Selenium, max	...	10		
Bismuth, max	...	5		
Group total, max		
Antimony, max	...	50		
Arsenic, max	...	10		
Tin, max	...	150		
Lead	...	150–450		
Iron, max	...	20		
Nickel, max	...	150		
Sulfur, max	...	20		
Silver, max	...	150		
Oxygen	...	100–400		
Maximum allowable total	...	750 ^F		
Cadmium, max	...	100		
Phosphorus, max		
Zinc, max	...	80		
Manganese, max		

^A See 13.1.2.
^B From Specification B170 Grade 1 copper or equivalent.
^C From Specification B170 Grade 2 copper or equivalent.
^D See 13.1.1.
^E By difference. See 13.1.2 and 13.1.3.
^F Not including oxygen.

TABLE 2 Equivalent Resistivity Values^A

Conductivity at 68 °F (20 °C), % IACS	100.00	101.00
Ω · lb/mile ²	875.20	866.53
Ω · g/m ²	0.153 28	0.151 76
Ω · c mil/ft	10.371	10.268
Ω · mm ² /m	0.017 241 0	0.017 070
μΩ · in.	0.678 79	0.672 07
μΩ · cm	1.7241	1.7070

^A The equivalent resistivity values for 100 % IACS (soft copper) were each computed from the fundamental IEC value (1/58 Ω · mm²/m) using conversion factors each accurate to at least seven significant figures.

8. Mechanical Property Requirements

8.1 *Tensile Tests*—Rod finished by hot working or annealing shall have a minimum elongation of 30 % in 10 in. (250 mm). (Note X1.2 and Test Methods E8/E8M.)

8.2 *Torsion (Twist) Tests*—Torsion tests are not a requirement of this specification. However, a discussion will be found in [Note X1.3](#).

8.3 *Embrittlement (Bend) Test:*

8.3.1 A test to reflect propensity towards hydrogen embrittlement shall be performed only on oxygen-free copper.

8.3.2 The specimen shall be tested in accordance with [13.6](#) and Specification [B170](#).

8.3.3 The specimen, prepared and tested from the OFE (oxygen-free electronic) copper (UNS C10100) listed in [Table 1](#), shall withstand without breaking into two pieces, a minimum of ten (10) reverse bends.

8.3.4 The specimen, prepared and tested from the OF (oxygen-free) copper (UNS C10200) listed in [Table 1](#), shall withstand, without breaking into two pieces, a minimum of eight (8) reverse bends.

8.4 *Annealability*—Annealability is not a requirement of this specification. However, a discussion will be found in [Note X1.4](#), [Note X1.5](#), [Note X1.6](#), and [Note X1.7](#).

9. Other Requirements

9.1 *Surface Oxide*—The surface oxide film thickness shall be determined in accordance with [13.5](#).

9.1.1 Total thickness of the copper oxide film on cleaned copper rod or annealed shaved rod or cold-finished rod shall not exceed 750 Å (7.5×10^{-8} m).

9.1.2 The residual oxide film thickness on as-shaved rod does not need to be specified.

9.1.3 A surface oxide requirement is not necessary for rod ordered uncleaned.

9.2 *Diameter*—The diameter of the rod at any point shall not vary from that specified by more than the amounts prescribed in [Table 3](#).

TABLE 3 Permissible Variations in Diameter

Nominal Diameter, in. (mm)	Permissible Variation, in. (mm)
¼ (6.4)	+0.020 (+0.51) −0.010 (−0.25)
Over ¼ (6.4) to ¾ in. (19 mm) incl.	±0.015 (±0.38)
Over ¾ (19) to 1.0 in. (25 mm) incl.	±0.020 (±0.51)
Over 1.0 (25) to 1 ⅝ in. (35 mm) incl.	±0.030 (±0.76)

9.3 *Electromagnetic (Eddy-current) Examination*—Electromagnetic examination of copper redraw rod is not a requirement of this specification. If it is performed for detecting surface discontinuities, however, a discussion will be found in [Note X1.8](#).

10. Workmanship, Finish, and Appearance

10.1 The rod shall be free of defects, but blemishes of a nature that do not interfere with the intended application are acceptable.

11. Sampling

11.1 *Routine Sampling*—For the routine analysis of copper rod coils, the methods of sampling shall be at the discretion of the tester.

11.2 This procedure shall be used in case of rod dispute between the manufacturer and the purchaser.

11.2.1 A lot shall be considered as a single coil of finished rod. A minimum of two samples of sufficient length shall be taken from the suspected non-conforming rod coil for retesting. Samples may be taken from either end of the rod coil at the discretion of the tester. Specific numbers and locations shall be determined between the producer and user. If the test pieces from both test samples pass the appropriate test(s), then the coil shall be deemed to conform to the particular requirement(s) of the standard. If a test piece fails a test, the rod coil represented in the shipping lot shall be deemed not to conform to this standard.

11.2.2 A shipping lot shall be the quantity of rod in coil form that is present in a single container, such as a truck or railroad car.

11.3 When a cast refinery shape has been chemically analyzed and converted into rod without remelting, further chemical analysis shall not be required.

12. Number of Tests and Retests

12.1 Tests:

12.1.1 *Chemical Analysis*—Chemical composition shall be determined in accordance with the element mean of the results from at least two replicate analyses of the sample(s).

12.1.2 Other Tests:

12.1.2.1 *Electrical Resistivity, Tensile Elongation, Diameter, and Surface Oxide*—Results shall be reported as the average obtained from at least two test specimens, each taken from a separate test piece where possible.

12.1.2.2 *Hydrogen Embrittlement Test and Microscopical Examination*—All specimens tested must meet the requirements of the specification.

12.2 Retests:

12.2.1 When requested by the manufacturer or supplier, a retest shall be permitted when results of tests obtained by the purchaser fail to conform to the requirements of the product specification.

12.2.2 The retest shall be as directed in the product specification for the initial test except the number of test specimens shall be twice that normally required for the specified test.

12.2.3 All test specimens shall conform to the product specification requirement(s) in retest. Failure to conform shall be cause for rejection.

13. Test Methods

13.1 Chemical Analysis:

13.1.1 In case of dispute, copper content of the coppers other than UNS C10100 and UNS C11040 in [Table 1](#) shall be determined in accordance with Test Method [E53](#).

13.1.2 Analytical method for determining impurity levels of coppers listed in [Table 1](#) shall be in accordance with Specification [B115](#).

13.1.3 Copper content of UNS C10100 and UNS C11040 types shall be calculated by subtracting from 100 % the total impurity concentration determined. The impurity total for UNS C10100 is defined as the sum of sulfur, silver, lead, tin, bismuth, arsenic, antimony, iron, nickel, zinc, phosphorus,

selenium, tellurium, manganese, cadmium, and oxygen present in the sample. The impurity total for UNS C11040 is defined as the sum of sulfur, silver, lead, tin, bismuth, arsenic, antimony, iron, nickel, selenium, tellurium, and oxygen present in the sample.

13.1.4 The test methods annex of Specification B170 should be referenced for the oxygen-free coppers. Test Methods E478 should be referenced for the determination of silver-bearing alloys permitted under this specification.

13.1.5 Oxygen content shall be determined on cleaned copper samples using a suitable laboratory apparatus or a commercial instrument designed specifically for this purpose. Test Method E2575 shall be referenced to determine oxygen content in copper and copper alloys only for the range 5 to 400 ppm since standards have not been developed above this range.

13.2 *Tensile Elongation*—Elongation shall be determined as the permanent increase in length, caused by breaking of the rod in tension, measured between gage marks placed originally 10 in. (250 mm) apart upon the test specimen (Note X1.2). The fracture shall be between gage marks and not closer than 1 in. (25 mm) to either gage mark.

13.3 *Electrical Resistivity:*

13.3.1 At the option of the manufacturer, electrical resistivity shall be determined in accordance with 13.3.2 or 13.3.3. However, in case of dispute, 13.3.2 shall apply.

13.3.2 Resistance measurements (Note X1.1) shall be made on specimens of the rod after cleaning and processing down to a diameter of approximately 0.080 in. (2.0 mm) and annealing at approximately 932 °F (500 °C) for 30 min. Other equivalent annealing methods may be used. Test specimens processed to a diameter other than 0.080 in. may be used if agreed upon between the manufacturer and the purchaser.

13.3.3 Resistance measurements may be determined on specimens of the rod after cleaning, but without further processing and annealing. However, in the event of failure of a rod specimen to conform to the criteria of 7.1, a retest is permitted using the procedure of 13.3.2.

13.3.4 Electrical resistivity shall be determined in accordance with Test Method B193 except that when the option of 13.3.3 is elected, the plus and minus tolerance for the cross-sectional area as specified in Test Method B193 shall not apply.

13.4 *Diameter*—Diameter of the rod shall be measured with a suitable measuring device, micrometer, caliper or other, reading at least to the nearest 0.001 in. (0.02 mm).

13.5 *Surface Oxide:*

13.5.1 The thickness and type of unreduced oxide films remaining on the surface of rod after cleaning shall be determined by an electrolytic reduction method. This test shall

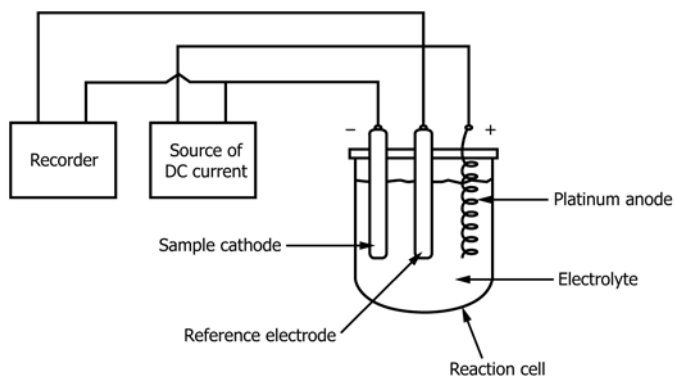

FIG. 1 Schematic Illustration Showing Electrolytic Reduction Test Method

be performed by reducing the surface oxide(s) to copper in an electrolytic cell.⁵ As shown by the schematic diagram in Fig. 1, the test sample is made cathodic with respect to an anode, which shall be made from a platinum wire or an equivalent inert electrode. Current shall be supplied from a dc power supply or a coulometer. A discussion on means to help improve accuracy and repeatability of this test method will be found in Note X1.9.

13.5.2 Each of the oxides found on copper, namely cuprous and cupric, are reduced sequentially to copper at different reduction potentials, and the voltages are to be recorded against time during the entire test. When the individual reactions between the oxides and hydrogen ions are complete, gaseous hydrogen is evolved and may be seen visually at the surface of the copper rod sample.

13.5.3 A typical curve of voltage versus time is presented in Fig. 2. Cuprous oxide is reduced initially. When this reaction is complete, reduction of the cupric oxide occurs at a higher voltage.

13.5.4 Thickness of each oxide present shall be calculated as follows:

$$T = \frac{ItM}{SdFn} \tag{1}$$

⁵ For a description of a similar, yet alternative standard procedure to determine tarnish films on coupons exposed to environmental tests, see "Monitoring Environmental Tests by Coulometric Reduction of Metallic Control Samples," *Journal of Testing and Evaluation*, 1989, pp. 357-367, ASTM. Also refer to "The Role of Surface Oxide and Its Measurement in the Copper Wire Industry," *Wire Journal*, March 1977, pp. 50-57, and "Analysis and Automation of Copper Surface Oxide Measurement," *Wire Journal*, February 1999, pp. 90-97, and "New Developments in Rod Surface Measurement and Analysis," *Wire Journal*, December, 2009, pp. 72-78.