



# Standard Test Method for Determining Atmospheric Chloride Deposition Rate by Wet Candle Method<sup>1</sup>

This standard is issued under the fixed designation G 140; the number immediately following the designation indicates the year of original adoption or, in the case of revision, the year of last revision. A number in parentheses indicates the year of last reapproval. A superscript epsilon ( $\epsilon$ ) indicates an editorial change since the last revision or reapproval.

## 1. Scope

1.1 This test method describes a wet candle device and its use in measuring atmospheric chloride deposition (amount of chloride salts deposited from the atmosphere on a given area per unit time).

1.2 Data on atmospheric chloride deposition can be useful in classifying the corrosivity of a specific area, such as an atmospheric test site. Caution must be exercised, however, to take into consideration the season because airborne chlorides vary widely between seasons.

1.3 *This standard does not purport to address all of the safety concerns, if any, associated with its use. It is the responsibility of the user of this standard to establish appropriate safety and health practices and determine the applicability of regulatory limitations prior to use.*

## 2. Referenced Documents

### 2.1 ASTM Standards:

- D 1129 Terminology Relating to Water<sup>2</sup>
- D 1193 Specification for Reagent Water<sup>2</sup>
- D 2777 Practice for Determination of Precision and Bias of Applicable Test Methods of Committee D-19 on Water<sup>2</sup>
- D 4458 Test Method for Chloride Ions in Brackish Water, Seawater, and Brines<sup>2</sup>
- G 92 Practice for Characterization of Atmospheric Test Sites<sup>3</sup>

### 2.2 ISO Standard:

- ISO 9225 Corrosion of Metals and Alloys. Aggressivity of Atmospheres—Methods of Measurement of Pollution Data<sup>4</sup>

## 3. Significance and Use

3.1 This test method is capable of generating quantitative values of atmospheric chloride deposition specifying milligrams of chloride ions per square metre per day (or other units derived from such values).

<sup>1</sup> This test method is under the jurisdiction of ASTM Committee G-1 on Corrosion of Metals and is the direct responsibility of Subcommittee G01.04 on Atmospheric Corrosion.

Current edition approved July 10, 1996. Published September 1996.

<sup>2</sup> *Annual Book of ASTM Standards*, Vol 11.01.

<sup>3</sup> *Annual Book of ASTM Standards*, Vol 03.02.

<sup>4</sup> Available from American National Standards Institute, 11 W. 42nd St., 13th Floor, New York, NY 10036.

NOTE 1—Chlorides in the atmosphere exist as a suspension of liquid droplets or solid particles. They are transported to solid surfaces by gravity, wind, or brownian motions. These transport mechanisms are direction-sensitive so that a vertical cylinder will not necessarily receive the same flux as a horizontal plate, or objects with different sizes and orientations. Therefore, the use of this approach to provide an indication of the deposition of chlorides on objects in atmospheric exposures may not be quantitatively accurate; however, this technique has been successful in classifying the severity of exposure in a variety of marine locations.

3.2 The sites where samples are to be taken and the sampling time periods should be established. A program of six 30-day exposures per year for a period of three years is recommended. More extensive testing may be desirable if large variability is encountered in the results.

## 4. Apparatus

4.1 *Components*—The components needed to construct one wet candle device are as follows:

4.1.1 *Erlenmeyer Flask*, narrow mouth, 500 mL, (glass or polypropylene). Other size flasks may be used, but dimensions in Fig. 1 will have to be adjusted accordingly.

NOTE 2—Polypropylene flasks are recommended during threat of freezing weather.

4.1.2 *Glass Test Tube*, general purpose, 16 by 150-mm length.

4.1.3 *Solid Rubber or Neoprene Stopper*, No. 7, diameter top 38 mm, bottom 30 mm.

4.1.4 *Cotton Bandage Gauze*, strip, 50 mm wide and approximately 1500 mm long.

NOTE 3—The overall length of the gauze may vary with installation.

4.1.5 *Type IV Reagent Water*, 1 L, 200 mL CHOH (CH<sub>2</sub>OH<sub>2</sub>) (glycerin) and 20 drops CH<sub>3</sub>(CH<sub>2</sub>)<sub>6</sub>COOH (octanoic acid) should be added to prevent freezing, if necessary.

4.1.6 *Gloves*, vinyl, one pair.

NOTE 4—Poly(vinyl chloride) (PVC) is recommended. Latex gloves are not acceptable, as their chloride content is reported to be comparable to that of human hands.

4.2 *Support Stand*—A suitable support stand shall be erected at the site where the atmosphere is to be sampled. A treated wood post (100 by 100 by 2250 mm) or galvanized pipe (42-mm diameter by 2250-mm length) with an attached plate on top are suitable, with 750 mm in the ground and 1500 mm above the ground on which the apparatus to hold the candle can

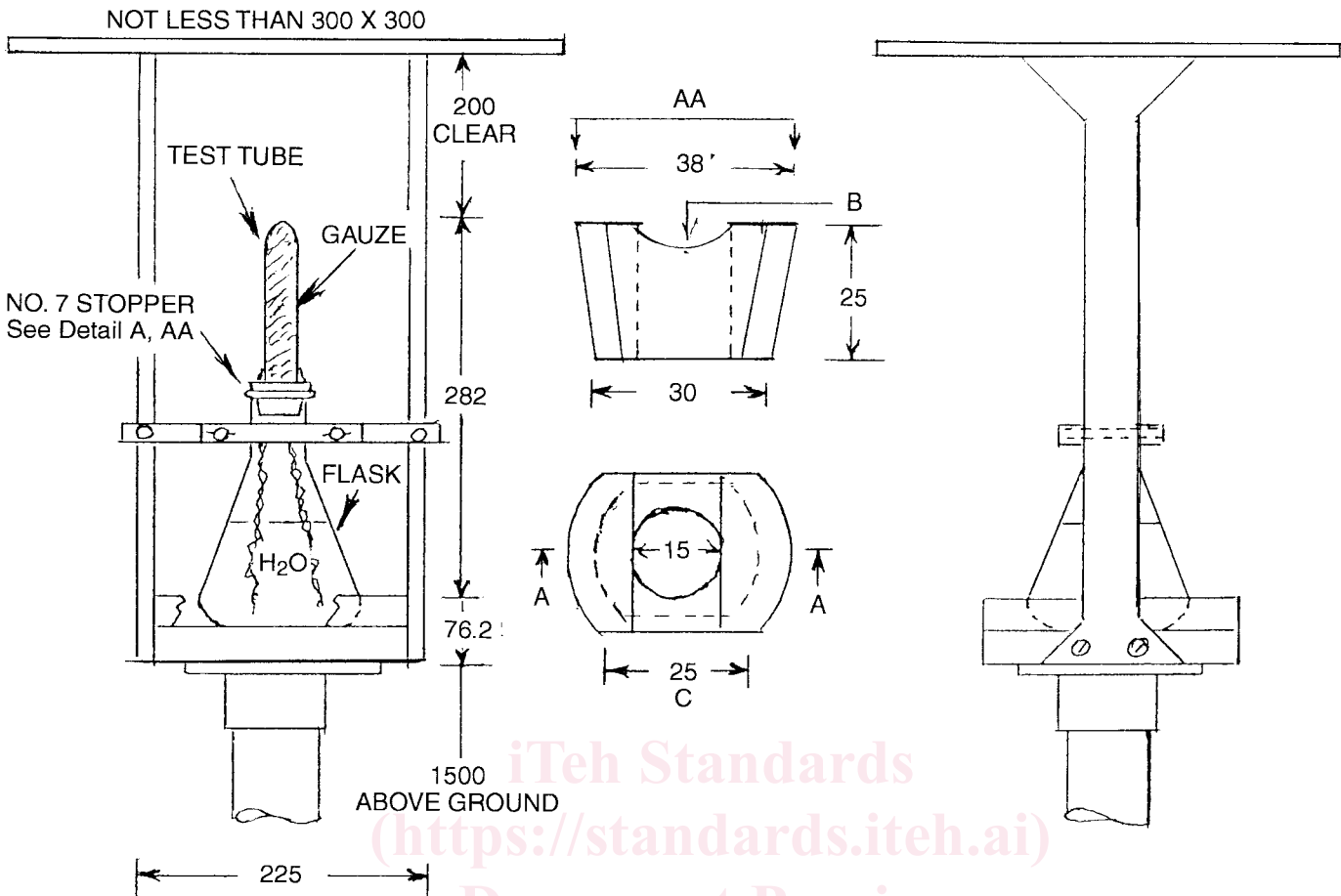

NOTE 1—Dimensions are in millimetres (mm).  
**FIG. 1 Wet Candle Chloride Apparatus**

be mounted (see Fig. 1). The apparatus shall be mounted so that the arms supporting the rain cover do not shield the gauze from a known source of chloride.

4.3 *Assembly of the Wet Candle Apparatus* (see Fig. 1):

4.3.1 The rubber stopper must be modified.

4.3.1.1 In the center, bore a hole 15 mm in diameter through the stopper.

4.3.1.2 On opposite sides of the conical surface of the stopper, cut or grind a channel or flat, from top to bottom, sufficiently wide (~25 mm) for the gauze to pass freely between the stopper and the neck of the flask when the stopper is installed tightly in the flask (see Fig. 1).

4.3.2 Insert the test tube upward through the hole in the rubber stopper so that the lip of the tube is at the bottom of the small end of the stopper.

4.3.2.1 The flask and tube/stopper assembly should be rinsed with Type IV reagent water to remove any contaminants.

4.3.3 Cover bare hands with gloves (PVC or other plastic (see Note 4). With freshly opened bandage gauze (50 mm wide), start with a wick 150 mm in length, pass through one channel in the stopper and tightly wrap all the exposed area of the tube. Using overlapping turns, move up the tube covering the top, then back down the tube to the stopper, pass the gauze through the other channel in the stopper, leaving another section of the gauze approximately equal in length to the first (150 mm).

NOTE 5—The total area of exposed gauze will be approximately 0.01 m<sup>2</sup>.

4.3.4 Rinse gauze with Type IV reagent water and fill the flask with 350 of mL Type IV reagent water (see 4.1.5).

4.3.5 Insert wick ends of gauze into flask and press stopper/tube assembly firmly into flask.

4.3.6 Care while handling and transporting candles is of utmost importance to prevent contamination by perspiration or other means. It is good practice to cover the assembled candle, either before or after filling the flask, with a protective shield to prevent accidental contamination during storage and transport, and also following retrieval for analysis. A polyethylene bag approximately 75 mm (3 in.) by 230 mm (9 in.) or plastic wrap has been found satisfactory. If a bag is used, it can be secured to the flask with a rubber band.

**5. Procedure**

5.1 *Exposure of Wet Candle:*

5.1.1 Place a wetted candle in the support stand. Remove the protective shield, and if not previously filled, handling the tube and stopper by the protective shield, remove the stopper and wick from the flask sufficiently to add 350 mL of Type IV reagent water. Replace the stopper. Record the exposure time and date, and any other pertinent conditions of the exposure.

5.1.2 A predetermined exposure period shall have been established (see 3.2). The exposure period may require that the