International Standard



4033

INTERNATIONAL ORGANIZATION FOR STANDARDIZATION • МЕЖДУНАРОДНАЯ ОРГАНИЗАЦИЯ ПО СТАНДАРТИЗАЦИИ • ORGANISATION INTERNATIONALE DE NORMALISATION

Hexagon nuts, style 2 — Product grades A and B

Écrous hexagonaux, style 2 — Classes de produit A et B

First edition — 1979-06-15

iTeh STANDARD PREVIEW
(standards.iteh.ai)

[ISO 4033:1979](https://standards.iteh.ai/catalog/standards/sist/177d1e1d-fcac-4a05-af2f-ed5946cba462/iso-4033-1979)

<https://standards.iteh.ai/catalog/standards/sist/177d1e1d-fcac-4a05-af2f-ed5946cba462/iso-4033-1979>

UDC 621.882.31

Ref. No. 4033-1979 (E)

Descriptors : fasteners, nuts, hexagonal nuts, specifications, dimensions, designation.

FOREWORD

ISO (the International Organization for Standardization) is a worldwide federation of national standards institutes (ISO member bodies). The work of developing International Standards is carried out through ISO technical committees. Every member body interested in a subject for which a technical committee has been set up has the right to be represented on that committee. International organizations, governmental and non-governmental, in liaison with ISO, also take part in the work.

Draft International Standards adopted by the technical committees are circulated to the member bodies for approval before their acceptance as International Standards by the ISO Council.

International Standard ISO 4033 was developed by Technical Committee ISO/TC 2, *Fasteners*, and was circulated to the member bodies in December 1977.

It has been approved by the member bodies of the following countries :

Australia	Hungary	Poland
Belgium	India	Romania
Canada	Ireland	South Africa, Rep. of
Chile	Israel	Spain
Czechoslovakia	Korea, Rep. of	Sweden
Denmark	Mexico	Turkey
Egypt, Arab Rep. of	Netherlands	United Kingdom
Finland	New Zealand	USA
Germany, F.R.	Norway	Yugoslavia

The member bodies of the following countries expressed disapproval of the document on technical grounds :

France
USSR

Hexagon nuts, style 2 – Product grades A and B

iTeh STANDARD PREVIEW
(standards.iteh.ai)

0 INTRODUCTION

This International Standard is part of the complete ISO product standards series on hexagon drive fasteners. The series comprises :

- a) Hexagon head bolts (ISO 4014, ISO 4015 and ISO 4016)
 - b) Hexagon head screws (ISO 4017 and ISO 4018)
 - c) Hexagon nuts (ISO 4032, ISO 4033, ISO 4034, ISO 4035 and ISO 4036)
 - d) Hexagon flanged bolts
 - e) Hexagon flanged screws
 - f) Hexagon flanged nuts
 - g) Structural bolting
- } (in preparation)

1 SCOPE AND FIELD OF APPLICATION

This International Standard gives specifications for hexagon

nuts, style 2, with metric dimensions and thread diameters from 5 up to and including 36 mm, with product grade A for sizes \leq M16 and product grade B for sizes $>$ M16.

NOTE – For hexagon nuts style 1, see ISO 4032.

2 REFERENCES

ISO 261, *ISO general purpose metric screw threads – General plan.*

ISO 898, *Mechanical properties of fasteners.*

ISO 965, *ISO general purpose metric screw threads – Tolerances.*

ISO 4759/1, *Tolerances for fasteners – Part 1 : Bolts, screws and nuts with thread diameters \geq 1,6 \leq 150 mm and product grades A, B and C.*

3 DIMENSIONS

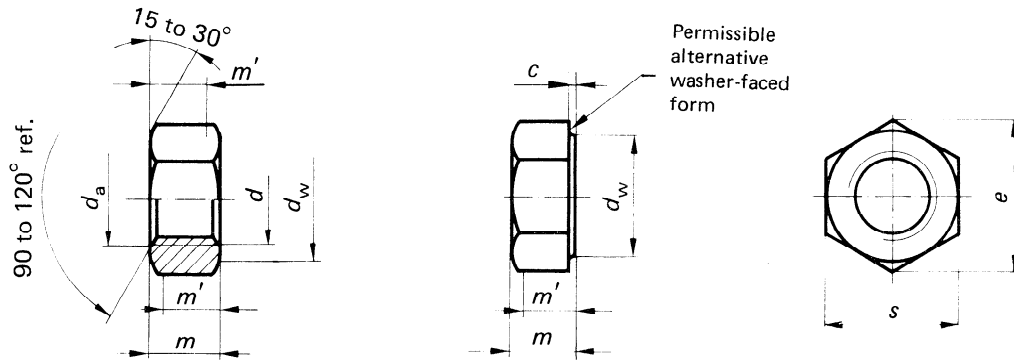

Dimensions in millimetres

Thread size d		M5	M6	M8	M10	M12	(M14)
P	1)	0,8	1	1,25	1,5	1,75	2
c	max.	0,5	0,5	0,6	0,6	0,6	0,6
d_a	min.	5,1	6	8	10	12	14
	max.	5,75	6,75	8,75	10,8	13	15,1
d_w	min.	6,9	8,9	11,6	14,6	16,6	19,6
e	min.	8,79	11,05	14,38	17,77	20,03	23,35
m	max.	5,1	5,7	7,5	9,3	12	14,1
	min.	4,8	5,4	7,14	8,94	11,57	13,4
m'	min.	3,84	4,32	5,71	7,15	9,26	10,7
s	max.	8	10	13	16	18	21
	min.	7,78	9,78	12,73	15,73	17,73	20,67

Thread size d		M16	M20	M24	M30	M36
P	1)	2	2,5	3	3,5	4
c	max.	0,8	0,8	0,8	0,8	0,8
d_a	min.	16	20	24	30	36
	max.	17,3	21,6	25,9	32,4	38,9
d_w	min.	22,5	27,7	33,2	42,7	51,1
e	min.	26,75	32,95	39,55	50,85	60,79
m	max.	16,4	20,3	23,9	28,6	34,7
	min.	15,7	19	22,6	27,3	33,1
m'	min.	12,6	15,2	18,1	21,8	26,5
s	max.	24	30	36	46	55
	min.	23,67	29,16	35	45	53,8

1) P = pitch of the thread.

Sizes in brackets should be avoided if possible.

4 SPECIFICATIONS AND REFERENCE STANDARDS

Material		Steel
Thread	Tolerance	6H
	International Standards	ISO 261, ISO 965
Mechanical properties	Classes	9-12
	International Standard	ISO 898/2
Tolerances	Product grade	A for products with $d \leq M 16$ B for products with $d > M 16$
	International Standard	ISO 4759/1
Finish		as processed Requirements for electroplating are covered in ISO . . . ¹⁾ If different electroplating requirements are desired or if requirements are needed for other finishes, they should be negotiated between customer and supplier.
Acceptability		For acceptance procedure see ISO . . . ¹⁾ .

1) In preparation.

(standards.iteh.ai)

5 DESIGNATION

ISO 4033:1979

<https://standards.iteh.ai/catalog/standards/sist/177d1e1d-fcac-4a05-af2f>

Example for the designation of a hexagon nut with metric thread $d = M12$ and property class 9 :

Hexagon nut ISO 4033 M12-9

ANNEX

This annex is included for explanatory and informative purposes only and is not to be considered as part of this International Standard.

This International Standard incorporates some changes, primarily in width across flats, from the previous metric practice in a number of countries. These changes were made to achieve international agreement and to improve product design and utilization of material.

At its meeting in May 1977, ISO/TC 2 studied several technical reports analysing design considerations influencing determination of the best series of widths across flats for hexagon bolts, screws and nuts. A primary technical objective was to achieve a logical ratio between underhead bearing surface area (which determines the magnitude of

the compressive stress on the bolted members) and the tensile stress area of the screw thread (which governs the clamping force which can be developed by tightening the fastener.)

Table 1 lists the ratios for the sizes selected by ISO/TC 2 to be ISO standard (bold type) and in addition four sizes (light type) which currently are being produced and used in substantial quantities in many countries of the world.

The four sizes (widths across flats of 15, 17, 19 and 22 mm) will be phased out of production and use. During a transitional period, to assist designers and manufacturers, and in particular to give needed information for maintenance and repair requirements, the dimensions of the four sizes are given in table 2.

TABLE 1

Nominal thread diameter mm	Width across flats mm	Annular bearing area Thread stress area *
5	8	1,08
6	10	1,44
8	13	1,23
10	15	0,90
	16	1,30
	17	1,73
12	18	0,91
	19	1,16
14	21	0,96
	22	1,24
16	24	1,02
20	30	0,95
24	36	0,86
30	46	1,02
36	55	1,04

* Calculation based on clearance holes ISO 273 (revised), medium series.

TABLE 2

Thread size <i>d</i>		M10	M12	M14
<i>P</i>	1)	1,5	1,75	2
<i>d_w</i>	min.	13,6	15,6	17,4
<i>e</i>	min.	16,64	18,90	21,10
<i>m</i>	max.	10	8,8	11,3
	min.	9,64	8,44	10,87
<i>m'</i>	min.	7,7	6,75	8,7
	max.	15	17	22
<i>s</i>	min.	14,73	16,73	18,67

1) *P* = pitch of the thread.

iTeh STANDARD PREVIEW
(standards.iteh.ai)

This page intentionally left blank

[ISO 4033:1979](#)

<https://standards.iteh.ai/catalog/standards/sist/177d1e1d-fcac-4a05-af2f-ed5946cba462/iso-4033-1979>

iTeh STANDARD PREVIEW
(standards.iteh.ai)

This page intentionally left blank

[ISO 4033:1979](#)

<https://standards.iteh.ai/catalog/standards/sist/177d1e1d-fcac-4a05-af2f-ed5946cba462/iso-4033-1979>