



Designation: C1795 – 17

Standard Test Methods for High-Temperature Characterization of Gypsum Boards and Panels¹

This standard is issued under the fixed designation C1795; the number immediately following the designation indicates the year of original adoption or, in the case of revision, the year of last revision. A number in parentheses indicates the year of last reapproval. A superscript epsilon (ϵ) indicates an editorial change since the last revision or reapproval.

1. Scope

1.1 These test methods describe three bench top test methods for measuring the thermophysical responses of gypsum boards and panels when exposed to high temperatures. The test methods are:

1.1.1 *High-temperature Core Cohesion*—This test method evaluates the ability of the test specimen to withstand a specified mechanical strain while exposed to elevated temperature.

1.1.2 *High-temperature Shrinkage*—This test method evaluates dimensional changes in the test specimen when exposed to elevated temperatures.

1.1.3 *High-temperature Thermal Insulation*—This test method evaluates the rate of heat transfer through the thickness of the test specimen by measuring the length of time required to heat the center of the test specimen over a specified temperature rise when exposed to prescribed furnace conditions.

1.2 The test methods appear in the following order:

Test Method	Section
High-temperature Core Cohesion	4
High-temperature Shrinkage	5
High-temperature Thermal Insulation	6

1.3 *Units*—The values stated in either inch-pound units or SI units (given in parenthesis) are to be regarded separately as standard. The values stated in each system may not be exact equivalents; therefore, each system shall be used independently of the other. Combining values from the two systems may result in non-conformance with the standard.

1.4 While these tests are useful for evaluating fire properties of gypsum boards and panels, they are not suitable for predicting the Test Methods E119 fire resistance performance of a specific gypsum protected assembly that has not previ-

ously been tested in accordance with Test Methods E119 and correlated to these tests.²

1.5 *This standard is used to measure and describe the response of materials, products, or assemblies to heat and flame under controlled conditions, but does not by itself incorporate all factors required for fire hazard or fire risk assessment of the materials, products, or assemblies under actual fire conditions.*

1.6 *This standard does not purport to address all of the safety concerns, if any, associated with its use. It is the responsibility of the user of this standard to establish appropriate safety and health practices and determine the applicability of regulatory limitations prior to use.*

1.7 *This international standard was developed in accordance with internationally recognized principles on standardization established in the Decision on Principles for the Development of International Standards, Guides and Recommendations issued by the World Trade Organization Technical Barriers to Trade (TBT) Committee.*

2. Referenced Documents

2.1 ASTM Standards:

- C11 Terminology Relating to Gypsum and Related Building Materials and Systems
- E119 Test Methods for Fire Tests of Building Construction and Materials
- E631 Terminology of Building Constructions

2.2 Other Standards:

- EN 520 Gypsum Plasterboards—Definitions, Requirements and Test Methods

3. Terminology

3.1 *General*—Refer to Terminologies C11 and E631 for standard terminology on gypsum and related building materials, systems and building construction.

3.2 Definitions of Terms Specific to This Standard:

² Shipp, P. H., and Yu, Q., “Thermophysical Characterization of Type X Special Fire Resistant Gypsum Board,” *Proceedings of the Fire and Materials 2011 Conference*, San Francisco, Jan. 1, 2011 – Feb. 2, 2011, Interscience Communications Ltd., London, UK, pp 417-426.

¹ This test method is under the jurisdiction of ASTM Committee C11 on Gypsum and Related Building Materials and Systems and is the direct responsibility of Subcommittee C11.01 on Specifications and Test Methods for Gypsum Products.

Current edition approved June 1, 2017. Published June 2017. Originally approved in 2005. Last previous edition approved in 2015 as C1795 – 15. DOI: 10.1520/C1795-17.

3.2.1 *Thermal Insulation Index (TI), n*—a single value index that denotes the rate of heating at the center of the Thermal Insulation Test specimen as determined by the elapsed time to the nearest minute for the temperature to rise from 104 to 392°F (40 to 200°C).

4. High-temperature Core Cohesion

4.1 *Summary of Test Method*—The high-temperature core cohesion of gypsum panel products is evaluated by applying a shear force and bending moment to a cantilevered test specimen by hanging a weight from the free end of the specimen. The specimen is exposed to heating from two burner flames at a specified distance and location from its fixed end. The exposure of the specimen to the burner flame results in the calcination of the specimen, which weakens the core matrix and results in deflection of the loaded, cantilevered specimen. When a specified deflection occurs, the specimen is examined for breakage. This test is derived from an earlier version of the high-temperature core cohesion test found in EN 520.

4.2 *Significance and Use*—This test method provides a procedure for evaluating the high temperature strain capacity of gypsum panel products.

4.3 Apparatus:

4.3.1 *Specimen Mounting Device*—A fixture capable of rigidly supporting the specimen and weight in the horizontal plane. The specimen is clamped or otherwise held rigidly at one end in a cantilevered horizontal position. The mounting fixture shall provide sufficient clearance of the end weight fixture above the horizontal base to allow for the full prescribed deflection of the specimen. (Figs. 1 and 2).

4.3.2 *Hanger Strap*—A bracket for suspending a weight from the free end of the test specimen consisting of an L-shaped metal strap constructed of 20 gauge sheet metal or other suitable material. The short leg of the strap is 0.65 ± 0.05 in. (16 ± 1 mm) in length. The long leg of the strap has

a mounting hole drilled in it near the outer extremity and is of sufficient length that the hook or wire by which the loading weight is suspended from the strap does not contact the specimen.

4.3.3 *Loading Weight*—A weight fitted with a hook or wire for hanging it from the free end of the specimen by means of the hanger strap. The loading weight may be configured as a cup or disk to receive weighted shot or slotted disks to adjust the weight for different test specimen thicknesses. The total weight of the entire loading device (hanger strap, loading weight, suspension wire or hook) shall correspond to the nominal thickness of the sample in accordance with Eq 1, rounded to the nearest integer multiple of 25, and shown in Table 1:

$$W = 10.6 \left(\frac{t}{0.50} \right) \tag{1}$$

Where:

W = Total weight of loading device, oz., and
t = Nominal board thickness, in.

TABLE 1 Required Loading Device Weight for Each Board Thickness

Nominal Board Thickness	Weight of Loading Device
½ in. (12.7 mm)	10.6 ± 0.4 oz (300 ± 10 g)
⅝ in. (15.9 mm)	13.2 ± 0.4 oz (375 ± 10 g)
¾ in. (19.1 mm)	15.9 ± 0.4 oz (450 ± 10 g)

4.3.4 *Platform*—An adjustable height platform to limit the deflection of the specimen to the specified distance of 0.4 ± 0.05 in. (10 ± 1 mm) (See Fig. 1.)

4.3.5 *Heating System:*

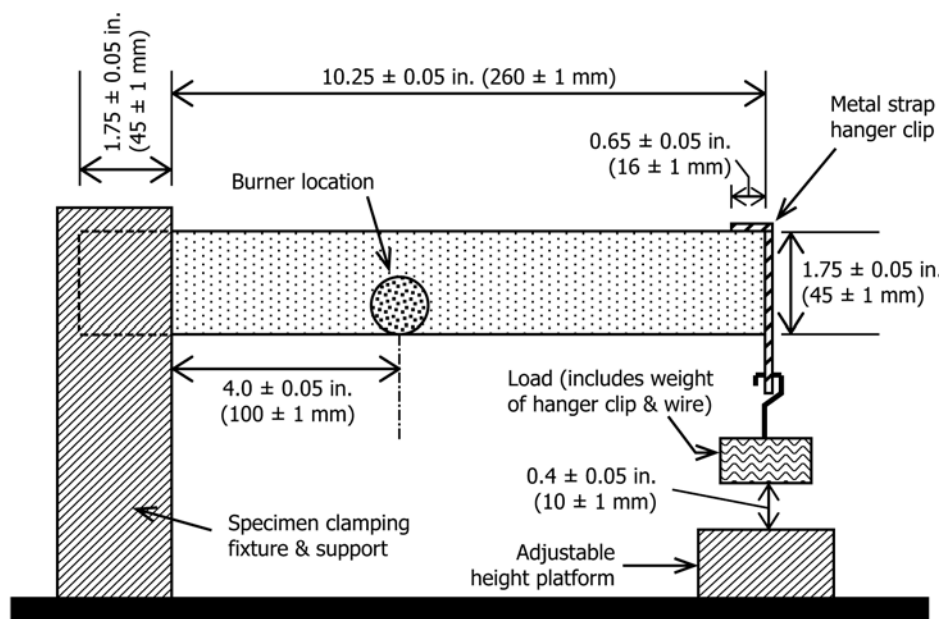

FIG. 1 Side View of Core Cohesion Test Apparatus

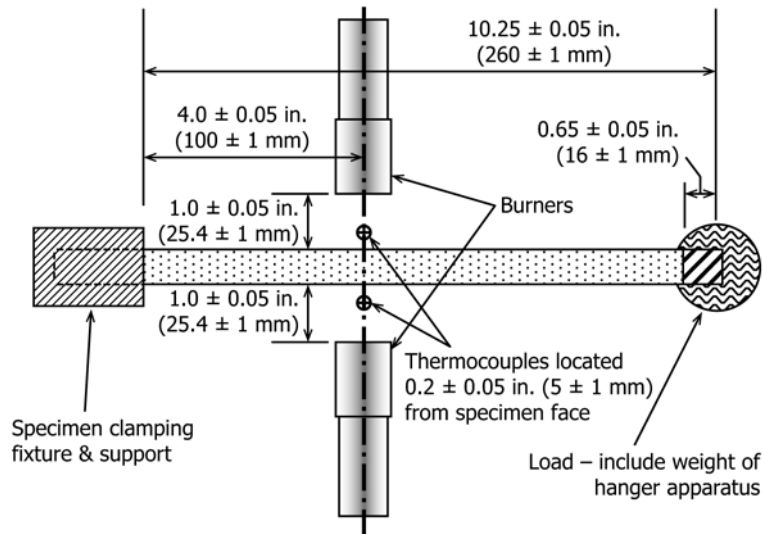

FIG. 2 Top View of Core Cohesion Test Apparatus

4.3.5.1 Two propane Meker burners having a nozzle diameter of 1.14 ± 0.04 in. (29 ± 1.0 mm) and a gas orifice of 0.03 ± 0.01 in. (0.76 ± 0.25 mm) are mounted horizontally with their nozzles facing each other (Figs. 2 and 3).

4.3.5.2 The axes of the burners are aligned to within 0.05 in. (1 mm).

4.3.5.3 Needle valves at the base of each burner provide for fine adjustment of the gas flow rate to control flame shape and temperature.

4.3.5.4 Natural gas or propane is supplied to each burner from a single source via a tube with a Y fitting. A pressure regulator to control the pressure and a pressure gauge to measure the pressure are installed in the line between the source and the Y fitting. The gas pressure supplied to the Y

fitting shall be 0.5 ± 0.1 psig (3.5 ± 0.7 kPa). A flow meter may optionally be installed to aid in monitoring and maintaining consistent gas flow rates (Fig. 4).

4.3.5.5 The burners are adjusted to produce stable, premixed flames with the characteristic blue zone of the flame covering the entire screen area at the mouth of the burner and projecting $\frac{3}{8} \pm \frac{1}{8}$ in. (10 ± 3 mm) from the burner. Beyond the blue premixed zone, both flames project horizontally in a turbulent deflagration contacting the specimen near its bottom edge with little or no vertical deflection due to buoyancy or forced convection in the space between the burner and where the flame strikes the test specimen perpendicularly. The zone of heating extends from the bottom edge of the specimen upwards to the top edge.

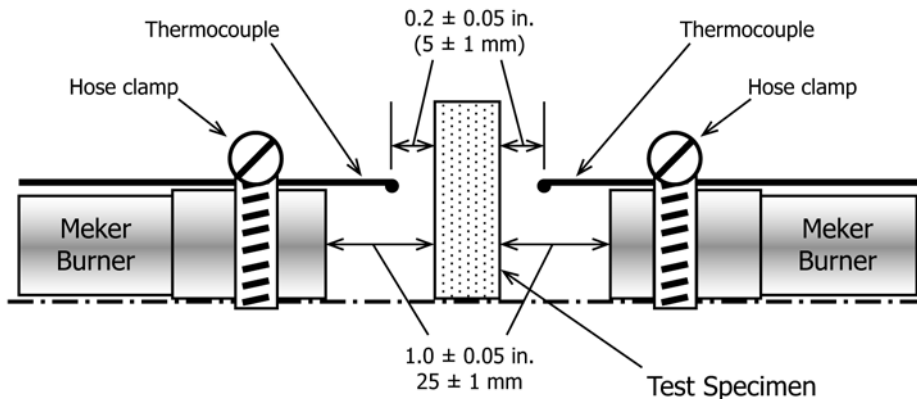

FIG. 3 Alignment of Burners and Thermocouples with Respect to Test Specimen

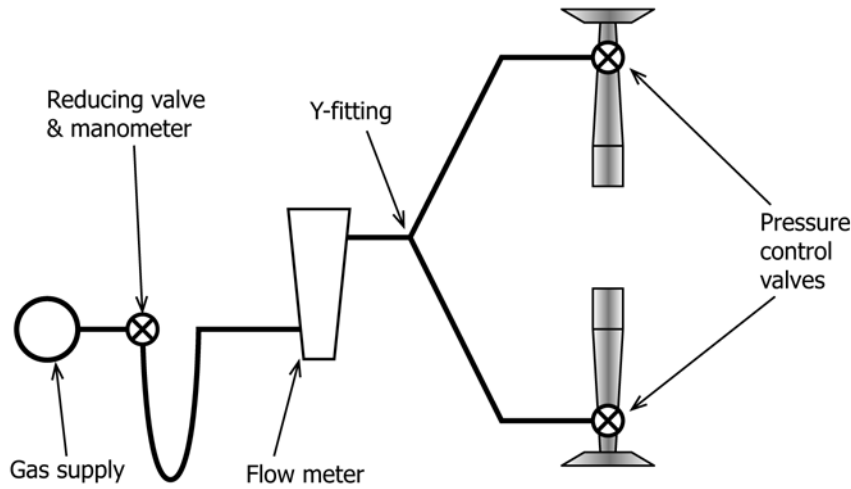

FIG. 4 Schematic of Gas Supply to Burners

4.3.6 *Thermocouples*—Insulated chromel-alumel thermocouples (Type K) $\frac{1}{16}$ in. (1.6 mm) diameter stainless steel sheathed, ungrounded tip 36 ga.

4.3.6.1 The thermocouples are aligned horizontally with the top of the burners and secured to the burner with a hose clamp (Fig. 3).

4.3.7 *Gauge Blocks*, 0.2 in. (5 mm), 0.4 in. (10 mm), and 1.0 in. (25.4 mm).

4.3.8 *Stopwatch*—Timing device capable of measuring elapsed time in one second intervals or less.

4.4 *Sampling*—Test specimens shall be taken from the sample lot of gypsum panel products as indicated in 4.5.

4.5 *Test Specimens:*

4.5.1 Cut six specimens from the gypsum board sample using a saw to insure straight, square edges.

4.5.2 Each specimen shall be 12.0 ± 0.1 in. (300 ± 2 mm) long by 1.75 ± 0.05 in. (45 ± 1 mm) wide, with the edges of the specimen not less than 4 in. (100 mm) from any edge of the full gypsum board sample. Specimens can be tested when cut from any orientation from the sample board for specific evaluation but since the orientation can contribute to the measured results, the orientation must be identified and recorded for each test result. Common orientations for evaluation are the long edge of the specimen parallel to the paper-bound or long edge of the board as manufactured or the long edge of the specimen parallel to the end perpendicular to the paper-bound or long edge of the board as manufactured.

4.6 *Conditioning*—Condition specimens to constant weight at a temperature of $85 \pm 15^\circ\text{F}$ ($29.5 \pm 8.5^\circ\text{C}$) and relative humidity $50 \pm 2\%$.

4.7 *Procedure:*

4.7.1 Clamp one end of the test specimen in the supporting device in a cantilever configuration. The long edge extends lengthwise 10.25 ± 0.05 in. (260 ± 1 mm) from the support point to the free end of the test specimen. The short edge of the test specimen is vertical (Figs. 1-3).

4.7.2 Align the lower edge of the test specimen to the lowest point of the burner nozzles (Figs. 1 and 3).

4.7.3 Position the mid-point of the burner nozzles 4.0 ± 0.05 in. (100 ± 1 mm) from the point of support (Figs. 1 and 2).

4.7.4 Position the mouth of each burner nozzle 1.0 ± 0.05 in. (25.4 ± 1 mm) from the adjacent specimen face by means of a gauge block (Figs. 2 and 3).

4.7.5 Position each thermocouple parallel to the upper edge of the burner and 0.2 ± 0.05 in. (5 ± 1 mm) from the specimen face by means of a gauge block (Figs. 2 and 3).

4.7.6 Place the hanger strap on the free end of the cantilevered test specimen, 10.25 ± 0.05 in. (260 ± 1 mm) from the support point of the mounting device, and suspend the loading weight from it. The total weight of the suspended load shall be as specified in 4.3.3.

4.7.7 Adjust the height of the platform so that the distance from the platform to the bottom of the suspended load is 0.4 ± 0.05 in. (10 ± 1 mm) above the surface of the platform. Verify the spacing by means of a gauge block (Fig. 2).

4.7.8 Open the gas valve, start the stopwatch and ignite both burners.

4.7.8.1 Adjust the gas flow so that the temperature at each thermocouple is $1832 \pm 90^\circ\text{F}$ ($1000 \pm 50^\circ\text{C}$).

4.7.8.2 Both flames shall be stabilized at the specified temperature with the characteristic appearance described in 4.3.5.5 within 60 s of lighting the burners.

4.7.9 The test is over when the specimen deflects downward and the load comes into contact with the surface of the platform.

4.7.9.1 At the conclusion of the test, stop the stopwatch and shut off the burners.

4.7.9.2 Visually inspect the specimen immediately after shutting off the burners.

4.7.9.3 Observe if the specimen has broken into two or more distinct pieces at or before the time at which the load contacted the platform.

4.7.9.4 Record the elapsed time from the start to the end of the test and whether or not the specimen was broken into two or more distinct pieces.