



Designation: F 1592 – 01

Standard Test Methods for Detention Hollow Metal Vision Systems¹

This standard is issued under the fixed designation F 1592; the number immediately following the designation indicates the year of original adoption or, in the case of revision, the year of last revision. A number in parentheses indicates the year of last approval. A superscript epsilon (ϵ) indicates an editorial change since the last revision or reapproval.

1. Scope

1.1 These test methods cover fixed detention hollow metal vision systems of various materials and types of construction. These fixed hollow metal vision systems are used in wall openings in detention and correctional institutions designed to incarcerate inmates.

1.2 Frame assemblies investigated under these test methods include individual components including detention security hollow metal frames, frame anchoring, security glazing, panels, and removable glazing stops.

1.3 These test methods are designed to test the capability of a fixed detention hollow metal vision system to prevent, delay, and frustrate escape; to limit or control access to unauthorized or secured areas; and prevent passage of contraband.

1.4 These test methods apply primarily to detention hollow metal vision systems between secure areas generally found inside a detention/correctional facility such as: day rooms, control rooms, cells, and sally ports. These test methods are applicable to vision systems other than hollow metal, provided testing and reporting procedures are followed.

1.5 The values stated in inch-pound units are to be regarded as the standard. The values given in parentheses are for information only.

1.6 *This standard does not purport to address all of the safety concerns, if any, associated with its use. It is the responsibility of the user of this standard to establish appropriate safety and health practices and determine the applicability of regulatory limitations prior to use.*

2. Referenced Documents

2.1 ASTM Standards:

E 2074 Test Method for Fire Tests of Door Assemblies, Including Positive Pressure Testing of Side-Hinged and Pivoted Swinging Door Assemblies²

2.2 NAAMM/HMMA Standard:³

ANSI/HMMA 863-98 Guide Specifications for Detention

Security Hollow Metal Doors and Frames

2.3 NFPA Standard:⁴

252 Methods of Fire Tests of Door Assemblies

2.4 UL Standards:⁵

UL-10 (C) Fire Tests of Door Assemblies

UL-752 Bullet Resisting Equipment

3. Terminology

3.1 Definitions of Terms Specific to This Standard:

3.1.1 *borrowed light, n*—a fixed window frame for use in an interior partition.

3.1.1.1 *Discussion*—This term is derived from the concept of borrowing light from one room or space to help illuminate another.

3.1.2 *butt joint, n*—the corner or mullion joint of a frame in which the stop of either member is notched to fit the other, resulting in a perpendicular joint.

3.1.3 *component, n*—a subassembly, as distinguished from a part, that combines with other components to make up a total frame assembly.

3.1.3.1 *Discussion*—The prime components of a fixed vision system assembly are frame, wall, glazing, and panels.

3.1.4 *contraband breach, n*—any through opening created such that a 0.060-in.-diameter wire can be passed completely through the assembly at any location constitutes a contraband breach.

3.1.5 *detention security, n*—ensurance of the restriction of mobility of inmates to designated areas within a correctional or detention facility.

3.1.6 *forcible egress, n*—the ability to pass a 5 × 8 × 8-in. rigid rectangular box through an opening in the test sample created by destructive testing procedures.

3.1.7 *glazing stop, n*—a formed metal section used to secure glazing or panel in a frame either by application to the glazing material or as an integral part of the frame.

3.1.8 *head or header, n*—the horizontal member that forms the top of a frame.

3.1.9 *hollow metal, n*—a term used in reference to such items as doors, frames, partitions, enclosures, and other items that are fabricated from metal sheet, usually carbon steel.

¹ These test methods are under the jurisdiction of ASTM Committee F33 on Detention and Correctional Facilities and are the direct responsibility of Subcommittee F33.02 on Physical Barriers.

Current edition approved Dec. 10, 2001. Published January 2002. Originally published as F 1592 – 95. Last previous edition F 1592 – 95.

² *Annual Book of ASTM Standards*, Vol 04.07.

³ Available from Hollow Metal Manufacturer's Association, A Division of NAAMM, 600 S. Federal St., Chicago, IL 60605.

⁴ Available from National Fire Protection Association, Batterymarch Park, Quincy, MA 02269.

⁵ Available from Underwriters Laboratories, 333 Pfingsten Road, Northbrook, IL 60062.

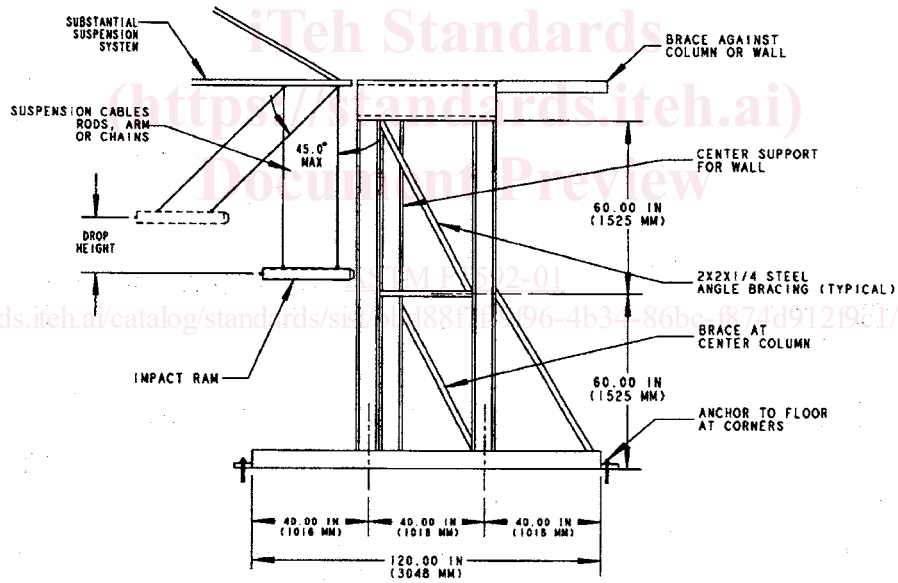
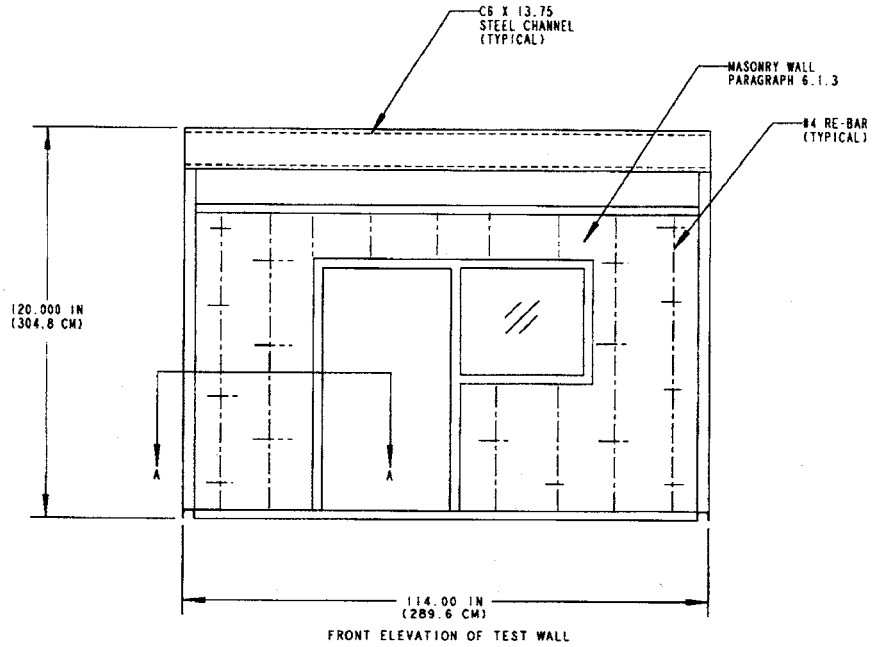

FIG. 1 a Test Wall Detention Hollow Metal Vision Systems

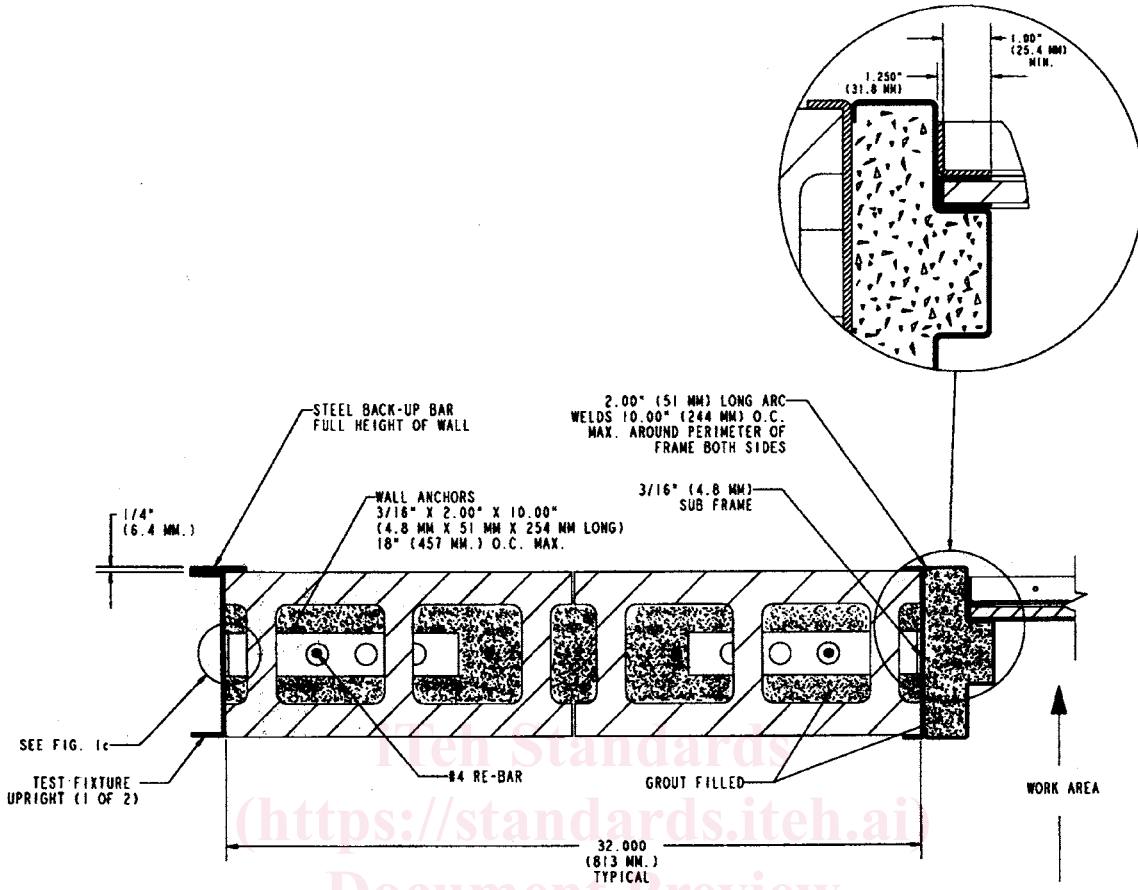

FIG. 1 b Section A-A (continued)

ASTM F1592-01
<https://standards.iteh.ai/catalog/standards/sist/bbd88f7f-9f96-4b34-86bc-f874d912f9c1/astm-f1592-01>

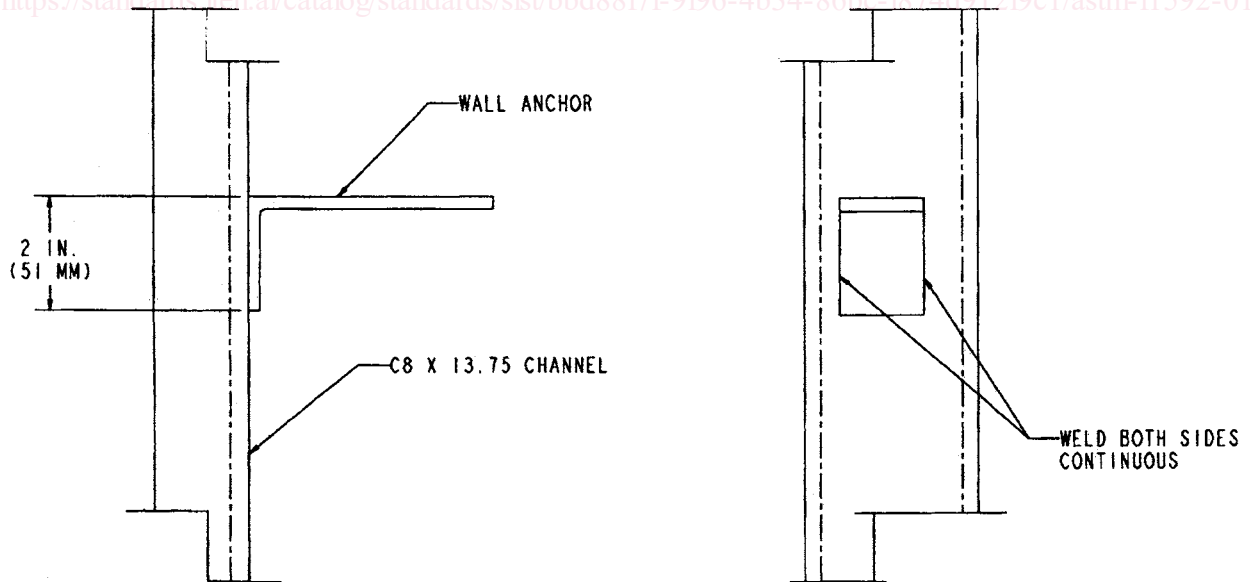

FIG. 1 c Wall Anchor Welding Detention Hollow Metal Vision Systems (continued)

3.1.9.1 Discussion—These products are usually internally reinforced but hollow, hence the term hollow metal. In doors

and partitions, the voids are normally filled with insulation. In frames, the jambs and sometimes heads are grouted where

installed in masonry walls, or of such construction that they may be left hollow⁶ (see ANSI/HMMA 863-98).

3.1.10 *jamb, n*—the vertical member forming the side of a frame.

3.1.11 *miter joint, n*—the corner joint of a head and jamb in which the trim faces, and sometimes the stops, meet at an angle (usually 45°).

3.1.11.1 *Discussion*—The miter joint can be either punched in the flat form or sawed after the members are formed.

3.1.12 *mullion, n*—a vertical or horizontal member within a frame, separating either doors, a door and a sidelight, glazed areas, or panels.

3.1.13 *multi-light, n*—two or more fixed lights or glazing, located adjacent to each other, horizontally, vertically, or both within the same frame, either located in an interior partition or in an exterior wall.

3.1.14 *panel, n*—for the purposes of these test methods, the *panel* is a steel plate at least 0.375 in. thick, installed to transfer impact energy to the glazing stops and the assembly.

3.1.15 *performance characteristic, n*—the response of the assembly or its components to any one of the tests described herein.

3.1.16 *sidelight, n*—a fixed light of glazing located adjacent to a door or doors within the same frame.

3.1.17 *sill, n*—the bottom horizontal member of a frame.

3.1.18 *tamper-resistant security screw, n*—a screw that is designed to be removed only by special tools kept by detention/correctional facility maintenance personnel.

3.1.18.1 *Discussion*—The screws should be resistant to removal by means other than use of the appropriate special tool. In some cases, tamper-resistant security screws are furnished with twist-off heads such that a means of removal after final installation is not provided. Regarding impact resistance, the frame manufacturer may choose various grades (strengths) and sizes of tamper-resistant screws, and may install them at various spacings to obtain satisfactory test results. All information regarding the tamper-resistant security screws used by the manufacturer shall be provided as part of test reports.

3.1.19 *test completion, n*—conduct of one test sequence for each of the frame assemblies.

3.1.20 *testing laboratory, n*—an independent materials testing laboratory not associated with the manufacturer.

3.1.21 *vision system, n*—hollow metal frame with glazing, glazing stops, and panels in place ready for service.

3.1.21.1 *Discussion*—A *vision system* may be a borrowed light or sidelight.

3.1.22 *vision system frame, n*—an assembly of members surrounding and supporting glazing panels, steel panels, or combinations thereof, located either in an interior partition or exterior wall.

3.1.22.1 *Discussion*—If an exterior application is desired, other standards that address cutting and deflection may be applicable.

4. Significance and Use

4.1 A major concern for corrections administration officials is the resistance of security barriers used in detention/correctional facilities to certain types of physical attack that it is reasonable to expect in the field. These test methods are designed to aid in identifying a level of physical security for fixed detention hollow metal vision systems.

4.2 These test methods are not intended to provide a measure of resistance for a vision system subjected to attack by corrosive agents, high-powered rifles, explosives, sawing, or other such methods. These test methods are intended to evaluate the resistance of a vision system to violent attacks using battering devices such as benches, bunks, fire extinguishers, or tables; hand guns up to and including the .44 magnum; and fires started by using mattresses, books, and similar flammable materials.

4.3 The primary purpose or result of this standard is to provide detailed test methods that approximate the levels of abuse to which it is possible that vision systems become subjected in the field. The desired result of its use is to give assurance of protection to the public, to prison administrative personnel, and to the inmates themselves in the event of such attack.

NOTE 1—It is recommended that detention/correctional facility administration provide adequate training, supervision and preventive maintenance programs to enable hollow metal vision systems to function as intended throughout the expected service life.

5. Sampling

5.1 Sample frame assemblies shall be representative of the types and styles intended for use in the application outlined in 1.4.

5.2 The manufacturer shall permanently mark the test samples and retain them at the manufacturing facility for future reference. As an alternative to retaining test samples, the manufacturer shall contract with the testing laboratory to provide a certified procedure for the construction of tested assemblies with factory follow-up inspection service as an option (see 8.2).

5.3 Test reports shall include complete details of test assemblies, details or photographs of the testing apparatus, or both, and installation instructions including templates for all items of hardware (see 8.3).

5.4 In the event of failure in one or more of the performance tests, the manufacturer shall provide another complete test sample with test wall where applicable.

6. Specimen Preparation

6.1 Construction:

6.1.1 The construction and size of the sample vision system assemblies shall be representative of the application under investigation and shall include the multilight (borrowed light) and sidelight configurations (see Fig. 2 and Fig. 3).

6.1.2 The vision system assembly support fixture shall simulate the rigidity normally provided to a vision system in a building by the ceiling, floor, and walls. Fig. 1 shows an acceptance fixture.

6.1.3 *Description of the Test Wall*—The test fixture for the vision system shall include a vertical masonry wall section

⁶ See The Hollow Metal Manual-87, available from the Hollow Metal Manufacturer's Association, A Division of NAAMM, 600 S. Federal St., Chicago, IL 60605.

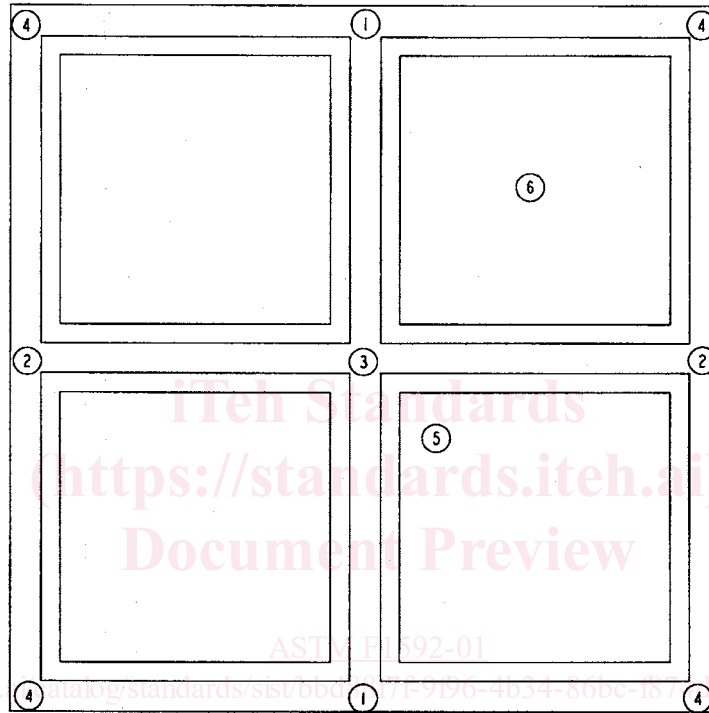
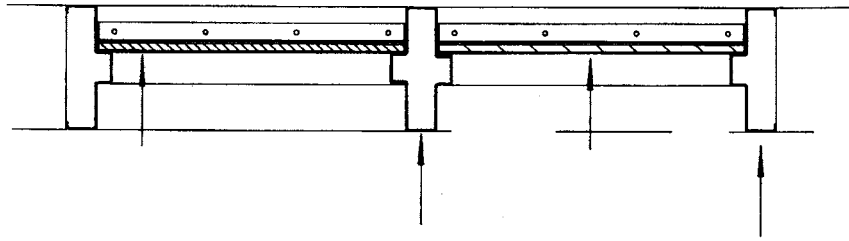

FIG. 2 Test Assembly Elevation Location of Strike Points Described in Table 1

constructed suitably to retain the sample throughout the testing procedure. The wall specification shall be included as part of the test report.

6.2 *Mounting for Testing:*

6.2.1 The vision system sample shall be mounted such that the removable glazing stops are mounted on the side of the glazing or panel opposite the impact test ram. In this test configuration, the removable glazing stops and screws must prevent the glazing or panel from being forced out of the opening by ram impacts.

6.2.2 Install components such as frames, glazing or panels, and glazing stops in the component test fixture as described in 6.1. Provide clearances around glazing or panels and install sealant or gasketing in accordance with the manufacturer's recommendations. Manufacturer's recommendations and instructions shall be included as part of test reports.

7. Test Methods

7.1 *Bullet Penetration:*

7.1.1 When specified by the contract documents of a detention/correctional facility project, test the vision system assemblies for bullet penetration in accordance with UL-752.

7.1.2 Testing of the frame, security glazing, or panels as individual components is acceptable if conducted in accordance with UL-752. The level of performance shall meet the rating of Level 3: .44 magnum.

7.1.3 Pass/fail criteria for bullet penetration shall be in accordance with UL-752.

7.1.4 *Precision and Bias*—No statement is made about either the precision or bias of the bullet penetration test method in these test methods since the result merely states whether there is conformance to the criteria for success specified in the procedure.

7.2 *Vision System Impact Test:*

7.2.1 *Scope*—This test method is designed to evaluate the capability of a hollow metal vision system including frame, glazing/panels, and wall anchoring to resist repetitive impact forces at the designated critical areas.

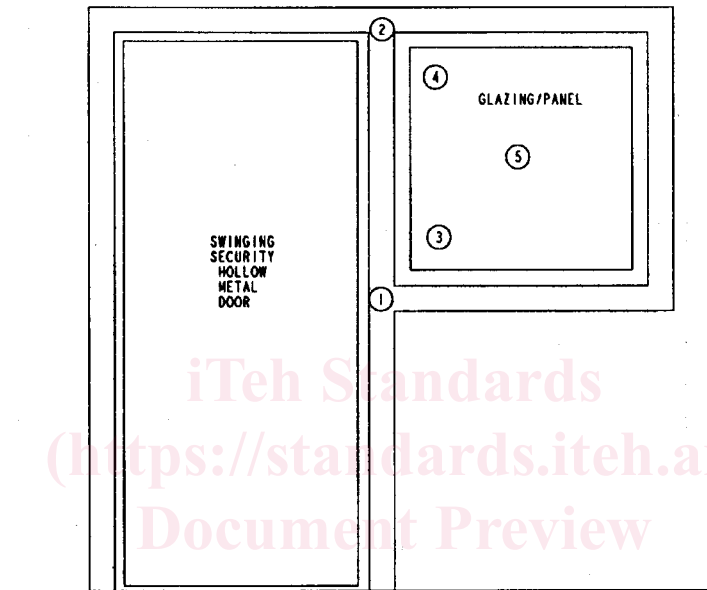
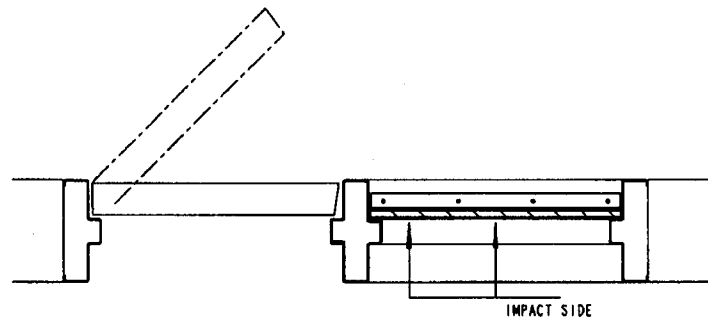

FIG. 3 Test Assembly Elevation Location of Strike Points Described in Table 2

7.2.2 Significance and Use:

7.2.2.1 This test method is intended to closely simulate a sustained battering ram-style attack and provide an evaluation of the capability of the assembly to prevent, delay, and frustrate escape or access to unauthorized areas. The test results may be used to aid in identifying a level of physical security for various configurations of detention hollow metal vision systems.

7.2.2.2 An impact test of this design performed on a complete assembly evaluates the impact fatigue strength of the assembly and its components as well as quality of fabrication techniques and strengths of materials used.

7.2.3 Apparatus:

7.2.3.1 *Impact Ram*—The impact ram shall be a pendulum system with a steel weight capable of delivering horizontal impacts of up to 200 ft · lbf (271.2 J). The weight of the ram may vary from 80 lb (36.0 kg). The striking nose of the ram shall be made from C1010–1020 carbon steel, the striking surface area of which shall be $4 \pm 0.04 \text{ in.}^2$ (25.8 cm²) (see Fig. 5).

7.2.4 Procedure:

7.2.4.1 With the test fixture and test apparatus, deliver the series of impacts listed in Table 1 (see Fig. 2) and Table 2 (see Fig. 3) to the assembly opposite the glazing stop side of the glazing/panel.

7.2.4.2 The manufacturer may elect to test the frame without panels or glazing installed in accordance with the frame series of impact sequences shown in Table 1 and Table 2. If so, test reporting in accordance with 8.3 shall reflect this approach.

7.2.4.3 The security glazing and panels shall remain in place and the frame shall meet criteria described in 7.2.4.4 and 7.2.4.5 throughout the testing procedure. The glazing, panels, glazing stop, or frame that is damaged to the extent that forcible egress can be achieved constitutes failure.

7.2.4.4 If impact testing is performed on the frame without glazing or panels installed, photograph and document the damage to frame joints and sections (see 8.3.8). If any weld joints completely separate, or the entire frame joint separates completely during testing, the sample will be judged to have failed the impact test.

7.2.4.5 Whether the frame is tested with or without glazing and panels, the wall anchoring shall retain the frame in place throughout the test procedure. If one or more anchors break