



Designation: **C1523—10 C1523 – 17**

Standard Test Method for Determining Modulus, Tear and Adhesion Properties of Precured Elastomeric Joint Sealants¹

This standard is issued under the fixed designation C1523; the number immediately following the designation indicates the year of original adoption or, in the case of revision, the year of last revision. A number in parentheses indicates the year of last reapproval. A superscript epsilon (ϵ) indicates an editorial change since the last revision or reapproval.

1. Scope

1.1 This test method describes a laboratory procedure for measuring modulus, tear, joint movement ability and adhesion properties of applied, Precured Elastomeric Joint Sealants, hereinafter referred to as “applied seal” and if not applied, hereinafter referred to as “seal,” on portland cement mortar as a standard substrate and or other substrates. It tests these properties after dry, wet, frozen, heat aged or artificially weather-aged conditionings, or both.

1.2 The values stated in SI units are to be regarded as the standard. The values given in parentheses are provided for information only.

1.3 *This standard does not purport to address all of the safety concerns, if any, associated with its use. It is the responsibility of the user of this standard to establish appropriate safety and health practices and determine the applicability of regulatory limitations prior to use.*

1.4 The committee with jurisdiction over this standard is not aware of any similar standard published by another committee or organization.

1.5 *This international standard was developed in accordance with internationally recognized principles on standardization established in the Decision on Principles for the Development of International Standards, Guides and Recommendations issued by the World Trade Organization Technical Barriers to Trade (TBT) Committee.*

2. Referenced Documents

2.1 *ASTM Standards:*²

[C717 Terminology of Building Seals and Sealants](#)

[C1375 Guide for Substrates Used in Testing Building Seals and Sealants](#)

[C1442 Practice for Conducting Tests on Sealants Using Artificial Weathering Apparatus](#)

[D1566 Terminology Relating to Rubber](#)

[G113 Terminology Relating to Natural and Artificial Weathering Tests of Nonmetallic Materials](#)

[G151 Practice for Exposing Nonmetallic Materials in Accelerated Test Devices that Use Laboratory Light Sources](#)

[G154 Practice for Operating Fluorescent Ultraviolet \(UV\) Lamp Apparatus for Exposure of Nonmetallic Materials](#)

[G155 Practice for Operating Xenon Arc Light Apparatus for Exposure of Non-Metallic Materials](#)

3. Terminology

3.1 *Definitions*—Refer to Terminology [C717](#) for definitions of the following terms used in this test method: adhesive failure, cohesive failure, primer, modulus, and standard conditions and to Terminology [D1566](#) for tear and to Terminology [G113](#) for definitions related to artificial weathering.

4. Summary of Test Method

4.1 Model joints are prepared, the seal is adhered to the substrate utilizing an adhesive sealant specified by the manufacturer, hereinafter referred to as adhesive, then exposed to a variety of conditionings such as heat, cold, artificial weathering or water immersion. A specific set of specimens can go through each conditioning or separate specimens can be used for each conditioning. After exposure the test specimens are subjected to an elongation (strain) and held at this elongation for as long as is desired. The

¹ This test method is under the jurisdiction of ASTM Committee [C24](#) on Building Seals and Sealants and is the direct responsibility of Subcommittee [C24.30](#) on Adhesion. Current edition approved ~~March 1, 2010~~ June 1, 2017. Published ~~March 2010~~ June 2017. Originally approved in 2002. Last previous approved in ~~2004~~ 2010 as C1523–04–10. DOI: ~~10.1520/C1523-10~~ 10.1520/C1523-17.

² For referenced ASTM standards, visit the ASTM website, www.astm.org, or contact ASTM Customer Service at service@astm.org. For *Annual Book of ASTM Standards* volume information, refer to the standard's Document Summary page on the ASTM website.

elongation (joint expansion) is performed with a tensometer to obtain tensile-forces during the pull. One aspect of the test has the applied seal cut in the middle of the joint and then elongated and the degree of tear propagation noted. After the initial strain the samples can be subjected to cycles of repeated strain. The samples can also be tested to destruction. The movement test and tear test can be done on separate sets of test specimens or done sequentially with the same test specimen.

5. Significance and Use

5.1 Seals are manufactured in flat extruded shapes and are primarily used to span joint openings. The seal is adhered to construction substrates utilizing a liquid applied adhesive, to seal building openings such as panel joints, metal flashing joints or other joints in place of conventional liquid applied sealants. In actual use, failure of an applied seal in an active joint is usually manifested by cohesive failure of the seal; adhesive failure between the adhesive and the substrate; adhesive failure between the adhesive and the seal; cohesive failure of the substrate or tear propagation parallel to the joint length.

5.2 This test method can be used for testing the adhesion of the adhesive to the substrate and to the seal, tensile load at various strains and tear resistance at various strains after the specimens are exposed to wet, cold, hot and artificial weathering conditionings. All or some of these properties are experienced on actual job sites.

6. Apparatus and Materials

6.1 *Tensile Testing Machine*, capable of producing a tensile load on the specimen at a rate of 50 ± 5 mm (2.0 ± 0.20 in.)/min., and with a recording chart to show load strain values (tensile modulus).

6.1.1 *Fixed Member*—A fixed or essentially stationary member carrying one grip.

6.1.2 *Movable Member*—A movable member carrying one grip.

6.1.3 *Grips*—The grips should be suitable to firmly grasp the test fixture that holds the test specimen.

6.1.4 *Grip Fixture*—A fixture capable of being held by the grips and furnishing a tensile force to the sealant specimen.

6.2 *Spatulas*, for use in applying the adhesive.

6.3 *Caulking Gun*, for extruding adhesive from cartridges.

6.4 *Primer*, if applicable.

6.5 *Adhesive*.

6.6 *Seal*.

6.7 *Spacer*—Pieces of rigid material that help to maintain a joint opening of 12 mm (0.5 in.) while preparing the test specimen.

6.8 *Substrates*—2 substrate samples are required for each test specimen. The substrate sample size shall be determined by the size of the test machine grips, yet they must be of a size to allow the application of a 50 ± 5 mm (2 ± 0.2 in.) long seal.

6.9 *Freezer*, $-18 \pm 2^\circ\text{C}$ ($0 \pm 3.6^\circ\text{F}$).

6.10 *Oven*, $70 \pm 2^\circ\text{C}$ ($158 \pm 3.6^\circ\text{F}$).

6.11 *Apparatus*, in accordance with Practice G151 and G154, or G155 and C1442.

6.12 *Stencil Knife*, or similar instrument (5 mm cutting width).

7. Test Specimen

7.1 The standard joint configuration used in this test method shall be the bridge joint application as shown in Fig. 1.

NOTE 1—Other joint configurations such as beveled bridge joint application and/or U-joint application in place or in addition to the standard joint configuration may be specified for the test with the seal sample. While the beveled bridge joint application (Fig. 2) is similar in function and the calculation

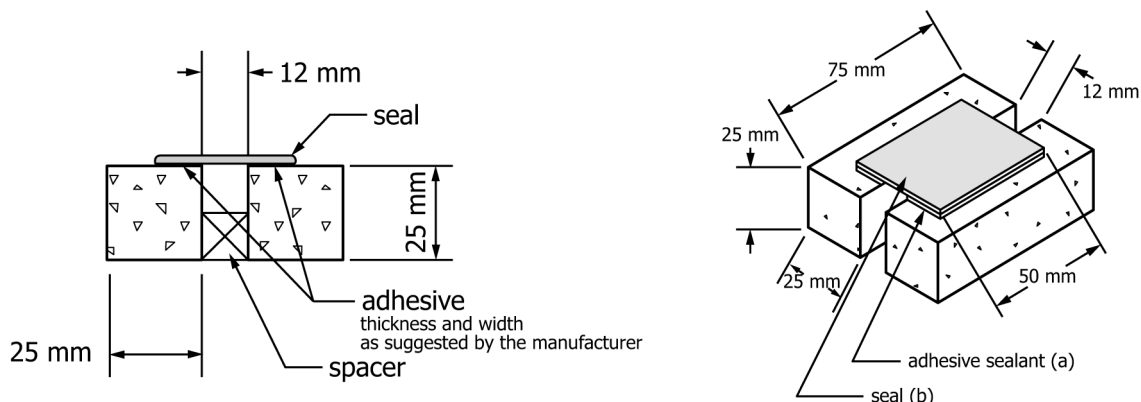

FIG. 1 Standard Substrate Test Specimen Assemblies

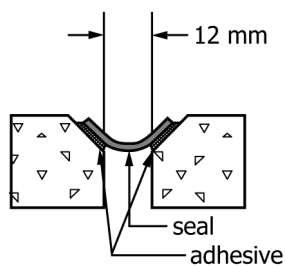

FIG. 2 Beveled Bridge Joint Configuration

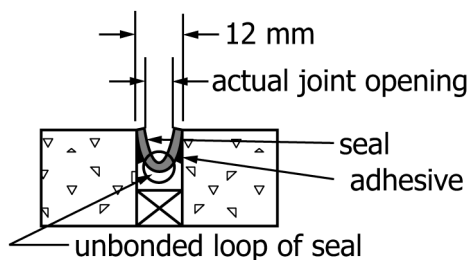

FIG. 3 U-joint Configuration

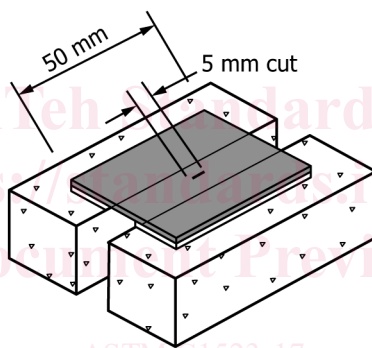

FIG. 4 Test Specimen Showing 5 mm Cut in the Middle of the Seal for Tear Propagation Testing

of test values to the standard joint configuration, different considerations have to be taken into account with the U-joint application (Fig. 3): (1) The actual joint opening of 12 mm (0.5 in.) will be reduced by the thickness of the seal and the adhesive, and (2) The size of the unbonded loop of the seal determines to a great extent the flexibility and expandability of the seal (Fig. 3).

7.2 Two substrate samples are required for each test specimen assembly as shown in Fig. 1.

7.2.1 *Initial Joint Opening (Width)*—Standard opening (width) for this test is 12 mm (0.5 in.).

NOTE 2—Joint openings other than the standard width may be specified for the test with the seal sample.

7.2.2 *Length of Applied Seal*—Standard length for this test is 50 mm (2 in.).

7.3 The standard substrate used in this test method shall be portland cement mortar.

NOTE 3—Other substrates such as EIFS, brick, wood, aluminum, plastic, metal or other in place or in addition to the standard substrate may be specified for the test with the seal sample. Any substrate other than the standard substrate has to be sized to fit the testing equipment.

7.3.1 *Mortar Block*—Prepare mortar blocks according to Section 7 of Guide C1375.

7.4 *Preparation of Test Specimen*—Condition substrates, adhesive, (and primer if needed) and seal for at least 24 h at standard conditions. Prime the substrate surface if required. Apply the adhesive at a specified thickness and width according to the manufacturers suggestion on the surface of the substrate, next to the joint opening and apply the seal into the wet adhesive according to the manufacturers suggestion while maintaining a joint opening of 12 mm (0.5 in.) as shown in Fig. 1.

NOTE 4—Care must be taken to bring the adhesive neatly to the edge of the test block and extra adhesive should be cleaned of the bridging section of the seal.

NOTE 5—Three test specimen assemblies per condition should be prepared for each substrate and each desired test(s) (Modulus/Adhesion or Tear, or both). It may be beneficial to prepare three extra specimen assemblies in the event one or more samples are unusable.