International Standard



4035

INTERNATIONAL ORGANIZATION FOR STANDARDIZATION • МЕЖДУНАРОДНАЯ ОРГАНИЗАЦИЯ ПО СТАНДАРТИЗАЦИИ • ORGANISATION INTERNATIONALE DE NORMALISATION

Hexagon thin nuts (chamfered) — Product grades A and B

Écrous bas hexagonaux (chanfreinés) — Grades A et B

Second edition — 1986-12-01

iTeh STANDARD PREVIEW
(standards.iteh.ai)

[ISO 4035:1986](https://standards.iteh.ai/catalog/standards/sist/c7b6b72b-3fd2-4fd5-8556-3f3ca4404ccd/iso-4035-1986)

<https://standards.iteh.ai/catalog/standards/sist/c7b6b72b-3fd2-4fd5-8556-3f3ca4404ccd/iso-4035-1986>



UDC 621.882.31

Ref. No. ISO 4035-1986 (E)

Descriptors : fasteners, nuts (fasteners), hexagonal nuts, specifications, dimensions, designation.

Foreword

ISO (the International Organization for Standardization) is a worldwide federation of national standards bodies (ISO member bodies). The work of preparing International Standards is normally carried out through ISO technical committees. Each member body interested in a subject for which a technical committee has been established has the right to be represented on that committee. International organizations, governmental and non-governmental, in liaison with ISO, also take part in the work.

Draft International Standards adopted by the technical committees are circulated to the member bodies for approval before their acceptance as International Standards by the ISO Council. They are approved in accordance with ISO procedures requiring at least 75 % approval by the member bodies voting.

International Standard ISO 4035 was prepared by Technical Committee ISO/TC 2, *Fasteners*.

iTeh STANDARD PREVIEW
(standards.iteh.ai)

This second edition cancels and replaces the first edition (ISO 4035:1979), of which it constitutes a technical revision.

<https://standards.iteh.ai/catalog/standards/sist/c7b6b72b-3fd2-4fd5-8556-3f3ca4404ccd/iso-4035-1986>

Users should note that all International Standards undergo revision from time to time and that any reference made herein to any other International Standard implies its latest edition, unless otherwise stated.

Hexagon thin nuts (chamfered) — Product grades A and B

0 Introduction

This International Standard is part of the complete ISO product standard series on hexagon drive fasteners. The series comprises:

- a) hexagon head bolts (ISO 4014, ISO 4015, ISO 4016 and ISO 8765);
- b) hexagon head screws (ISO 4017, ISO 4018 and ISO 8676);
- c) hexagon nuts (ISO 4032, ISO 4033, ISO 4034, ISO 4035, ISO 4036, ISO 8673, ISO 8674 and ISO 8675);
- d) hexagon flange bolts (ISO 4162, ISO 8100, ISO 8102 and ISO 8104);
- e) hexagon flange screws;¹⁾
- f) hexagon flange nuts (ISO 4161, ISO 7043 and ISO 7044);
- g) structural bolting (ISO 4775 and ISO 7411 to ISO 7417).

1 Scope and field of application

This International Standard gives specifications for chamfered hexagon thin nuts, with thread diameters from M1,6 to M64 inclusive, with product grade A for sizes $d \leq M16$ and product grade B for sizes $d > M16$.

If, in special cases, specifications other than those listed in this International Standard are required, they should be selected from existing International Standards, e.g. ISO 261, ISO 898/2, ISO 965, ISO 4759/1.

2 References

ISO 225, *Fasteners — Bolts, screws and nuts — Symbols and designations of dimensions.*

ISO 261, *ISO general purpose metric screw threads — General plan.*

ISO 898/2, *Mechanical properties of fasteners — Part 2: Nuts with specified proof load values.*

ISO 898/5, *Mechanical properties of fasteners — Part 5: Set screws and similar threaded fasteners not under tensile stresses.*

ISO 965, *ISO general purpose metric screw threads — Tolerances.*

ISO 3269, *Fasteners — Acceptance inspection.*

ISO 3506, *Corrosion-resistant stainless steel fasteners — Specifications.*

ISO 4042, *Threaded components — Electroplated coatings.*²⁾

ISO 4759/1, *Tolerances for fasteners — Part 1: Bolts, screws and nuts with thread diameters $\geq 1,6$ and ≤ 150 mm and product grades A, B and C.*

ISO 8839, *Mechanical properties of fasteners — Bolts, screws, studs and nuts made of non-ferrous metals.*

ISO 8992, *Fasteners — General requirements for bolts, screws, studs and nuts.*

1) These will form the subjects of future International Standards.

2) At present at the stage of draft.

3 Dimensions

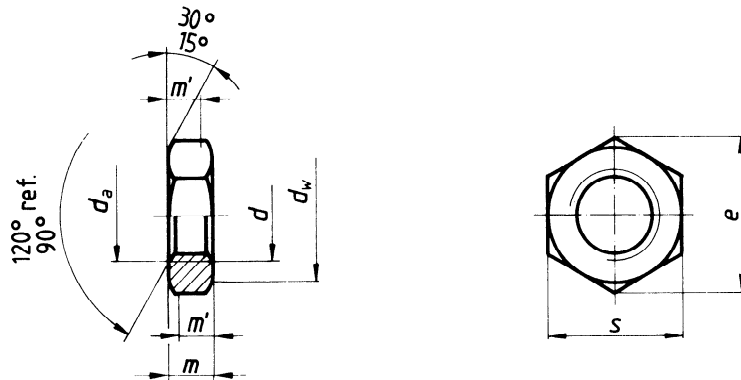

Table 1 – Preferred sizes

Thread size, <i>d</i>		M1,6	M2	M2,5	M3	M4	M5	M6	M8	M10	M12
<i>p</i> ¹⁾		0,35	0,4	0,45	0,5	0,7	0,8	1	1,25	1,5	1,75
<i>d_a</i>	min.	1,6	2	2,5	3	4	5	6	8	10	12
	max.	1,84	2,3	2,9	3,45	4,6	5,75	6,75	8,75	10,8	13
<i>d_w</i>	min.	2,4	3,1	4,1	4,6	5,9	6,9	8,9	11,6	14,6	16,6
<i>e</i>	min.	3,41	4,32	5,45	6,01	7,66	8,79	11,05	14,38	17,77	20,03
<i>m</i>	max.	1	1,2	1,6	1,8	2,2	2,7	3,2	4	5	6
	min.	0,75	0,95	1,35	1,55	1,95	2,45	2,9	3,7	4,7	5,7
<i>m'</i>	min.	0,6	0,8	1,1	1,2	1,6	2,3	2,3	3	3,8	4,6
<i>s</i>	nom. = max.	3,2	4	5	5,5	7	8	10	13	16	18
	min.	3,02	3,82	4,82	5,32	6,78	7,78	9,78	12,73	15,73	17,73

Dimensions in millimetres

Thread size, <i>d</i>		M16	M20	M24	M30	M36	M42	M48	M56	M64
<i>p</i> ¹⁾		2	2,5	3	3,5	4	4,5	5	5,5	6
<i>d_a</i>	min.	16	20	24	30	36	42	48	56	64
	max.	17,3	21,6	25,9	32,4	38,9	45,4	51,8	60,5	69,1
<i>d_w</i>	min.	22,5	27,7	33,2	42,8	51,1	60	69,5	78,7	88,2
<i>e</i>	min.	26,75	32,95	39,55	50,85	60,79	71,3	82,6	93,56	104,86
<i>m</i>	max.	8	10	12	15	18	21	24	28	32
	min.	7,42	9,10	10,9	13,9	16,9	19,7	22,7	26,7	30,4
<i>m'</i>	min.	5,9	7,3	8,7	11,1	13,5	15,8	18,2	21,4	24,3
<i>s</i>	nom. = max.	24	30	36	46	55	65	75	85	95
	min.	23,67	29,16	35	45	53,8	63,1	73,1	82,8	92,8

1) *P* = pitch of the thread.

Table 2 — Non-preferred sizes

Dimensions in millimetres

Thread size, d		M3,5	M14	M18	M22	M27	M33	M39	M45	M52	M60
P ¹⁾		0,6	2	2,5	2,5	3	3,5	4	4,5	5	5,5
d_a	min.	3,5	14	18	22	27	33	39	45	52	60
	max.	4	15,1	19,5	23,7	29,1	35,6	42,1	48,6	56,2	64,8
d_w	min.	5,1	19,6	24,9	31,4	38	46,6	55,9	64,7	74,2	83,4
e	min.	6,58	23,35	29,56	37,29	45,2	55,37	66,44	76,95	88,25	99,21
	max.	2	7	9	11	13,5	16,5	19,5	22,5	26	30
m	min.	1,75	6,42	8,42	9,9	12,4	15,4	18,2	21,2	24,7	28,7
	min.	1,4	5,1	6,7	7,9	9,9	12,3	14,6	17	19,8	23
s	nom. = max.	6	21	27	34	41	50	60	70	80	90
	min.	5,82	20,67	26,16	33	40	49	58,8	68,1	78,1	87,8

1) P = pitch of the thread.

4 Specifications and reference standards

Table 3 — Specifications and reference standards

Material		Steel	Stainless steel	Non-ferrous metal
General requirements	International Standard	ISO 8992		
Thread	Tolerance	6H		
	International Standards	ISO 261, ISO 965		
Mechanical properties	Class	$d < M3$: 14H $M3 < d < M39$: 04-05 $d > M39$: as agreed	$d < M20$: A2-70 $M20 < d < M39$: A2-50 $d > M39$: as agreed
	International Standards	$d < M3$: ISO 898/5 $M3 < d < M39$: 898/2 $d > M39$: as agreed	$d < M39$: ISO 3506 $d > M39$: as agreed	ISO 8839
Tolerances	Product grade	$d < M16$: A $d > M16$: B		
	International Standard	ISO 4759/1		
Finish		as processed	plain	plain
		Requirements for electroplating are covered in ISO 4042. If different electroplating requirements are desired or if requirements are needed for other finishes, they should be negotiated between customer and supplier.		
Acceptability		For acceptance procedure, see ISO 3269.		

5 Designation

Example for the designation of a chamfered hexagon thin nut with thread size $d = M12$ and property class 05:

Hexagon thin nut ISO 4035 - M12 - 05

iTeh STANDARD PREVIEW
(standards.iteh.ai)

This page intentionally left blank

[ISO 4035:1986](#)

<https://standards.iteh.ai/catalog/standards/sist/c7b6b72b-3fd2-4fd5-8556-3f3ca4404ccd/iso-4035-1986>

iTeh STANDARD PREVIEW
(standards.iteh.ai)

This page intentionally left blank

[ISO 4035:1986](#)

<https://standards.iteh.ai/catalog/standards/sist/c7b6b72b-3fd2-4fd5-8556-3f3ca4404ccd/iso-4035-1986>

iTeh STANDARD PREVIEW
(standards.iteh.ai)

This page intentionally left blank

[ISO 4035:1986](#)

<https://standards.iteh.ai/catalog/standards/sist/c7b6b72b-3fd2-4fd5-8556-3f3ca4404ccd/iso-4035-1986>