**Trajnost lesa in lesnih proizvodov – Ugotavljanje možnosti za impregnacijo
vzorcev lesa z zaščitnimi sredstvi za les - Laboratorijska metoda**

Durability of wood and wood-based products - Determination of treatability of timber
species to be impregnated with wood preservatives - Laboratory method

iTeh STANDARD PREVIEW
(standards.iteh.ai)

[SIST-TP CEN/TR 14734:2005](https://standards.iteh.ai/catalog/standards/sist/0ef9073d-f8a8-4491-a1dd-6a740d39305e/sist-tp-cen-tr-14734-2005)
[https://standards.iteh.ai/catalog/standards/sist/0ef9073d-f8a8-4491-a1dd-
6a740d39305e/sist-tp-cen-tr-14734-2005](https://standards.iteh.ai/catalog/standards/sist/0ef9073d-f8a8-4491-a1dd-6a740d39305e/sist-tp-cen-tr-14734-2005)

iTeh STANDARD PREVIEW
(standards.iteh.ai)

SIST-TP CEN/TR 14734:2005

<https://standards.iteh.ai/catalog/standards/sist/0ef9073d-ffa8-4491-a1dd-6a740d39305e/sist-tp-cen-tr-14734-2005>

ICS 79.040

English version

Durability of wood and wood-based products - Determination of
treatability of timber species to be impregnated with wood
preservatives - Laboratory method

Durabilité du bois et des matériaux dérivés du bois -
Détermination de l'imprégnabilité d'essences de bois par
des produits de préservation - Méthode de laboratoire

Dauerhaftigkeit von Holz und Holzwerkstoffen -
Laboratoriumsverfahren zur Bestimmung der Tränkbarkeit
von Holzarten, die mit Holzschutzmitteln imprägniert
werden sollen

This Technical Report was approved by CEN on 3 November 2003. It has been drawn up by the Technical Committee CEN/TC 38.

CEN members are the national standards bodies of Austria, Belgium, Cyprus, Czech Republic, Denmark, Estonia, Finland, France, Germany, Greece, Hungary, Iceland, Ireland, Italy, Latvia, Lithuania, Luxembourg, Malta, Netherlands, Norway, Poland, Portugal, Slovakia, Slovenia, Spain, Sweden, Switzerland and United Kingdom.

iTeh STANDARD PREVIEW
(standards.iteh.ai)

[SIST-TP CEN/TR 14734:2005](https://standards.iteh.ai/catalog/standards/sist/0ef9073d-f8a8-4491-a1dd-6a740d39305e/sist-tp-cen-tr-14734-2005)

<https://standards.iteh.ai/catalog/standards/sist/0ef9073d-f8a8-4491-a1dd-6a740d39305e/sist-tp-cen-tr-14734-2005>



EUROPEAN COMMITTEE FOR STANDARDIZATION
COMITÉ EUROPÉEN DE NORMALISATION
EUROPÄISCHES KOMITEE FÜR NORMUNG

Management Centre: rue de Stassart, 36 B-1050 Brussels

Contents		Page
1	Scope	5
2	Principle	5
3	Reagents	5
4	Apparatus	5
5	Test specimens	6
6	Procedure	7
7	Data handling	9
8	Test report	11
	Annex A Guidance on sampling	12
	Annex B Example of a test report	14
	Bibliography	16

iTeh STANDARD PREVIEW
(standards.iteh.ai)

[SIST-TP CEN/TR 14734:2005](https://standards.iteh.ai/catalog/standards/sist/0ef9073d-f8a8-4491-a1dd-6a740d39305e/sist-tp-cen-tr-14734-2005)
<https://standards.iteh.ai/catalog/standards/sist/0ef9073d-f8a8-4491-a1dd-6a740d39305e/sist-tp-cen-tr-14734-2005>

Foreword

This document (CEN/TR 14734:2004) has been prepared by Technical Committee CEN/TC 98 "Durability of wood and wood-based products", the secretariat of which is held by AFNOR.

The status of this document as a Technical Report has been chosen because the method is useful but should be confirmed by experimentation.

This document includes a Bibliography.

iTeh STANDARD PREVIEW **(standards.iteh.ai)**

SIST-TP CEN/TR 14734:2005

<https://standards.iteh.ai/catalog/standards/sist/0ef9073d-ffa8-4491-a1dd-6a740d39305e/sist-tp-cen-tr-14734-2005>

Introduction

The basis for this document was prepared as being part of the work for SMT project MAT-CT 94061 project number 3307: Improvement of CEN standards by short term methods for testing the natural durability and treatability of solid wood and wood based panel products.

It provides the means whereby the treatability of sapwood or heartwood of different wood species can be determined in order to determine likely reaction to impregnation with wood preservatives. Such an assessment provides data for use in EN 351-1 which establishes a system for specifying the treatment of wood with wood preservatives based upon the penetration and retention of preservatives achieved by the treatment process. EN 351-1 recognises that different wood species respond to treatment differently depending on their ability to absorb preservative, and requires a different level of compliance depending on the treatability of the wood concerned. While EN 350-2 includes a subjective classification of the treatability of different wood species using a four class system, the method described in this document provides the means to determine the treatability objectively.

Although the method described uses an aqueous solution as the impregnating liquid, the results can be used to give guidance on the treatability of the samples under test. Alternatively, the method can be modified using other preservative types, e.g. organic solvent or emulsion preparations, if the response of the wood to a specific preservative is required. However, it should be noted that the method does not take account of preservative formulations where the active ingredients are selectively adsorbed on to the wood substrate resulting in the solvent penetrating more deeply than the biocides.

STANDARD PREVIEW
(standards.iteh.ai)

[SIST-TP CEN/TR 14734:2005](https://standards.iteh.ai/catalog/standards/sist/0ef9073d-fa8-4491-a1dd-6a740d39305e/sist-tp-cen-tr-14734-2005)

<https://standards.iteh.ai/catalog/standards/sist/0ef9073d-fa8-4491-a1dd-6a740d39305e/sist-tp-cen-tr-14734-2005>

1 Scope

This Technical Report describes a laboratory method for the determination of the treatability of wood in order to determine the likely reaction of different wood species to impregnation with wood preservatives. It can also be used to investigate variation between samples of the same species but of different origin.

2 Principle

After moisture and density determination of each of test specimens, a set of test specimens is impregnated with copper sulfate solution in accordance with a standard test procedure. After application of an indicator solution to the exposed cross-section and to one of the exposed longitudinal surfaces of each of test specimens, the lateral and axial penetration is measured and the treatability class is evaluated.

3 Reagents

3.1 Copper sulfate pentahydrate, solution, mass fraction of 5 %.

Dissolve 50 g of copper sulfate pentahydrate ($\text{CuSO}_4 \cdot 5\text{H}_2\text{O}$) in 950 g water.

NOTE The volume of copper sulfate solution required will depend on the capacity of the impregnation apparatus.

3.2 Indicator solution iTeh STANDARD PREVIEW

For the indication of the penetration an indicator solution, e.g. chrome azurol S, can be used. Dissolve 0,5 g chrome azurol S and 5 g sodium acetate in 100 ml water.

NOTE Other indicators can be used. [SIST-TP CEN/TR 14734:2005
https://standards.iteh.ai/catalog/standards/sist/0ef9073d-f8a8-4491-a1dd-6a740d39305e/sist-tp-cen-tr-14734-2005](https://standards.iteh.ai/catalog/standards/sist/0ef9073d-f8a8-4491-a1dd-6a740d39305e/sist-tp-cen-tr-14734-2005)

3.3 Sealing compound

A sealing compound which is inert to the copper sulfate solution (3.1) and unaffected by the test conditions.

4 Apparatus

Ordinary laboratory apparatus and:

4.1 **Balance**, capable of weighing to an accuracy of 0,01 g.

4.2 **Conditioning chamber**, well ventilated and controlled at $(20 \pm 2)^\circ\text{C}$ and $(65 \pm 5)\%$ relative humidity.

4.3 **Measuring device**, capable of measuring the dimensions of test samples of up to 40 mm in size and to an accuracy of 0,1 mm.

4.4 **Drying oven**, capable of being controlled at $(103 \pm 2)^\circ\text{C}$.

4.5 **Desiccator**, with efficient desiccant (silica gel for example).

4.6 Impregnation apparatus, consisting of a chamber and header tank with ancillary vacuum and pressure pumps capable of exerting a vacuum of $(1 \pm 0,5) \text{ kPa}^1$ and a pressure of $9,0 \times 10^2 \text{ kPa}$. The pipe work between the chamber and the pumps shall be designed so that adding or draining treatment solutions can be achieved while maintaining the existing pressure in the vessel. A typical apparatus is shown in Figure 1.

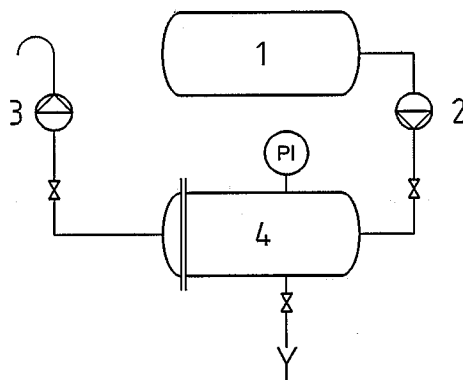

Key

- 1 Header tank
- 2 Pump
- 3 Vacuum pump
- 4 Chamber

iTeh STANDARD PREVIEW
 Figure 1 — Typical impregnation apparatus
 (standards.iteh.ai)

5 Test specimens

[SIST-TP CEN/TR 14734:2005](https://standards.iteh.ai/catalog/standards/sist/0ef9073d-f8a8-4491-a1dd-6a740d39305e/sist-tp-cen-tr-14734-2005)

<https://standards.iteh.ai/catalog/standards/sist/0ef9073d-f8a8-4491-a1dd-6a740d39305e/sist-tp-cen-tr-14734-2005>

5.1 Preparation

Prepare a minimum of ten test specimens, each from a different plank of the wood species under test (see also 6.2). The test specimens of heartwood and sapwood shall be identified and marked appropriately. The wood shall be sound, straight-grained and without knots and the visible features of the wood shall be given for example: resin pockets, cross-grain, widths of annual rings and proportion of latewood. At the time of test, the moisture content of the test specimens shall be between 13 % and 18 %.

NOTE 1 Guidance on sampling of wood is given in annex A.

NOTE 2 Wood conditioned to constant mass in a chamber (4.2) at 65 % relative humidity and 20 °C will attain a moisture content of 10 % (*m/m*) to 14 % (*m/m*).

From each plank, prepare a strip having a length of at least 800 mm and a cross-section of $(40 \pm 0,3) \times (40 \pm 0,3) \text{ mm}$. The lateral surfaces shall be planed and shall be true radial and tangential surfaces. Cross cut 15 mm to 20 mm from one end and discard. Cross cut a $(10 \pm 0,1) \text{ mm}$ long sample from the same end, for moisture content and density determination (see 6.1). Trim the other end of the remaining length to give a test specimen $(750 \pm 1) \text{ mm}$ long for impregnation. Number both test specimens so as to retain the identity of the plank.

Apply the sealing compound (3.3) to one cross-section end of each test specimen for impregnation and allow to set.

1) 1 kPa = 10 mbar.

6 Procedure

6.1 Moisture content and density determination

Weigh each test specimen for moisture content determination to the nearest 0,01 g using the balance (4.1), to determine the initial mass (m_0). Transfer the test specimens to the drying oven (4.4). Dry the test specimens for 18 h to 24 h, cool to room temperature in a desiccator (4.5), weigh each test specimen to the nearest 0,01 g and record the final mass (m_1). Calculate the moisture content of each test specimen by expressing the water content ($m_0 - m_1$) as a percentage of the dry mass (m_1). Calculate the density of each test specimen, expressed as kilograms per cubic metre, using the oven dry mass (m_1) and the nominal volume of 16 cm³.

6.2 Impregnation of test specimens (standard procedure)

Place the test specimens in the impregnation chamber (4.6) in such a way that they do not touch each other and that they do not float when the chamber is filled with the copper sulfate solution (3.1).

NOTE 1 A suitable arrangement can be achieved by separating the stacked test specimens with small sticks and either tying down the test specimens or placing weights on the top of the stack.

Seal the chamber and by means of the vacuum pump, reduce the pressure to $(1,0 \pm 0,5)$ kPa. Maintain this vacuum for 45 min. Then, with the vacuum pump running, introduce the copper sulfate solution (3.1) so that the impregnation chamber and the header tank are completely filled. Release the vacuum so that the pressure in the apparatus returns to atmospheric pressure. Apply a pressure of $(9,0 \pm 0,5) \times 10^2$ kPa and maintain for 120 min. Release the pressure so that the apparatus returns to atmospheric pressure. Drain the copper sulfate solution from the chamber.

Remove the test specimens from the chamber and stack in a well-ventilated area to allow drying to take place. Allow to dry until the moisture content of the test specimens is below the fibre saturation point.

NOTE 2 A moisture meter of the two-pronged electrical conductivity type is suitable for this purpose.

6.3 Measurement of penetration

Cut each test specimen according to the pattern given in Figure 2, using equipment which provides a fine-sawn finish.

NOTE The cutting should be in the radial plan and should be from the end that was nearest the end seal.