



Designation: ~~C1725~~—~~10~~ **C1725 – 17**

Standard Guide for Hot Cell Specialized Support Equipment and Tools¹

This standard is issued under the fixed designation C1725; the number immediately following the designation indicates the year of original adoption or, in the case of revision, the year of last revision. A number in parentheses indicates the year of last reappraisal. A superscript epsilon (ϵ) indicates an editorial change since the last revision or reappraisal.

1. Scope

1.1 Intent:

1.1.1 This guide presents practices and guidelines for the design and implementation of equipment and tools to assist assembly, disassembly, alignment, fastening, maintenance, or general handling of equipment in a hot cell. Operating in a remote hot cell environment significantly increases the difficulty and time required to perform a task compared to completing a similar task directly by hand. Successful specialized support equipment and tools minimize the required effort, reduce risks, and increase operating efficiencies.

1.2 Applicability:

1.2.1 This guide may apply to the design of specialized support equipment and tools anywhere it is remotely operated, maintained, and viewed through shielding windows or by other remote viewing systems.

1.2.2 Consideration should be given to the need for specialized support equipment and tools early in the design process.

1.2.3 The values stated in inch-pound units are to be regarded as standard. The values given in parentheses are mathematical conversions to SI units that are provided for information only and are not considered standard.

1.3 Caveats:

1.3.1 This guide is generic in nature and addresses a wide range of remote working configurations. Other acceptable and proven international configurations exist and provide options for engineer and designer consideration. Specific designs are not a substitute for applied engineering skills, proven practices, or experience gained in any specific situation.

1.3.2 This guide does not supersede federal or state regulations, or both, or codes applicable to equipment under any conditions.

1.3.3 *This guide does not purport to address all of the safety concerns, if any, associated with its use. It is the responsibility of the user of this standard to establish appropriate safety and health practices and determine the applicability of regulatory limitations prior to use.*

1.4 This international standard was developed in accordance with internationally recognized principles on standardization established in the Decision on Principles for the Development of International Standards, Guides and Recommendations issued by the World Trade Organization Technical Barriers to Trade (TBT) Committee.

2. Referenced Documents

2.1 ASTM Standards:²

[A193/A193M Specification for Alloy-Steel and Stainless Steel Bolting for High Temperature or High Pressure Service and Other Special Purpose Applications](#)

[A354 Specification for Quenched and Tempered Alloy Steel Bolts, Studs, and Other Externally Threaded Fasteners](#)

[A453/A453M Specification for High-Temperature Bolting, with Expansion Coefficients Comparable to Austenitic Stainless Steels](#)

[A962/A962M Specification for Common Requirements for Bolting Intended for Use at Any Temperature from Cryogenic to the Creep Range](#)

[C859 Terminology Relating to Nuclear Materials](#)

[C1217 Guide for Design of Equipment for Processing Nuclear and Radioactive Materials](#)

[C1533 Guide for General Design Considerations for Hot Cell Equipment](#)

[C1554 Guide for Materials Handling Equipment for Hot Cells](#)

¹ This guide is under the jurisdiction of ASTM Committee C26 on Nuclear Fuel Cycle and is the direct responsibility of Subcommittee C26.14 on Remote Systems. Current edition approved June 15, 2010; June 1, 2017. Published August 2010; June 2017. Originally approved in 2010. Last previous edition approved in 2010 as C1725 – 10. DOI: 10.1520/C1725-10; 10.1520/C1725-17.

² For referenced ASTM standards, visit the ASTM website, www.astm.org, or contact ASTM Customer Service at service@astm.org. For Annual Book of ASTM Standards volume information, refer to the standard's Document Summary page on the ASTM website.

C1615 Guide for Mechanical Drive Systems for Remote Operation in Hot Cell Facilities

C1661 Guide for Viewing Systems for Remotely Operated Facilities

SI10-02 IEEE/ASTM SI 10 American National Standard for Use of the International System of Units (SI): The Modern Metric System

2.2 *Federal Regulations:*³

10 CFR 830.120 Subpart A, Nuclear Safety Management, Quality Assurance Requirements

2.3 *Other Standards:*⁴

ANSI/ASME NQA-1 Quality Assurance Requirements for Nuclear Facility Applications

ANSI/ISO/ASQ 9001 Quality Management Standard Requirements

3. Terminology

3.1 The terminology employed in this guide conforms to industry practice insofar as practicable.

3.2 For definitions of general terms used to describe nuclear materials, hot cells, and hot cell equipment, refer to Terminology C859.

3.3 *Definitions of Terms Specific to This Standard:*

3.3.1 *acorn-head (cone-head) fastener*—a bolt or screw with a rounded spherical head tapering into a standard hex head resembling the shape of the bottom portion of an acorn (or cone), the purpose of which is used to guide and align a tool onto the bolt head.

3.3.2 *alignment (guide) pin*—a pin used to align two mating components by mating a pin mounted in one component with a precisely sized and positioned hole in the mating part. Multiple pins are typically required for proper alignment depending on the configuration and orientation of the mating surfaces.

3.3.3 *captive fastener*—a bolt or screw physically retained on a component that remains attached when mating parts are separated. Using captive fasteners eliminates the risk of dropping the fastener and helps to maintain the fastener in a ready to use position. It can also apply to nuts when mating components are too thin for threading.

3.3.4 *hot cell—grapple*—an isolated shielded room that provides a controlled environment for containing highly radioactive and typically contaminated material and equipment. The radiation levels within a hot cell are typically 100 rad/h (1 Gy/h) or higher. a removable tool that attached by means of a non-threaded connection to equipment and interfaces with an overhead crane or electro-mechanical manipulator to lift and move the equipment.

3.3.5 *lifting bail*—lifting handle, hook, or cable generally attached over the center of gravity of the equipment to aid remote handling.

3.2.6 *mockup*—a facility used to represent the physical environment of a radiological facility in a non-radiological setting. Mockups are full scale facilities used to assure proper clearances, accessibility, maintainability, visibility, or operability of items to be subsequently installed in a radiological environment. 29273-8b37-4c9e-b1af-435a5e4eb9a1/astm-c1725-17

3.2.7 *master-slave manipulator (MSM)*—a device to remotely handle items, tools, or radioactive material in a hot cell. The in-cell or slave portion of the manipulator replicates the actions of an operator outside the cell by means of a mechanical connection between the two, usually with metal tapes or cables. Typically, MSMs have lifting capacities of 20 to 50 lbs (9 to 23 kg).

3.3.6 *power manipulator*—manipulator controlled by an operator outside of the hot cell with the in-cell slave-arm powered by electric, pneumatic, or hydraulic actuators.

4. Significance and Use

4.1 This guide is relevant to the design of specialized support equipment and tools that are remotely operated, maintained, or viewed through shielding windows, or combinations thereof, or by other remote viewing systems.

4.2 Hot cells contain substances and processes that may be extremely hazardous to personnel or the external environment, or both. Process safety and reliability are improved with successful design, installation, and operation of specialized mechanical and support equipment.

4.3 Use of this guide in the design of specialized mechanical and support equipment can reduce costs, improve productivity, reduce failed hardware replacement time, and provide a standardized design approach.

³ Available from U.S. Government Printing Office Superintendent of Documents, 732 N. Capitol St., NW, Mail Stop: SDE, Washington, DC 20401, <http://www.access.gpo.gov>.

⁴ Available from American National Standards Institute (ANSI), 25 W. 43rd St., 4th Floor, New York, NY 10036, <http://www.ansi.org>.

5. Design Requirements

5.1 The complexity, performance, reliability, and life expectancy of support equipment will be determined by the facility purpose, configuration, and radiation levels. A production facility may require robust designs intended to be extensively used for the life of the facility. In contrast, equipment for a research or analytical facility may be intended only for limited short-term experiments.

5.2 Present and future radiation levels, chemical exposures, and other severe environmental conditions should be well understood for their impact on material performance, life expectancy, and disposal.

5.3 Limitations of the facility handling equipment should be identified and possible constraints imposed on support equipment and tools understood. Applicable inputs include lift capacities, range of motion, force limits, and areas of coverage. A specific example is to use the repeatable minimum incremental movement of the handling equipment to size features for easy alignment with appropriate tool.

5.4 Operator interfaces with handling equipment should also be identified to understand how the operator verifies successful task completion or recognizes when a problem occurs. Refer to Guides [C1217](#), [C1533](#), [C1554](#), [C1615](#), and [C1661](#) for additional descriptions of hot cell equipment design requirements.

6. Quality Assurance, Qualification and Acceptance

6.1 Facility owners and program managers should establish a quality assurance program to assure proper equipment operation and reliability consistent with that required for facility operations as outlined by law or the agency of jurisdiction. Quality assurance programs may be required to comply with 10 CFR830.120, ANSI/ASME NQA-1, or ANSI/ISO/ASQ 9001.

6.2 Quality assurance specifications should be established to ensure all procurement and fabrication meets the design specifications. The level of complexity and risk consequences should be used to determine the level of required certification documentation and the degree of inspection.

6.3 Components should be tested in a simulated operating environment (mockup) before in-cell installation or use to verify remote operability, maintainability, and to reduce the risk of unexpected problems. The level of complexity and risk consequences should be used to determine the degree of simulation required to test designs before remote implementation.

6.4 Equipment to be used in nuclear or other regulatory controlled facilities may be required to meet specific qualification requirements and documentation by the regulatory agency prior to installation or use.

7. Remote Handling Features

7.1 *Manipulator Finger Guides*—Guides for the fingers on the in-cell portion of the manipulators provide positive grips when handling items and prevent unnecessary damage and delays resulting from dropped items. [Fig. 1](#) is an example of finger grips fabricated from sheet metal and attached to a tool. [Fig. 2](#) shows an example of flats machined into a round shaft to match the manipulator fingers.

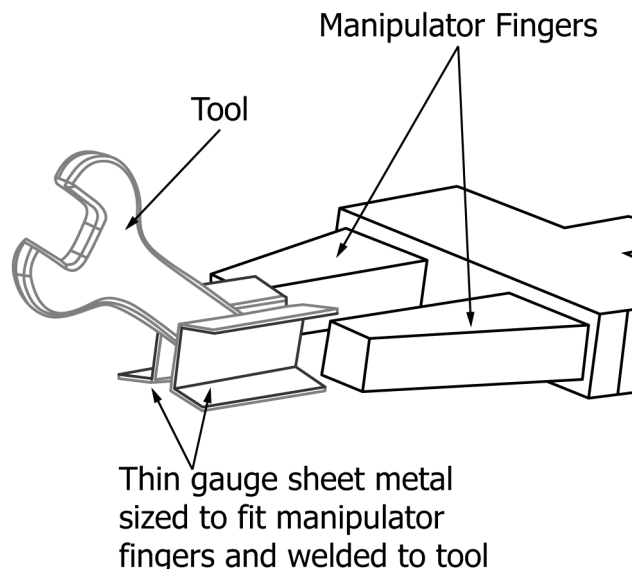

FIG. 1 Sheet Metal Grips

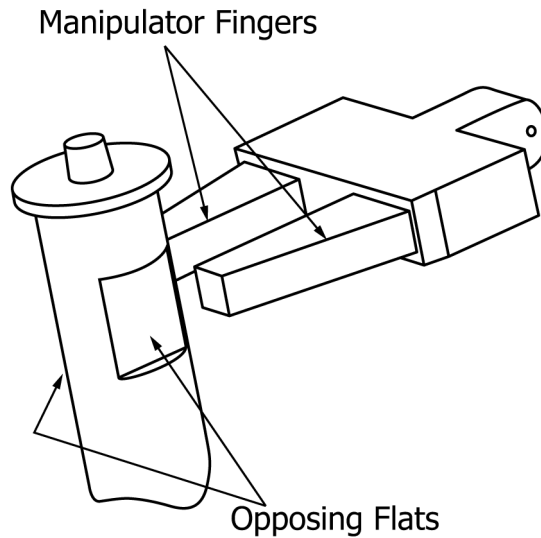

FIG. 2 Machined Flats

7.2 *Positive Latch Indicators*—Latch indicators identify when a component is properly positioned or when a grapple is properly engaged. Fig. 3 is an example of a positive latch indicator for a threaded grapple that must engage mating threads in a non-visible location. As the grapple is threaded into position, the push rod contacts the bottom surface of the mating hole and slides a sleeve over a color-coded band. Full engagement is indicated when the color band is no longer visible.

7.3 *Lanyards*—A lanyard may be used to secure loose parts at risk of being dropped. Lanyards may also be attached to connectors or pins to aid in releasing latching mechanisms that are difficult to operate when using manipulators. Lanyards are typically thin wire ropes that are attached to the part and to a more rigid or fixed equipment item. Fig. 4 shows an example of a removable pin being secured using a lanyard.

7.4 *Lifting Features:*

7.4.1 *Hooks*—Crane hooks used in hot cells typically have no motorized rotational capability. To compensate for this limitation, hooks can be modified or an additional special purpose hook can be used below the regular hook. Fig. 5 is an example of a modified hook with an extended nose that guides the hook onto lifting features. Fig. 6 is an example of a detachable treble hook requiring minimal rotation for alignment. The treble hook is also inherently self-standing when removed from the regular crane hook and stored. The crane hooks illustrated do not have load locking mechanisms. Locking mechanisms that lock the load into the hook require special consideration. As a result, hooks without locks are common and often designed with deeper throats to help secure loads during handling. When used, locks should be designed so actuator failures leave the lock in the open position. A lock in the

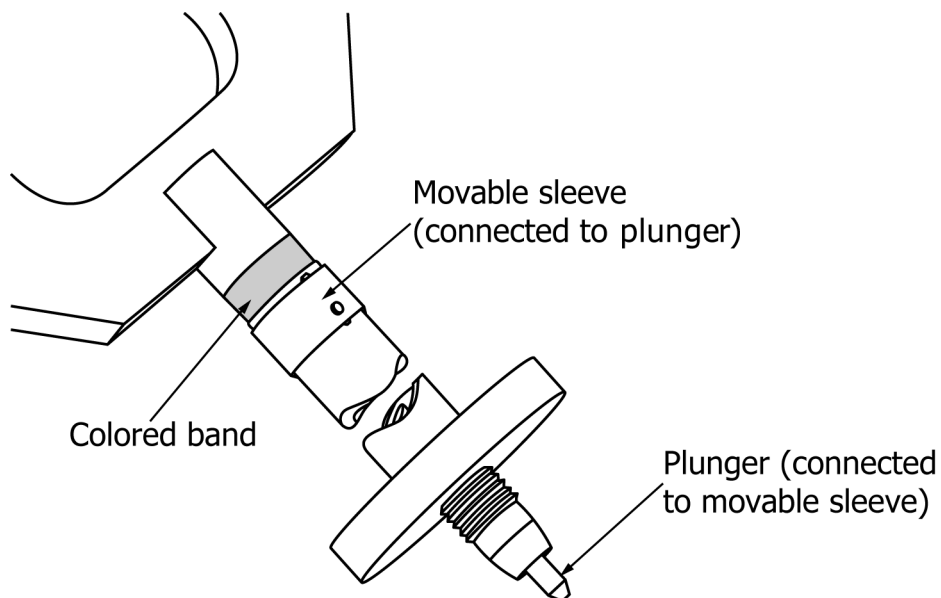

FIG. 3 Positive Latch Indicator

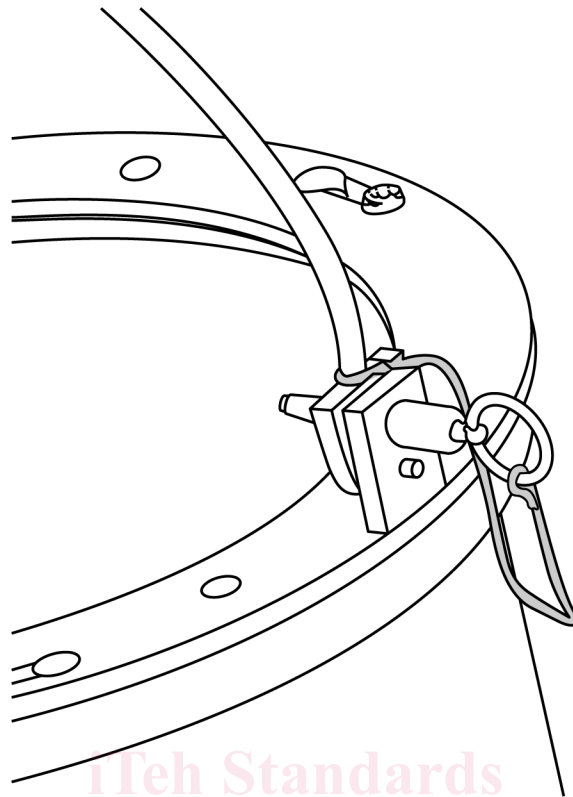

FIG. 4 Lanyard Securing Removable Pin

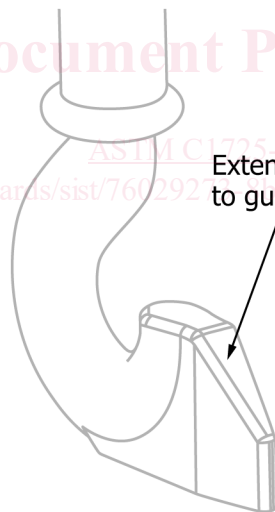

FIG. 5 Extended Nose

open position should not hinder normal crane hook operation. Manual actuation of a lock limits its use to locations where the locking mechanisms can be reached with a manipulator.

7.4.2 *Swivel Hoist Rings*—Swivel hoist rings have been used extensively in hot cells for lifting equipment because of their multidirectional loading capability. They swivel 360° to compensate for pitch, roll and sway when lifting unbalanced loads. Fig. 7 is an illustration of a typical swivel hoist ring using a convenient deep-socket head screw for ease of installation.

7.4.3 *Lifting Bails*—Lifting bails on equipment should be self-standing or have locking positions maintaining clearances for easy engagement of hooks as shown in Fig. 8. Cable bails should be constructed from self-supporting stiff material and attached using a shoulder bolt with large diameter washer to secure the loop at each end. Fig. 9 shows details for typical cable bail attachment. Bails should be located over the center of gravity to avoid uncontrollable motions when the lifted component becomes unrestrained. Potential shifting of the center of gravity needs to be considered when multiple handling configurations exist, such as handling a container either empty or loaded.

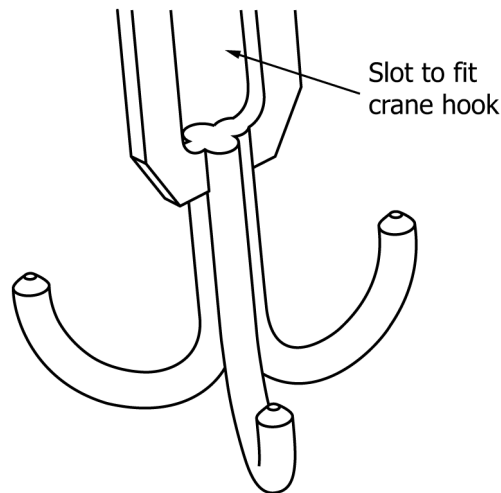

FIG. 6 Detachable Treble Hook

7.4.4 *Grapples*—A grapple is a lifting device that is typically separate from the equipment to be lifted, and may be designed to lift several different equipment items. Using grapples is a way to standardize lifting schemes for multiple pieces of equipment and it may simplify lifting designs and improve ease of handling. Grapples generally have positive locking mechanisms. The locking mechanisms should be operable by manipulators and include latched and unlatched indication. Fig. 10 is an example of a ball-detent quick-lifting grapple designed to handle flat cover plates and container lids. To use, the grapple is inserted a mating hole and locked by rotating a handle pushing locking balls outward into a larger diameter recess. The mating hole in the load must be precisely machined with proper clearance for expansion of the locking balls and also provide a shoulder to restrain the balls when the grapple lifts the load. The lifting capacity is limited by the material characteristics of the locking balls and hole shoulder. As shown, the hole in the load may be a single diameter when the mating plate is thin or a stepped hole when thicker. Fig. 11 illustrates a grapple designed to handle round bails and is equipped with a sliding sleeve to lock the bail in the grip.

7.5 *Positioning and Clamping Features:*

7.5.1 *Toggle Clamps*—Toggle clamps come in a variety of sizes and configurations and function as a quick action clamping device. Toggle clamps are typically used in light-duty clamping applications for parts that are frequently installed and removed. They are useful in hot cell environments because they are easily actuated using master-slave manipulators. An advantage of most toggle clamp designs are that when the handle is opened, the clamping arm completely clears the work area, providing clearance for loading and unloading parts. Most toggle clamps feature locking handles to provide a continuous holding force using an over-center cam action that also provides protection against unintentional release. See Fig. 12.

7.5.2 *Double-acting Ball Lock (Quick Release) Pins*—Single-acting ball lock pins require two manipulators to operate and are not suitable for remote operations. Double-acting pins provide positive locking for many types of remote applications. An internal spring holds the spindle in a center position locking the balls. Pushing the spindle retracts the balls allowing insertion of the pin and pulling the spindle also retracts the balls allowing removal of the pin. This motion can be accomplished with a single manipulator for both insertion and removal of the pin. These pins are typically available in heat treated steel to withstand high shear loads or stainless steel to resist corrosion. The mating-hole clearance for the pin must be precisely machined per manufacturer's instructions for reliable operation. Different handle styles are available. The ring handle style shown in Fig. 13 allows insertion of a slave finger into the ring for a positive grip and is recommended for most applications. The ring is often brazed to the spindle to fix it in the most accessible position. A captive configuration is shown in Fig. 13. For non-captive designs, a lanyard is recommended for securing the pin to equipment as shown in Fig. 4. Lanyard use eliminates the potential for dropping loose pins while handling.

7.5.3 *Spring Plungers*—Retractable spring plungers are useful as positioners, locating pins, and indexing devices in remote equipment applications. The locking T- and L- handle plungers have a rest position where the plunger can stay in the retracted position as shown in Fig. 14. The T- and L- handles are easily withdrawn and re-engaged using master-slave manipulators.

7.6 *Alignment Features*—Mating components often need guides to assure successful remote assembly and to prevent damage or incorrect assembly orientation.

7.6.1 *Guide Pins*—Guide pins provide precise alignments for applications such as when mating electrical connectors. Dual diameter (two stage) or long taper pins provide initial gross alignment followed by fine alignment and are recommended when multiple pins are used with a single connection. The small pin diameter provides an initial gross alignment to the mating hole that transitions to the final precise alignment as the large pin diameter engages. Multiple pins of unequal length allow for an easier one-hole-at-a-time engagement. The use of a single pin controls positional alignment with rotation remaining free. Engaging a second pin controls angular orientation and may be a pin mating to a slot with relaxed tolerances in the slotted direction as shown