



Designation: D968 – 17

Standard Test Methods for Abrasion Resistance of Organic Coatings by Falling Abrasive¹

This standard is issued under the fixed designation D968; the number immediately following the designation indicates the year of original adoption or, in the case of revision, the year of last revision. A number in parentheses indicates the year of last reapproval. A superscript epsilon (ϵ) indicates an editorial change since the last revision or reapproval.

This standard has been approved for use by agencies of the U.S. Department of Defense.

1. Scope*

1.1 These test methods cover the determination of the resistance of organic coatings to abrasion produced by abrasive falling onto coatings applied to a plane rigid surface, such as a metal or glass panel.

1.2 Two test methods based on different abrasives are covered as follows:

	Sections
Method A—Falling Sand Abrasion Test	6 – 13
Method B—Falling Silicon Carbide Abrasion Test	14 – 21

1.3 These methods should be restricted to testing in only one laboratory when numerical values are used because of the poor reproducibility of the methods (see 13.1.2 and 21.1.2). Interlaboratory agreement is improved significantly when ranking is used in place of numerical values.

1.4 The values stated in SI units are to be regarded as the standard with the exception of mils when determining coating thickness. The values given in parentheses are for information only.

1.5 *This standard does not purport to address the safety concerns, if any, associated with its use. It is the responsibility of the user of this standard to establish appropriate safety and health practices and determine the applicability of regulatory limitations prior to use.*

1.6 *This international standard was developed in accordance with internationally recognized principles on standardization established in the Decision on Principles for the Development of International Standards, Guides and Recommendations issued by the World Trade Organization Technical Barriers to Trade (TBT) Committee.*

¹ These test methods are under the jurisdiction of ASTM Committee D01 on Paint and Related Coatings, Materials, and Applications and are the direct responsibility of Subcommittee D01.23 on Physical Properties of Applied Paint Films.

Current edition approved June 1, 2017. Published June 2017. Originally approved in 1948. Last previous edition approved in 2015 as D968 – 15. DOI: 10.1520/D0968-17.

2. Referenced Documents

2.1 ASTM Standards:²

D823 Practices for Producing Films of Uniform Thickness of Paint, Varnish, and Related Products on Test Panels

D1005 Test Method for Measurement of Dry-Film Thickness of Organic Coatings Using Micrometers

D7091 Practice for Nondestructive Measurement of Dry Film Thickness of Nonmagnetic Coatings Applied to Ferrous Metals and Nonmagnetic, Nonconductive Coatings Applied to Non-Ferrous Metals

E11 Specification for Woven Wire Test Sieve Cloth and Test Sieves

2.2 Other Standards:

ANSI B74.12 Specifications for the Size of Abrasive Grain — Grinding Wheels, Polishing and General Industrial Uses³

FEPA Standard 42-2:2006 Grains of Fused Aluminum Oxide, Silicon Carbide and other Abrasive Materials for Bonded Abrasives and for General Applications — Micrometers F230 to F2000⁴

3. Terminology

3.1 Definitions of Terms Specific to This Standard:

3.1.1 *abrasion resistance, n*—the amount of abrasive required to wear through a unit film thickness of the coating.

4. Summary of Test Method

4.1 Abrasive is allowed to fall from a specified height through a guide tube onto a coated panel until the substrate becomes visible. The amount of abrasive per unit film thickness is reported as the abrasion resistance of the coating on the panel. Silica sand or silicon carbide may be used, as specified.

² For referenced ASTM standards, visit the ASTM website, www.astm.org, or contact ASTM Customer Service at service@astm.org. For *Annual Book of ASTM Standards* volume information, refer to the standard's Document Summary page on the ASTM website.

³ Available from American National Standards Institute (ANSI), 25 W. 43rd St., 4th Floor, New York, NY 10036, <http://www.ansi.org>.

⁴ Available from Federation of European Producers of Abrasives (FEPA), 20 av., Reille, Paris, F-75014, www.fepa-abrasives.com.

*A Summary of Changes section appears at the end of this standard



FIG. 1 Apparatus for Falling Sand Abrasion Test

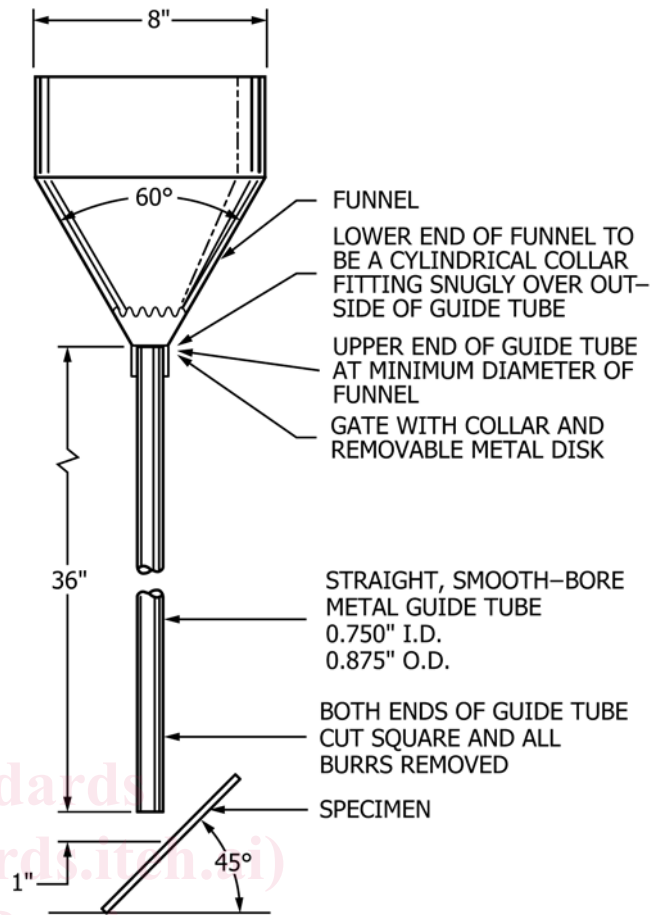

NOTE 1—All dimensions are given in inches. 1 in. = 25.4 mm.

FIG. 2 Design Details of Abrasion Test Apparatus

5. Significance and Use

5.1 Silica sand produces a slower rate of abrasion for organic coatings than that provided by silicon carbide. For some types of coatings, it may also provide greater differentiation.

5.2 The abrasion resistance scales produced by the two methods differ, but the methods provide approximately the same rankings of coatings for abrasion resistance.

5.3 Each of the methods has been found useful for rating the abrasion resistance of specific types of coatings. For example Method A (falling sand) has been used for rating floor coatings while Method B (falling silicon carbide) has been used for rating coatings for ship decks.

METHOD A—FALLING SAND ABRASION TEST⁵

6. Apparatus and Materials

6.1 *Abrasion Tester*, as illustrated in Fig. 1 and Fig. 2. A gate for starting the flow of abrasive is located near the top of the guide tube. It consists of a metal disk inserted into a slit in the side of the guide tube with a collar covering the slit. The guide tube shall be firmly supported in a vertical position over a suitable receptacle, which shall contain a support for holding the coated panel at an angle of 45° to the vertical. The opening of the tube is directly above the area to be abraded and the

distance from the tube to the coated surface face at the nearest point is 25 mm (1 in.) when measured in the vertical direction. The base of the apparatus shall be fitted with adjusting screws for properly aligning the equipment.

6.2 *Standard Abrasive*—Natural silica sand from the St. Peters or Jordan sandstone deposits (located in the central United States) shall be considered standard when graded as follows after 5 min of continuous sieving. Use the sieves described in Specification E11.

- 0 % retained on a No. 16 (1.18 mm) sieve
- Maximum 15 % retained on a No. 20 (850 μm) sieve
- Minimum 80 % retained on a No. 30 (600 μm) sieve
- Maximum 5 % passing a No. 30 (600 μm) sieve

The sand is characterized by its grain shape and has a silicon dioxide content greater than 99 %.

NOTE 1—The abrading qualities of sand obtained from different sources may differ slightly even though the sand meets the sieve requirements. Therefore, for maximum precision of test results, purchaser and seller should use sand from the same source.

7. Test Specimens

7.1 Apply uniform coatings of the material to be tested to a plane, rigid surface such as a metal or glass panel. Prepare a minimum of two coated panels for the material.

⁵ Hipkins, C. C., and Phain, R. J., "The Falling Sand Abrasion Tester," *ASTM Bulletin*, No. 143, December 1946, pp. 18–22.