



Designation: D2711 – 17

## Standard Test Method for Demulsibility Characteristics of Lubricating Oils<sup>1</sup>

This standard is issued under the fixed designation D2711; the number immediately following the designation indicates the year of original adoption or, in the case of revision, the year of last revision. A number in parentheses indicates the year of last reapproval. A superscript epsilon ( $\epsilon$ ) indicates an editorial change since the last revision or reapproval.

### 1. Scope\*

1.1 This test method covers the measurement of the ability of oil and water to separate from each other. It is intended for use in testing medium and high-viscosity lubricating oils.

1.2 The values stated in SI units are to be regarded as standard. No other units of measurement are included in this standard.

1.3 *This standard does not purport to address all of the safety concerns, if any, associated with its use. It is the responsibility of the user of this standard to establish appropriate safety and health practices and determine the applicability of regulatory limitations prior to use.*

1.4 *This international standard was developed in accordance with internationally recognized principles on standardization established in the Decision on Principles for the Development of International Standards, Guides and Recommendations issued by the World Trade Organization Technical Barriers to Trade (TBT) Committee.*

### 2. Referenced Documents

2.1 *ASTM Standards:*<sup>2</sup>

[D1193 Specification for Reagent Water](#)

[D1796 Test Method for Water and Sediment in Fuel Oils by the Centrifuge Method \(Laboratory Procedure\)](#)

[D4175 Terminology Relating to Petroleum Products, Liquid Fuels, and Lubricants](#)

### 3. Terminology

3.1 *Definitions:*

3.1.1 *demulsibility, n*—in petroleum products, the ability of a mixture of liquids (usually hydrocarbons and water) to separate into its components after the mixture has been vigorously agitated. **D4175**

<sup>1</sup> This test method is under the jurisdiction of ASTM Committee D02 on Petroleum Products, Liquid Fuels, and Lubricants and is the direct responsibility of Subcommittee D02.L0.01 on Metal Removal Fluids and Lubricants.

Current edition approved June 1, 2017. Published June 2017. Originally approved in 1968. Last previous edition approved in 2011 as D2711 – 11. DOI: 10.1520/D2711-17.

<sup>2</sup> For referenced ASTM standards, visit the ASTM website, www.astm.org, or contact ASTM Customer Service at service@astm.org. For *Annual Book of ASTM Standards* volume information, refer to the standard's Document Summary page on the ASTM website.

### 4. Summary of Test Method

4.1 *For Oils That Do Not Contain Extreme Pressure (EP) Additives*—A 405 mL sample of the oil and 45 mL of distilled water are stirred together for 5 min at 82 °C in a special graduated separatory funnel. After a 5 h settling period following the stirring, a percentage of the water in the oil and the volumes of water and emulsion separating from the oil are measured and recorded.

4.2 *For Oils That Contain Extreme Pressure (EP) Additives*—A 360 mL sample of the oil and 90 mL of distilled water are stirred together for 5 min at 82 °C in a special graduated separatory funnel. After a 5 h settling period following the stirring, percentage of water in the oil and the volumes of water and emulsion separating from the oil are measured and recorded.

### 5. Significance and Use

5.1 This test provides a guide for determining the demulsibility characteristic of lubricating oils that are prone to water contamination and may encounter the turbulence of pumping and circulation capable of producing water-in-oil emulsions.

### 6. Apparatus

6.1 *Stirrer*, constructed from parts shown in [Figs. 1-3](#).

NOTE 1—An air pressure driven motor is suggested to avoid any potential electrical sparking hazard.

6.2 *Special Graduated Separatory Funnel*, as shown in [Fig. 4](#).

6.3 *Heating Bath*, sufficiently large and deep to permit the immersion of at least two test separatory funnels in the bath liquid up to their 500 mL graduation mark. The bath shall be capable of maintaining a temperature of 82 °C  $\pm$  1 °C and shall be so equipped to hold the separatory funnels securely in a position so that the vertical axis of the stirrer corresponds to the center line of the separatory funnel during the mixing of the oil and water.

NOTE 2—The use of silicone oil as a bath medium is discouraged, since any contamination into the oil/water mixture may cause erroneous results.

6.4 *Centrifuge*, as described in Test Method [D1796](#).

6.5 *Centrifuge Tubes*, long-form, 195 mm to 203 mm as described in [Fig. 1](#) of Test Method [D1796](#).

\*A Summary of Changes section appears at the end of this standard

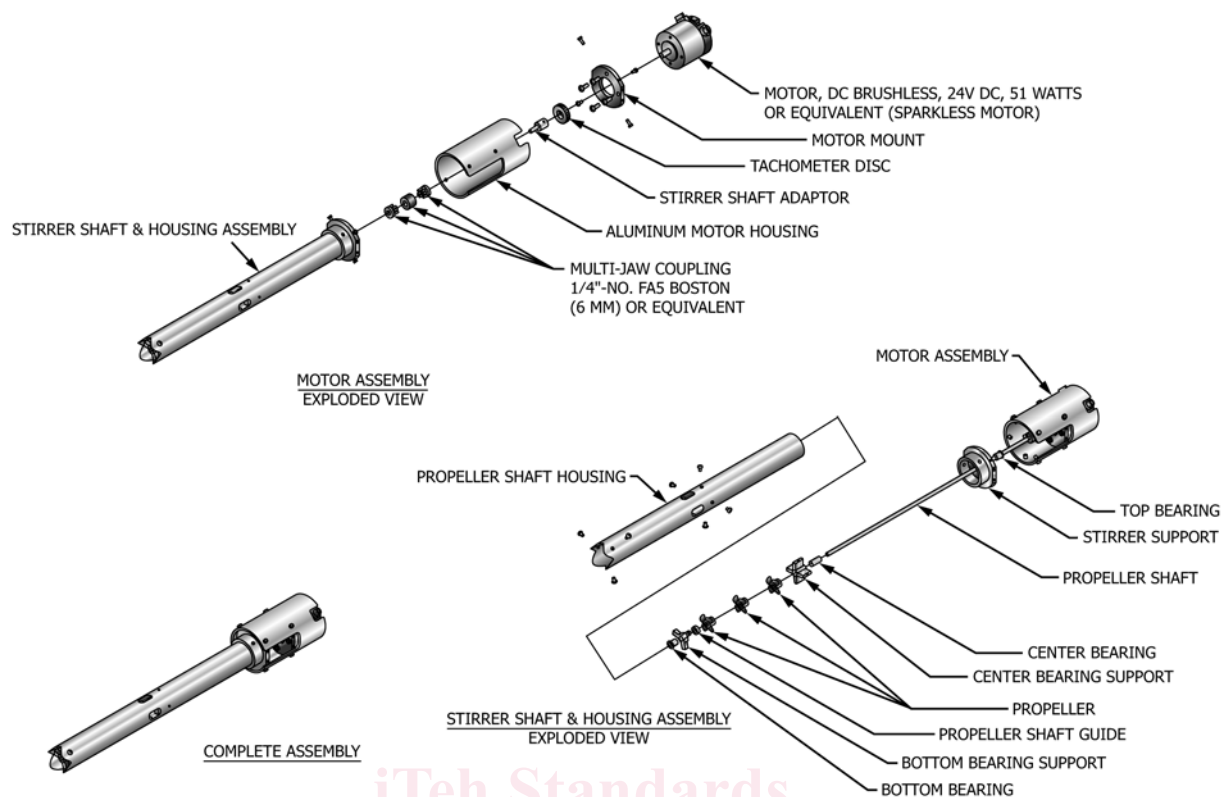

FIG. 1 Stirrer

## 7. Materials

7.1 *Cleaning Solvent*—Any suitable solvent capable of cleaning and effectively removing any oil or fluid from the stirrer and graduated cylinder. 1,1,1-Trichloroethane has been found suitable for use in this test method. (**Warning**—1,1,1-Trichloroethane, Harmful if inhaled or swallowed. Eye irritant. High concentration can cause unconsciousness or death.)

NOTE 3—In cases in which the use of 1,1,1 trichloroethane is unacceptable, some laboratories are using heptane or mineral spirits as alternative solvents. The effect on the precision of this test method when using an alternate solvent has not been determined.

7.2 *Water*—Type II reagent grade water conforming to Specification D1193.

## 8. Preparation of Apparatus

8.1 Clean the graduated separatory funnel by removing any film of oil with cleaning solvent followed by a wash first with acetone (**Warning**—Extremely flammable vapors may cause flash fires. Use of a sparkless motor recommended) and then with tap water. Rinse thoroughly with tap water and then with reagent grade water.

8.2 Clean the stirrer by appropriate means, using the cleaning solvent (7.1). Allow the stirrer to air dry completely prior to use in the test. (**Warning**—To minimize any potential sparking hazard, ensure that the motor is detached from any electrical source during the cleaning procedure.)

## 9. Procedure A for Oils That Do Not Contain EP Additives

9.1 Heat the bath liquid to  $82\text{ }^{\circ}\text{C} \pm 1\text{ }^{\circ}\text{C}$  and maintain this temperature throughout the test.

9.2 Measure the oil under test, at room temperature, directly into the separatory funnel to a volume of  $405\text{ mL} \pm 5\text{ mL}$ . Place the separatory funnel and oil in the constant-temperature bath and bring it to a temperature of  $82\text{ }^{\circ}\text{C}$ . Add  $45\text{ mL} \pm 0.5\text{ mL}$  of distilled water, measured at room temperature, to the oil. Immerse the stirrer in the oil and position it carefully as follows: lower the stirrer until it touches the bottom of the funnel, then raise it approximately 25 mm. Ensure that the vertical axis of the stirrer corresponds with the vertical center line of the funnel. Slowly bring the stirrer motor to a speed of  $4500\text{ r/min} \pm 500\text{ r/min}$  within 25 s to 30 s, and operate for a total of 5 min, including the start-up time. Then withdraw the stirrer from the oil-water mixture but not entirely out of the separatory funnel. Allow the stirrer to drain for 5 min, then remove from the separatory funnel and clean.

NOTE 4—It is critical that silicone grease not be used on the stopcock. Use either PTFE (polytetrafluoroethylene) stopcocks, or use the test oil or other non-silicone containing material as the lubricant for the stopcock.

NOTE 5—Starting the stirrer any more quickly than suggested may cause erroneous results.

9.3 Five hours after stirring has stopped, withdraw a 50 mL sample from the center of the funnel and approximately 50 mm below the surface of the oil-water mixture, using a 50 mL

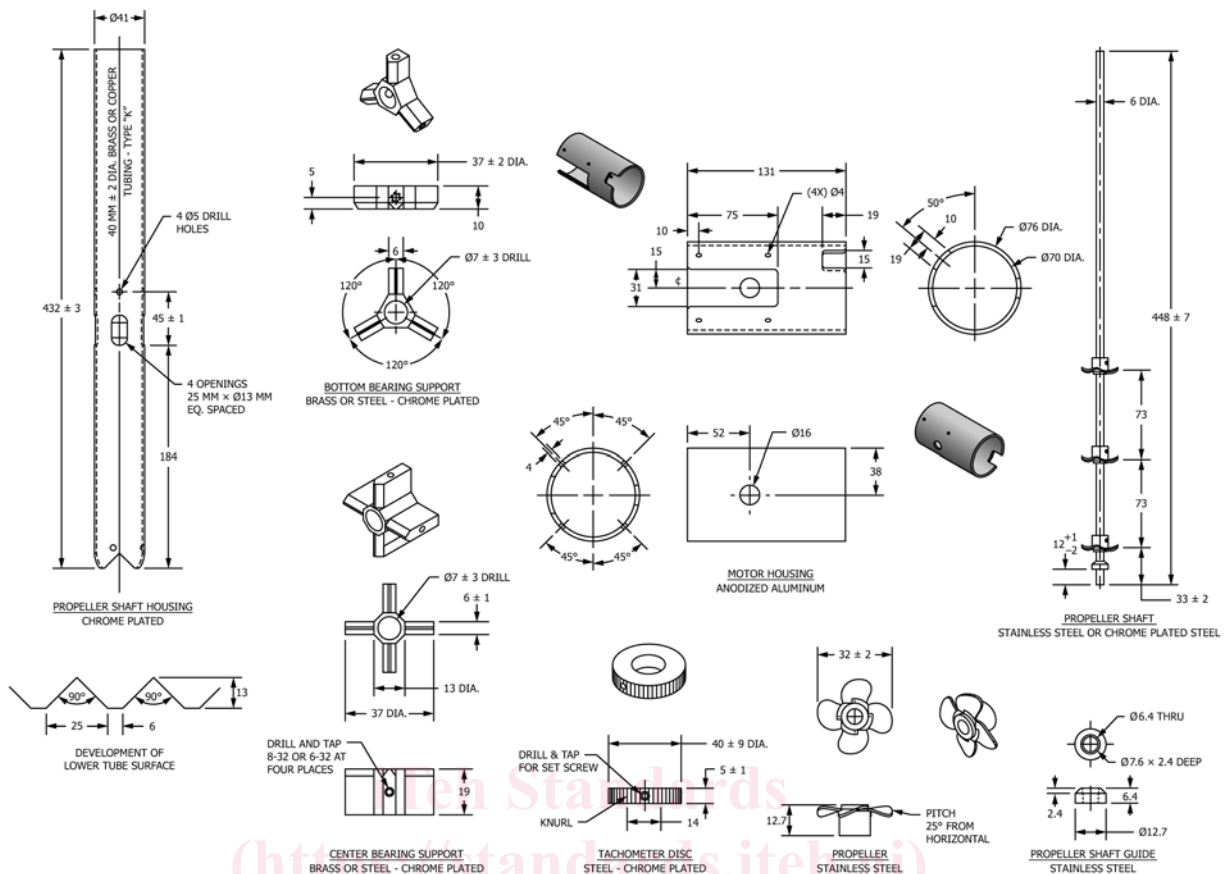

NOTE 1—All dimensions are in millimetres.

FIG. 2 Detailed Construction of Stirrer, Part 1

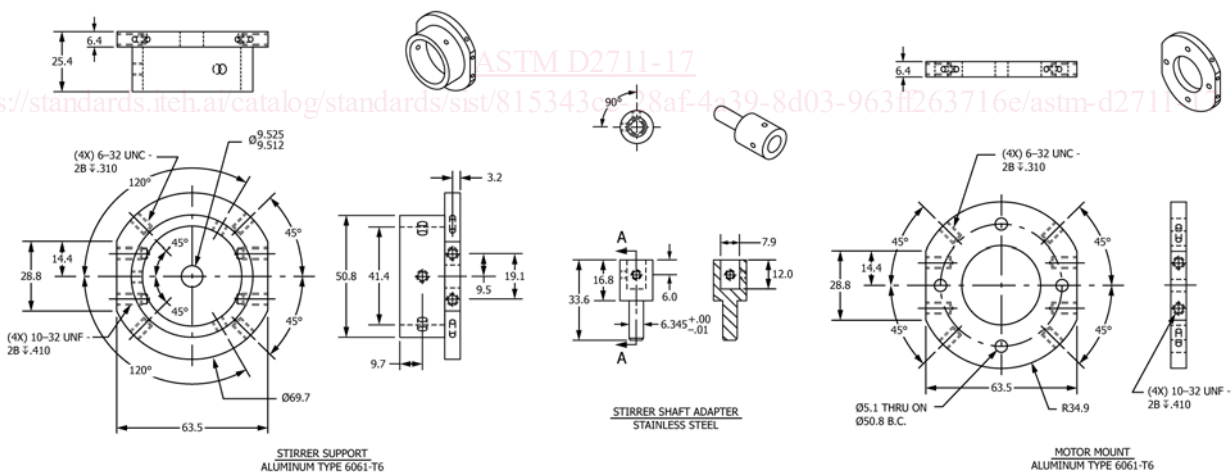

NOTE 1—All dimensions are in millimetres.

FIG. 3 Detailed Construction of Stirrer, Part 2

pipet. Discharge the contents of the pipet into a centrifuge tube and determine the water present in the sample using Test Method D1796. Record the volume of water in the centrifuge tube.

9.4 With minimum delay, remove the separatory funnel from the bath and draw off any free water that has separated

from the oil-water mixture into a 50 mL graduated cylinder. Allow this water to reach room temperature, measure, and record the volume.

9.5 After removing the free water from the separatory funnel, reduce the volume of the fluid remaining to 100 mL by carefully siphoning the fluid off the top (end of siphon should

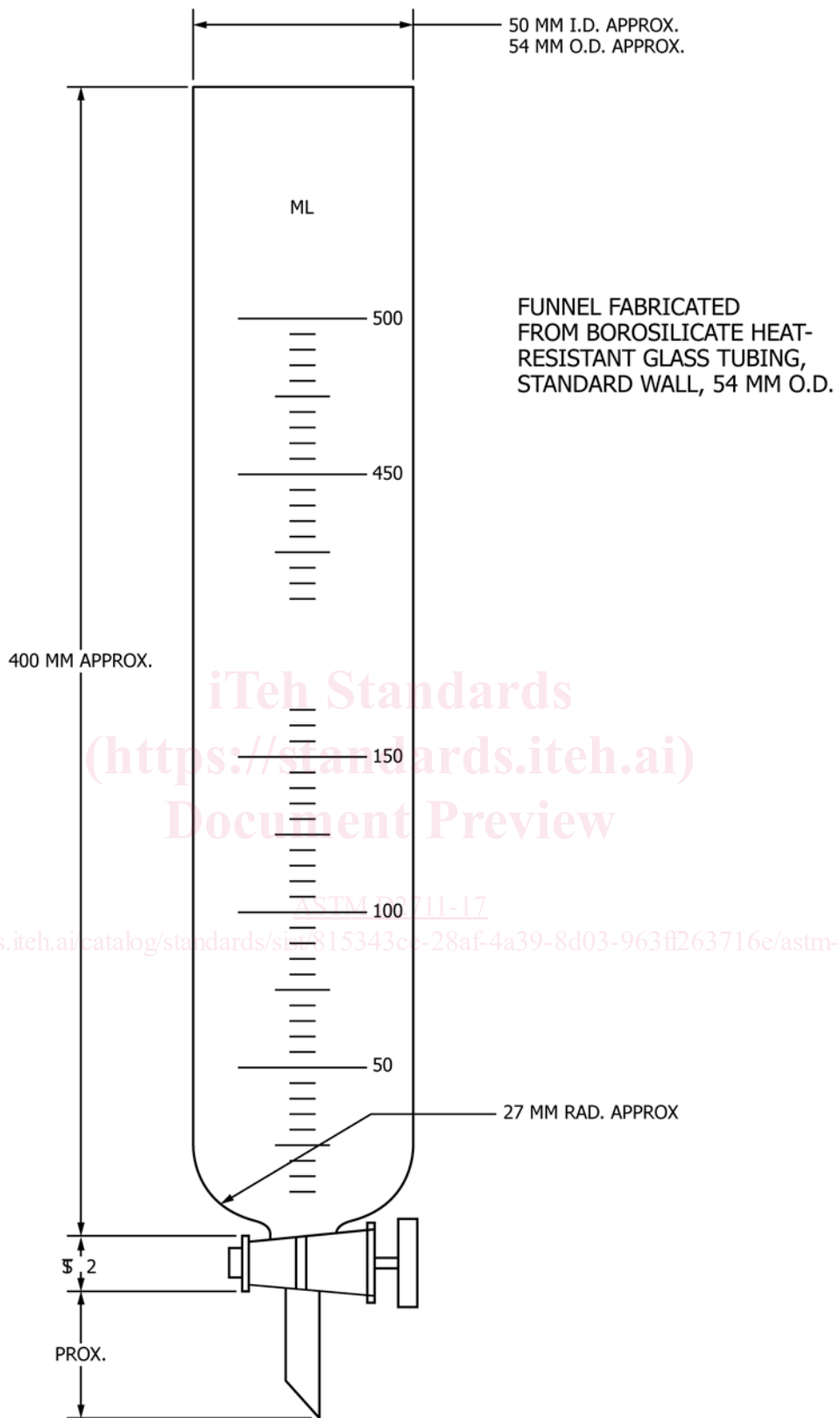

NOTE 1—Stopcock placed as close to tube body as possible.  
**FIG. 4 Graduated Separatory Funnel**