



Designation: D6184 – 17

Standard Test Method for Oil Separation from Lubricating Grease (Conical Sieve Method)¹

This standard is issued under the fixed designation D6184; the number immediately following the designation indicates the year of original adoption or, in the case of revision, the year of last revision. A number in parentheses indicates the year of last reappraisal. A superscript epsilon (ϵ) indicates an editorial change since the last revision or reappraisal.

This standard has been approved for use by agencies of the U.S. Department of Defense.

INTRODUCTION

The conical sieve method for measuring leakage from lubricating grease (commonly known as the cone bleed test) uses the same equipment as the obsolete, withdrawn FED-STD-791C (Federal Test Method (FTM) 791C) Method 321.3, Oil Separation from Lubricating Grease (Static Technique). Despite the lack of a precision statement, Method 321.3 was used for many years in specifications to evaluate the tendencies of base fluid separation from military and industrial greases. Test Method D6184 supersedes the FTM method by overcoming deficiencies of Method 321.3. It includes the procedures and precision determinations resultant from a cooperative study conducted by participating members of Subcommittee D02.G0.

1. Scope*

1.1 This test method covers the determination of the tendency of lubricating grease to separate oil at an elevated temperature. This test method shall be conducted at 100 °C for 30 h unless other conditions are required by the grease specification.

1.2 This test method can be used on any grease with a worked penetration (Test Methods **D217**) greater than 220 mm/10 (NLGI Consistency Number 3 or softer). However, no precision data exists for greases with a penetration greater than 340 mm/10 (softer than NLGI Consistency Number 1).

1.3 The values stated in SI units are to be regarded as standard. The term 60 mesh is used to describe the wire mesh used. This unit was described in the withdrawn **E437** standard and there is no exact metric equivalent.

1.4 *This standard does not purport to address all the safety concerns, if any, associated with its use. It is the responsibility of the user of this standard to establish appropriate safety practices and determine the applicability of regulatory limitations prior to use.*

1.5 *This international standard was developed in accordance with internationally recognized principles on standardization established in the Decision on Principles for the*

Development of International Standards, Guides and Recommendations issued by the World Trade Organization Technical Barriers to Trade (TBT) Committee.

2. Referenced Documents

2.1 *ASTM Standards:*²

D217 Test Methods for Cone Penetration of Lubricating Grease

D1742 Test Method for Oil Separation from Lubricating Grease During Storage

E437 Specification for Industrial Wire Cloth and Screens (Square Opening Series) (Discontinued 2000) Replaced by **E 2016** (Withdrawn 2000)³

2.2 *Government Standard (Withdrawn):*

FED-STD-791C Lubricants, Liquid Fuels, and Related Products; Methods of Testing, Method 321.3 “Oil Separation from Lubricating Greases (Static Technique),” Withdrawn November 2007⁴

3. Terminology

3.1 *Definitions:*

3.1.1 *lubricating grease, n*—a semifluid to solid product of a dispersion of a thickener in a liquid lubricant.

¹ This test method is under the jurisdiction of ASTM Committee **D02** on Petroleum Products, Liquid Fuels, and Lubricants and is the direct responsibility of Subcommittee **D02.G0.03** on Physical Tests

Current edition approved May 1, 2017. Published June 2017. Originally approved in 1997. Last previous edition approved in 2016 as D6184 – 16. DOI: 10.1520/D6184-17.

² For referenced ASTM standards, visit the ASTM website, www.astm.org, or contact ASTM Customer Service at service@astm.org. For *Annual Book of ASTM Standards* volume information, refer to the standard’s Document Summary page on the ASTM website.

³ The last approved version of this historical standard is referenced on www.astm.org.

⁴ Available online at ASSIST Quick Search (<http://quicksearch.dla.mil>).

***A Summary of Changes section appears at the end of this standard**

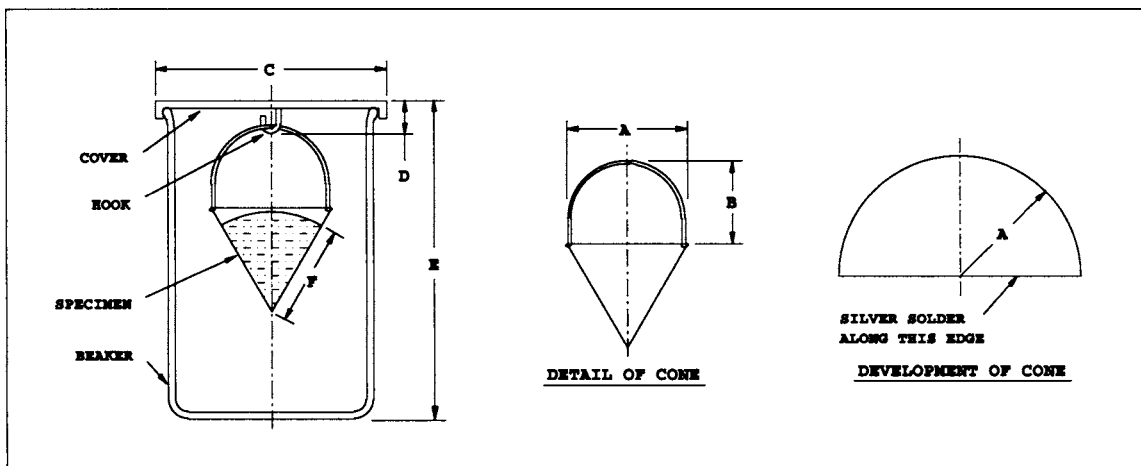

NOTE 1—Dimensions are provided in millimetres (with in./lb. units in parentheses) as follows:

A - 38.1 ± 0.3	(1.50 ± 0.01)	radius
B - 27.0 ± 0.3	(1.06 ± 0.01)	height
C - 70	(2.8)	approximately (to fit beaker)
D - 9.7 ± 3.3	(0.38 ± 0.13)	length
E - 100	(4)	approximately
F - 36	(1.4)	approximately

FIG. 1 Cone Fabrication and Test Setup

3.1.1.1 *Discussion*—The dispersion of the thickener forms a two-phase system and immobilizes the liquid lubricant by surface tension and other physical forces. Other ingredients imparting special properties are often included. **D217**

3.1.2 *oil separation, n*—the appearance of a liquid fraction from an otherwise homogeneous lubricating composition. **D1742**

3.1.3 *thickener, n—in a lubricating grease*, a substance composed of finely divided particles dispersed in a liquid lubricant to form the product's structure.

3.1.3.1 *Discussion*—The thickener can be fibers (such as various metallic soaps) or plates or spheres (such as certain non-soap thickeners) which are insoluble or, at most, only very slightly soluble in the liquid lubricant. The general requirements are that the solid particles be extremely small, uniformly dispersed, and capable of forming a relatively stable, gel-like structure with the liquid lubricant **D217**

4. Summary of Test Method

4.1 The weighed sample is placed in a cone-shaped, wire-cloth sieve, suspended in a beaker, then heated under static conditions for the specified time and temperature. Unless otherwise required by the grease specification, the sample is tested at standard conditions of $100\text{ }^\circ\text{C} \pm 0.5\text{ }^\circ\text{C}$ for $30\text{ h} \pm 0.25\text{ h}$. The separated oil is weighed and reported as a percentage of the mass of the starting test sample.

5. Significance and Use

5.1 When lubricating grease separates oil, the residual material may change in consistency, which can affect the ability of the product to function as designed. Test results obtained with this procedure are not intended to predict oil separation tendencies of grease under dynamic service conditions.

5.2 This test method is used for specifications and quality control.

6. Apparatus

6.1 *Test Apparatus*—The assembled apparatus consists of a cone-shaped sieve constructed of 60 mesh, corrosion-resistant wire cloth, a 200 mL tall-form beaker without spout, and a closely fitting cover with a hook in the center. Construction details and dimensions are shown in Fig. 1.

6.1.1 The conical sieve shall be fabricated of stainless steel, monel, or nickel wire cloth, of No. 60 medium-heavy mesh as defined in Table 2 of Specification E437 and shall be fabricated to the dimensions and requirements shown in Fig. 1.

NOTE 1—Sieves of stapled or wire-bound construction, instead of silver-soldered construction, have been used in the past. Such sieves do not conform to this test method.

6.2 *Oven*, capable of maintaining the specified temperature, $100\text{ }^\circ\text{C} \pm 0.5\text{ }^\circ\text{C}$.

6.3 *Balance*, having a minimum capacity of 250 g and a sensitivity of at least 0.01 g.

7. Sampling

7.1 Examine the sample for any indication of non-homogeneity such as oil separation, phase changes, or gross contamination. If any abnormal conditions are found, obtain a new sample.

7.2 The sample submitted for analysis should be minimally sufficient for duplicate testing.

7.3 Although the mass of the test grease is determined, the sieve is filled by volume rather than mass. Each test will require a quantity sufficient to fill the sieve to approximately