



Designation: **D5801—12 D5801 – 17**

Standard Test Method for Toughness and Tenacity of Bituminous Asphalt Materials¹

This standard is issued under the fixed designation D5801; the number immediately following the designation indicates the year of original adoption or, in the case of revision, the year of last revision. A number in parentheses indicates the year of last reapproval. A superscript epsilon (ϵ) indicates an editorial change since the last revision or reapproval.

1. Scope

1.1 This test method describes the procedure for measuring the toughness and tenacity of bituminous asphalt materials. Typically, the test method has been used to characterize elastomer modified asphalts, although values for toughness and tenacity may be obtained for any type of polymer-modified or non-modified asphalt.

1.2 The values stated in inch-pound units are to be regarded as standard. The values given in parentheses are mathematical conversions to SI units that are provided for information only and are not considered standard.

1.2.1 *Exception*—Sample mass is given only in SI units. Sample mass as given in SI units should be regarded as standard. No other units of sample mass are included in this standard.

1.3 **Warning**—Mercury has been designated by the United States Environmental Protection Agency and many state agencies as a hazardous material that can cause central nervous system, kidney, and liver damage. Mercury, or its vapor, may be hazardous to health and corrosive to materials. Caution should be taken when handling mercury and mercury containing products. See the applicable Material Safety Data Sheet (MSDS) for details and EPA's website – <http://www.epa.gov/mercury/index.htm> — for additional information. Users should be aware that selling mercury and/or mercury-containing mercury-containing products ~~in~~ in your state may be prohibited by state law.

1.4 The text of this standard references notes and footnotes which provide explanatory material. These notes and footnotes (excluding those in tables and figures) shall not be considered as requirements of the standard.

1.5 *This standard does not purport to address all of the safety concerns, if any, associated with its use. It is the responsibility of the user of this standard to establish appropriate safety and health practices and determine the applicability of regulatory limitations prior to use.*

1.6 *This international standard was developed in accordance with internationally recognized principles on standardization established in the Decision on Principles for the Development of International Standards, Guides and Recommendations issued by the World Trade Organization Technical Barriers to Trade (TBT) Committee.*

2. Referenced Documents

2.1 *ASTM Standards:*²

[D5 Test Method for Penetration of Bituminous Materials](#)

[D1754 Test Method for Effects of Heat and Air on Asphaltic Materials \(Thin-Film Oven Test\)](#)

[D2872 Test Method for Effect of Heat and Air on a Moving Film of Asphalt \(Rolling Thin-Film Oven Test\)](#)

[D3666 Specification for Minimum Requirements for Agencies Testing and Inspecting Road and Paving Materials](#)

[E1 Specification for ASTM Liquid-in-Glass Thermometers](#)

[E77 Test Method for Inspection and Verification of Thermometers](#)

[E644 Test Methods for Testing Industrial Resistance Thermometers](#)

[E1137/E1137M Specification for Industrial Platinum Resistance Thermometers](#)

[E2251 Specification for Liquid-in-Glass ASTM Thermometers with Low-Hazard Precision Liquids](#)

¹ This test method is under the jurisdiction of ASTM Committee D04 on Road and Paving Materials and is the direct responsibility of Subcommittee D04.44 on Rheological Tests.

Current edition approved Dec. 1, 2012; June 1, 2017. Published May 2013; June 2017. Originally approved as Proposal P 243 in 1994. Last previous edition approved in 2006; 2012 as [D5801—95 \(2006\) D5801 – 12](#).¹ DOI: [10.1520/D5801-12](https://doi.org/10.1520/D5801-12); [10.1520/D5801-17](https://doi.org/10.1520/D5801-17).

² For referenced ASTM standards, visit the ASTM website, www.astm.org, or contact ASTM Customer Service at service@astm.org. For *Annual Book of ASTM Standards* volume information, refer to the standard's Document Summary page on the ASTM website.

3. Summary of Test Method

3.1 A tension head of specified size and shape is pulled from an asphalt sample at a rate of 20 in./min (508 mm/min). A continuous record of the ~~force-versus-elongation~~ ~~force-versus-elongation~~ curve is made and used to calculate the toughness and the tenacity of the sample. The test is run at room temperature $77 \pm 5^\circ\text{F}$ ($25 \pm 3^\circ\text{C}$), 3 °C, after the sample has been subjected to a specified temperature history.

3.2 Toughness is defined in this procedure as the total work required to completely separate the tension head from the sample under the specified test conditions. Tenacity is a measure of the increasing force as the sample is stretched past the initial peak, and may indicate the type and amount of polymer used to modify the asphalt. It is defined as the work required to stretch the material after the initial resistance is overcome.

4. Significance and Use

4.1 This test method is useful in confirming that an asphalt cement has been modified with a material that provides a significant elastomeric component. ~~Elastomer-modified~~ ~~Elastomer-modified~~ asphalts can be characterized by their ability to be stretched to a large elongation while at the same time resisting further stretching. Toughness and tenacity are two parameters for measuring this ability.

NOTE 1—The quality of the results produced by this standard are dependent on the competence of the personnel performing the procedure and the capability, calibration, and maintenance of the equipment used. Agencies that meet the criteria of Specification D3666 are generally considered capable of competent and objective testing, sampling, inspection, etc. Users of this standard are cautioned that compliance with Specification D3666 alone does not completely ensure reliable results. Reliable results depend on many factors: following the suggestions of Specification D3666 and or some similar acceptable guideline provides a means of evaluating and controlling some of those factors.

5. Apparatus

5.1 *Sample Container*—A metal, cylindrical, ~~flat-bottom~~ ~~flat-bottom~~ container with a nominal inside diameter of 2 $\frac{1}{8}$ in. (54.0 mm) and a nominal depth of 1 $\frac{3}{8}$ in. (34.9 mm) shall be used to hold the sample. Containers known as tin boxes or seamless ointment boxes with a 3-oz capacity meet these requirements.

5.2 *Tension Head*—The tension head shall consist of a polished metal, hemispherical head with a $\frac{7}{16}$ in. (11.1 ~~mm~~) mm radius, which is integrally connected to a $\frac{1}{4}$ in. (6.4 mm) diameter stem approximately 1 $\frac{5}{16}$ in. (33.3 mm) long. The stem shall be threaded and fitted with a knurled lowering screw to allow for accurate adjustment of the tension head height in the sample container. The stem of the tension head shall be fitted with a small pin to prevent twisting of the head while adjusting the height. Dimensions of the tension head are shown in Fig. 1.

NOTE 2—Brass and stainless steel are acceptable metals for constructing tension heads. Aluminum scratches easily and steel rusts, so these metals should not be used.

5.3 *Spider*—The support for the tension head shall consist of a cylindrical center section through which the stem of the tension head may freely move parallel to the axis of the cylinder. The inner wall of the cylinder shall be grooved to receive the pin mounted on the stem of the tension head. The spider cylinder shall be fitted with three arms, equally spaced at ~~120 degrees~~, 120°, extending from the center and notched to receive the lip of the sample container, thereby centering the spider and tension head in the sample container. Details of the spider construction are shown in Fig. 2.

5.4 *Testing Machine*—Any tensile tester capable of pulling the tension head at a uniform rate of 20 in./min (508 mm/min), and recording the ~~force-versus-elongation~~ ~~force-versus-elongation~~ curve, may be used. The accuracy of the pull rate shall be $\pm 2\%$ or better. The maximum load capacity shall be at least 100 lb (45.4 kg). If ~~polymer-modified~~ ~~polymer-modified~~ asphalts are to be tested after conditioning in the thin film oven per Test Method D1754 or the rolling thin film oven per Test Method D2872, higher load capacities are needed. A maximum load capacity of 200 lb (90.7 kg) is suggested for ~~age-conditioned~~ ~~age-conditioned~~ asphalt binder.

5.4.1 The tensile tester must be equipped to hold the sample container firmly in place while the tension head is pulled away. The details of this sample holder will vary with the type of tester used. The tester must have a minimum effective pull length of 24 in. (609.6 mm) after installing the sample holder.

5.5 *Water Bath*—A bath capable of maintaining a temperature of $77 \pm 0.2^\circ\text{F}$ (0.2°F) ($25 \pm 0.1^\circ\text{C}$) (0.1°C) is required. The bath shall have a perforated shelf supported in a position not less than ~~2 in.~~ 2 in. (50.8 mm) from the bottom and not less than 4 in. (~~101.6 mm~~) (101.6 mm) below the liquid level.

5.6 *Oven*—An oven capable of maintaining a temperature of $325 \pm 10^\circ\text{F}$ (10°F) ($162.8 \pm 5.6^\circ\text{C}$) (5.6 °C) shall be used to heat the samples.

5.7 *Thermometer*—A thermometer for monitoring the temperature of the water bath. The thermometer shall be one of the following:

5.7.1 A liquid-in-glass thermometer of suitable range with subdivisions and maximum scale error of 0.2°F (0.1°C) (0.2 °F) (0.1 °C) which conforms to the requirements of Specification E1. The thermometer shall be standardized in accordance with one of the methods in Test Method E77.

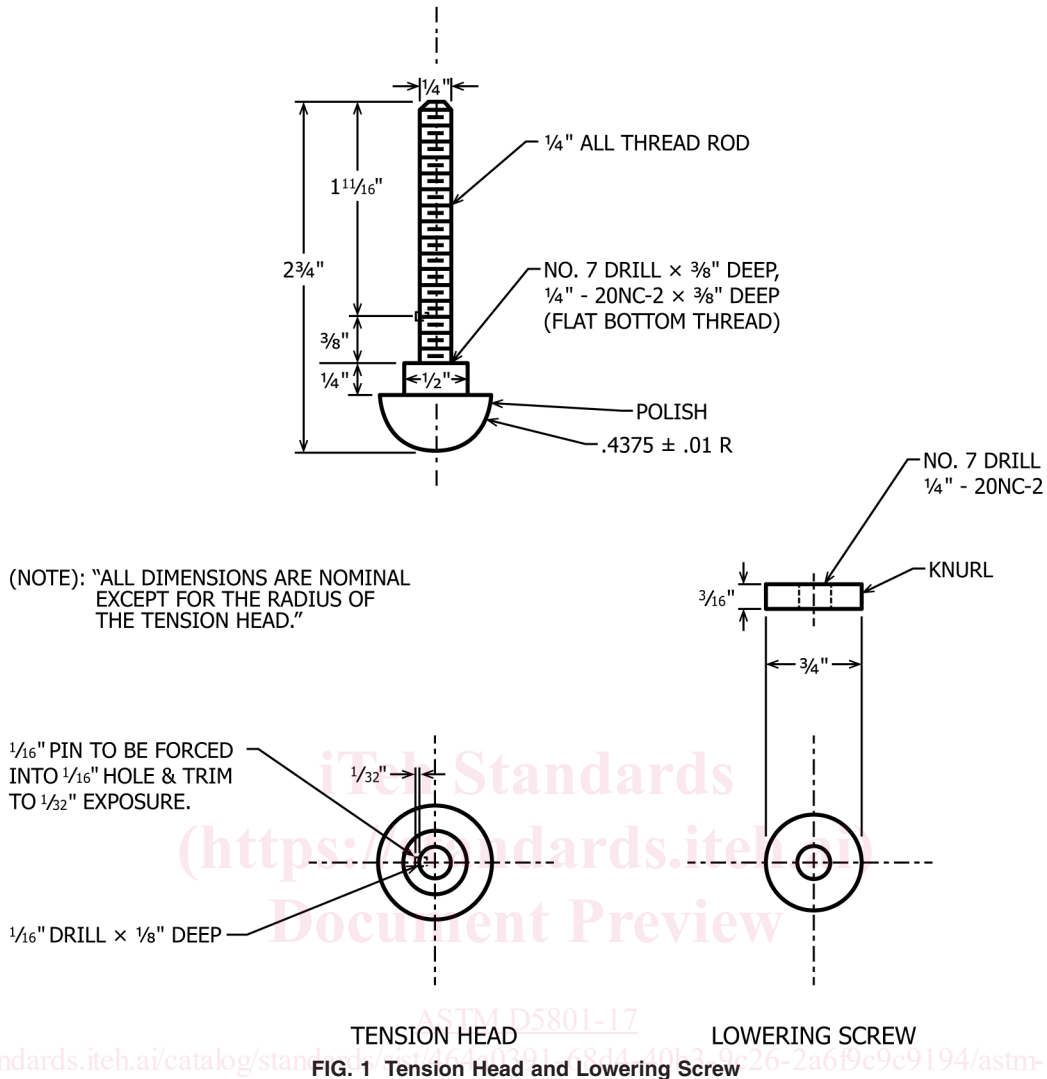

FIG. 1 Tension Head and Lowering Screw

5.7.2 A liquid-in-glass thermometer of suitable range with subdivisions and maximum scale error of 0.2°F (0.1°C) 0.2°F (0.1°C) which conforms to the requirements of Specification E2251. The thermometer shall be standardized in accordance with one of the methods in Specification Test Method E77.

5.7.3 A platinum resistance thermometer (PRT) with a probe which conforms to the requirements of Specification E1137/E1137M. The PRT shall have a 3- or 4-wire configuration and the overall sheath length shall be at least 2 in. (50.8 mm) greater than the immersion depth. The PRT system (probe and readout) shall be standardized in accordance with Test Methods E644. Corrections shall be applied to ensure measurements within 0.2°F (0.1°C) 0.2°F (0.1°C).

5.7.4 A metal-sheathed thermistor with a sensor substantially similar in construction to the PRT probe described in 5.7.3. The thermistor system (sensor and readout) shall be standardized in accordance with Test Methods E644. Corrections shall be applied to ensure measurements within 0.2°F (0.1°C) 0.2°F (0.1°C).

NOTE 3—In those cases where the samples are conditioned in the standard penetration bath, the thermometer as prescribed for Test Method D5 may be used.

6. Sample Preparation

6.1 Bring the sample to a temperature where it is sufficiently fluid to pour, as described in the following paragraphs.

6.1.1 If the sample is at room temperature, place the sample in a loosely covered container in an oven at 325°F (162.8°C) $325 \pm 10^{\circ}\text{F}$ ($162.8 \pm 5.6^{\circ}\text{C}$) until the sample is at a uniform temperature and sufficiently fluid to pour. Take care to prevent local overheating of the sample.

6.1.2 If the sample is a residual product from an emulsion distillation test and is already hot, carefully stir the contents in the still and immediately pour into containers, as described in the following paragraphs.

6.2 Carefully stir the sample, without incorporating any air bubbles, until the sample is homogenous.