



Designation: ~~D1461 – 11~~ D1461 – 17

## Standard Test Method for Moisture or Volatile Distillates in Bituminous Paving Asphalt Mixtures<sup>1</sup>

This standard is issued under the fixed designation D1461; the number immediately following the designation indicates the year of original adoption or, in the case of revision, the year of last revision. A number in parentheses indicates the year of last reapproval. A superscript epsilon ( $\epsilon$ ) indicates an editorial change since the last revision or reapproval.

*This standard has been approved for use by agencies of the U.S. Department of Defense.*

### 1. Scope

1.1 This test method covers the determination, by direct measurement, of moisture or volatile fractions of the ~~bitumen asphalt~~ in ~~bituminous paving asphalt~~ mixtures.

1.2 The values stated in SI units are to be regarded as the standard. ~~The values given in parentheses are for information only.~~ No other units of measurement are included in this standard.

1.3 The text of this standard references notes and footnotes which provide explanatory material. These notes and footnotes (excluding those in tables and figures) shall not be considered as requirements of the standard.

1.4 *This standard does not purport to address all of the safety concerns, if any, associated with its use. It is the responsibility of the user of this standard to establish appropriate safety and health practices and determine the applicability of regulatory limitations prior to use.*

1.5 *This international standard was developed in accordance with internationally recognized principles on standardization established in the Decision on Principles for the Development of International Standards, Guides and Recommendations issued by the World Trade Organization Technical Barriers to Trade (TBT) Committee.*

### 2. Referenced Documents

2.1 ASTM Standards:<sup>2</sup>

~~D979~~ D979/D979M Practice for Sampling Bituminous Paving Mixtures

D3666 Specification for Minimum Requirements for Agencies Testing and Inspecting Road and Paving Materials

D6997 Test Method for Distillation of Emulsified Asphalt

### 3. Significance and Use

3.1 This test method is used for determining either the amount of moisture or the amount of volatile petroleum distillates in ~~bituminous paving asphalt~~ mixtures.

3.2 Applicable standards are those in which measurements or calibrations are made, samples are procured, or products are selected.<sup>3</sup>

### 4. Apparatus

4.1 *Metal Still*—A vertical cylindrical still, similar to that used in Test Methods Method D6997, having a faced flange at the top to which the head is tightly attached by means of a clamp. The head shall be of metal, preferably of copper or brass, and shall have a tube opening of 25.4 mm (~~1 in~~) of inside diameter to facilitate attachment of the specified trap/condenser assembly.

<sup>1</sup> This test method is under the jurisdiction of ASTM Committee D04 on Road and Paving Materials and is the direct responsibility of Subcommittee D04.25 on Analysis of Asphalt Mixtures.

Current edition approved Dec. 15, 2011; June 1, 2017. Published December 2011; June 2017. Originally approved in 1956. Last previous edition approved in 2006 as ~~D1461 – 85 (2006)~~ D1461 – 11. DOI: ~~10.1520/D1461-11~~ 10.1520/D1461-17.

<sup>2</sup> For referenced ASTM standards, visit the ASTM website, www.astm.org, or contact ASTM Customer Service at service@astm.org. For *Annual Book of ASTM Standards* volume information, refer to the standard's Document Summary page on the ASTM website.

<sup>3</sup> The quality of the results produced by this standard are dependent on the competence of the personnel performing the procedure and the capacity, calibration, and maintenance of the equipment used. Agencies that meet the criteria of Specification D3666 are generally considered capable of competent and objective testing, sampling, inspection, etc. Users of this standard are cautioned that compliance with Specification D3666 alone does not completely ensure reliable results. Reliable results depend on many factors; following the suggestions of Specification D3666 or some similar acceptable guideline provides a means of evaluating and controlling some of those factors.

4.2 *Condenser*, of the water-cooled reflux glass-tube type, having a condenser jacket not less than 400 mm (15 3/4 in.) long with an inner tube 9.5 to 12.7 mm (3/8 to 1/2 in.) in outside diameter. The end of the condenser inserted in the trap shall be ground off at an angle of 30° from the vertical axis of the condenser. For mixtures with very volatile solvents, it may be necessary to supplement this water-cooled condenser with a second water-cooled condenser of approximately the same dimensions.

4.3 *Trap*, of well-annealed glass, of one of the following types depending upon the purpose of the test:

4.3.1 For determination of water in ~~bituminous paving asphalt~~ mixtures, a glass trap of ~~10~~10- or 25-mL capacity shall be used. The trap shall be graduated in 0.1-mL divisions with ±0.05-mL maximum error below 1 mL, and in 0.2-mL divisions with a ±0.1-mL maximum error above 1 mL, as specified in Table 1 and ~~Fig. 1~~Figs. 1-4, Fig. 2, Fig. 3, and Fig. 4. Tapered Ball traps require adaptors for connection to the metal still.

4.3.2 For determination of the volatile fractions of the ~~bitumen, asphalt~~, the trap shall conform to the dimensions shown in Fig. 5.

4.4 *Solvent*—For general use, an aromatic solvent is preferred, since it has high solvency and dispersing power for most ~~bituminous asphalt~~ materials. Xylene, or a blend of 20 % toluene and 80 % xylene, is recommended. For asphalts and similar petroleum products, a petroleum distillate, 5 % boiling between 90 and ~~100°C~~100 °C, and 90 % distilling below ~~210°C~~210 °C may be used. For ~~coal tar, coal tar~~, water-gas tar, and similar materials, the aromatic solvent must be used.

4.5 *Heating Device*— Any satisfactory source of heat that will be capable of maintaining a rate of distillation of 85 to 95 ~~drops~~ drops/min/min.

## 5. Sampling

5.1 Sampling shall be carried out in accordance with the procedures set forth in Test ~~Methods~~Method ~~D979~~D979/D979M.

5.2 The sample shall be representative of the material and shall be of such size as practical to fill the container in which it is transported to the laboratory. For duplicate tests, a 1.9-L (1/2-gal) friction-top tin pail full of the material would be satisfactory.

## 6. Test Specimen and Sample

6.1 Thoroughly mix the sample and weigh out an amount estimated to show a percentage of moisture or diluent within the capacity of the trap calibration. Keep the remainder of the sample in its tightly covered container. The weighed sample should be preferably not less than 500 g for normal mixtures. Thoroughly break up this sample to avoid larger lumps, and place it in the still.

## 7. Procedure for Determination of Moisture

7.1 After the sample has been placed in the still, add 200 mL of the solvent and quickly stir it into the sample.

7.2 Assemble the components of the apparatus as illustrated in Fig. 6, choosing the trap in accordance with the expected water content of the sample and making all connections vapor and liquid tight. Insert a gasket of heavy paper, moistened with water between the still body and cover. The condenser tube and trap must be chemically clean to ~~assure~~ensure free drainage of water into the bottom of the trap. Insert a loose cotton plug in the tip of the ~~condensor~~condenser to prevent condensation of atmospheric moisture inside it. Circulate cold water through the jacket of the condenser.

7.3 Apply heat at such a rate that refluxing will start within 5 to 10 min after the heat has been applied and the condenser solvent will drip into the trap at a rate of 85 to 95 drops/min. Continue the distillation until three successive readings of the trap at 15-min intervals show no increase in the amount of water being condensed, except that in no case shall distillation continue for more than 1 1/2 h.

7.4 Allow the contents of the trap to reach room temperature and read the volume of water in the trap to the nearest scale division. Record the volume of water and calculate in weight percent as described in 9.1.

TABLE 1 Dimensions and Sizes of Traps

| Style | Description           |                          |                      | Figure | Size of Trap, mL | Range, mL                    | Small-est Scale Division, mL | Scale Error max, mL |
|-------|-----------------------|--------------------------|----------------------|--------|------------------|------------------------------|------------------------------|---------------------|
|       | Top of Graduated Tube | Bottom of Graduated Tube | Bottom of Vapor Tube |        |                  |                              |                              |                     |
| A     | § joint               | conical                  | § joint              | 7      | 10               | 0 to 1.0<br>over 1.0 to 10.0 | 0.1<br>0.2                   | 0.05<br>0.1         |
| B     | § joint               | conical                  | § joint              | 8      |                  |                              |                              |                     |
| C     | § joint               | conical                  | plain                | 9      |                  |                              |                              |                     |
| D     | plain                 | conical                  | plain                | 10     | 25               | 0 to 1.0<br>over 1.0 to 25   | 0.1<br>0.2                   | 0.05<br>0.1         |
| E     | § joint               | round                    | § joint              | 11     | 5<br>10          | 0 to 5.0<br>0 to 10.0        | 0.1<br>0.1                   | 0.05<br>0.1         |

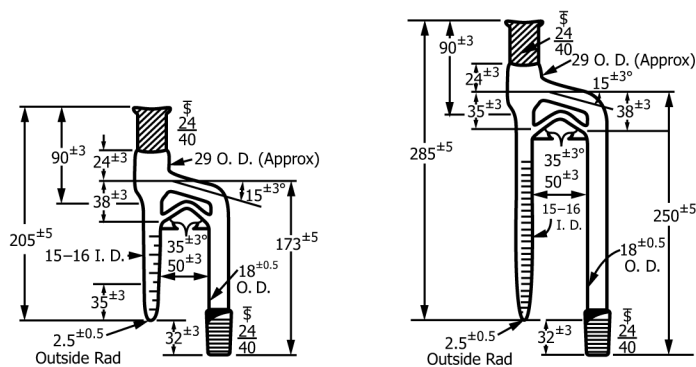

NOTE 1—All dimensions are in millimetres.

FIG. 1 —TrapsTraps (Style A)

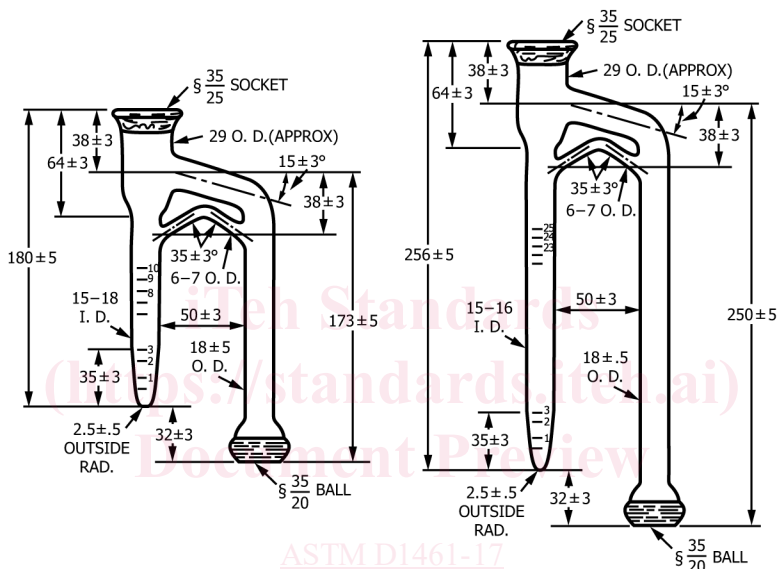

NOTE 1—All dimensions are in millimetres.

FIG. 2 —TrapsTraps (Style B)

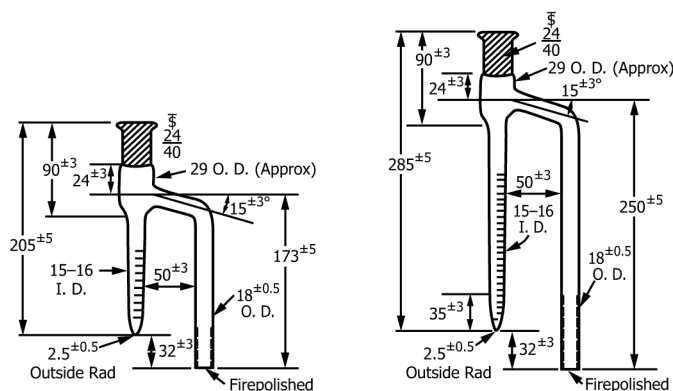

NOTE 1—All dimensions are in millimetres.

FIG. 3 —TrapsTraps (Style C)

## 8. Procedure for Determination of Volatile Distillates

8.1 After the sample has been placed in the still, add 350 mL of water and approximately 3 g of sodium carbonate ( $\text{Na}_2\text{CO}_3$ ) and quickly stir into the sample. Firmly attach the still cover and assemble the trap and condenser in the manner prescribed in 7.2, except that the gasket is moistened with solvent and the trap used shall be the dilution trap specified in 4.3.2.