



Designation: A769/A769M – 17

Standard Specification for Carbon and High-Strength Electric Resistance Forge- Welded Steel Structural Shapes¹

This standard is issued under the fixed designation A769/A769M; the number immediately following the designation indicates the year of original adoption or, in the case of revision, the year of last revision. A number in parentheses indicates the year of last reapproval. A superscript epsilon (ϵ) indicates an editorial change since the last revision or reapproval.

1. Scope*

1.1 This specification covers carbon and high-strength steel shapes of structural quality manufactured by the electric-resistance forge-welding process from coils.

1.2 The size range covered is described in nominal dimensions for columns, beams, and tees.

| | Size Range, in. (mm) |
|------------------|------------------------------|
| Web thickness | 0.060 to 0.500 [1.5 to 12.7] |
| Flange thickness | 0.060 to 0.500 [1.5 to 12.7] |
| Overall depth | 2.00 to 24.00 [50 to 600] |
| Flange width | 0.50 to 12.00 [12.7 to 300] |

1.3 These shapes are intended for two classes of application:

1.3.1 *Class 1*—General structural use where static loading predominates.

1.3.2 *Class 2*—Structural use where fatigue loading occurs and is a principal design consideration.

NOTE 1—**Caution**—Because of the absence of smooth, integral, large radius fillets at the junctions of the webs and the flanges (see Fig. 1), fatigue limits of resistance forge-welded shapes in torsion, lateral loading, and flexure are usually lower than those for hot-rolled shapes of similar size and material. Users should consult shape manufacturers for recommended values of fatigue limits for each specific use, material, and size in cases where dynamic loading is a principal design consideration.

1.4 When the steel is to be welded, it is presupposed that a welding procedure suitable for the grade of steel and intended use or service will be utilized. See Appendix X3 of Specification A6/A6M for information on weldability.

1.5 The values stated in either SI units or inch-pound units are to be regarded separately as standard. The values stated in each system may not be exact equivalents; therefore, each system shall be used independently of the other. Combining values from the two systems may result in non-conformance with the standard.

1.6 The following safety hazards caveat pertains only to the test methods portion, Section 10, of this specification: *This*

standard does not purport to address all of the safety concerns, if any, associated with its use. It is the responsibility of the user of this standard to establish appropriate safety and health practices and determine the applicability of regulatory limitations prior to use.

1.7 *This international standard was developed in accordance with internationally recognized principles on standardization established in the Decision on Principles for the Development of International Standards, Guides and Recommendations issued by the World Trade Organization Technical Barriers to Trade (TBT) Committee.*

2. Referenced Documents

2.1 *ASTM Standards:*²

A6/A6M Specification for General Requirements for Rolled Structural Steel Bars, Plates, Shapes, and Sheet Piling
A370 Test Methods and Definitions for Mechanical Testing of Steel Products

A568/A568M Specification for Steel, Sheet, Carbon, Structural, and High-Strength, Low-Alloy, Hot-Rolled and Cold-Rolled, General Requirements for

A635/A635M Specification for Steel, Sheet and Strip, Heavy-Thickness Coils, Hot-Rolled, Alloy, Carbon, Structural, High-Strength Low-Alloy, and High-Strength Low-Alloy with Improved Formability, General Requirements for

A700 Guide for Packaging, Marking, and Loading Methods for Steel Products for Shipment

2.2 *American Welding Society Standard:*

AWS Specification D 1.1 Structural Welding Code³

3. Ordering Information

3.1 Orders for material under this specification should include the following, as required, to describe the desired material adequately:

3.1.1 Quantity (total number of feet (metres) or lengths),

¹ This specification is under the jurisdiction of ASTM Committee A01 on Steel, Stainless Steel and Related Alloys and is the direct responsibility of Subcommittee A01.02 on Structural Steel for Bridges, Buildings, Rolling Stock and Ships.

Current edition approved June 1, 2017. Published June 2017. Originally approved in 1979. Last previous edition approved in 2010 as A769/A769M – 05 (2010). DOI: 10.1520/A0769_A0769M-17.

² For referenced ASTM standards, visit the ASTM website, www.astm.org, or contact ASTM Customer Service at service@astm.org. For *Annual Book of ASTM Standards* volume information, refer to the standard's Document Summary page on the ASTM website.

³ Available from American Welding Society (AWS), 8669 NW 36 St., #130, Miami, FL 33166-6672, http://www.aws.org.

*A Summary of Changes section appears at the end of this standard

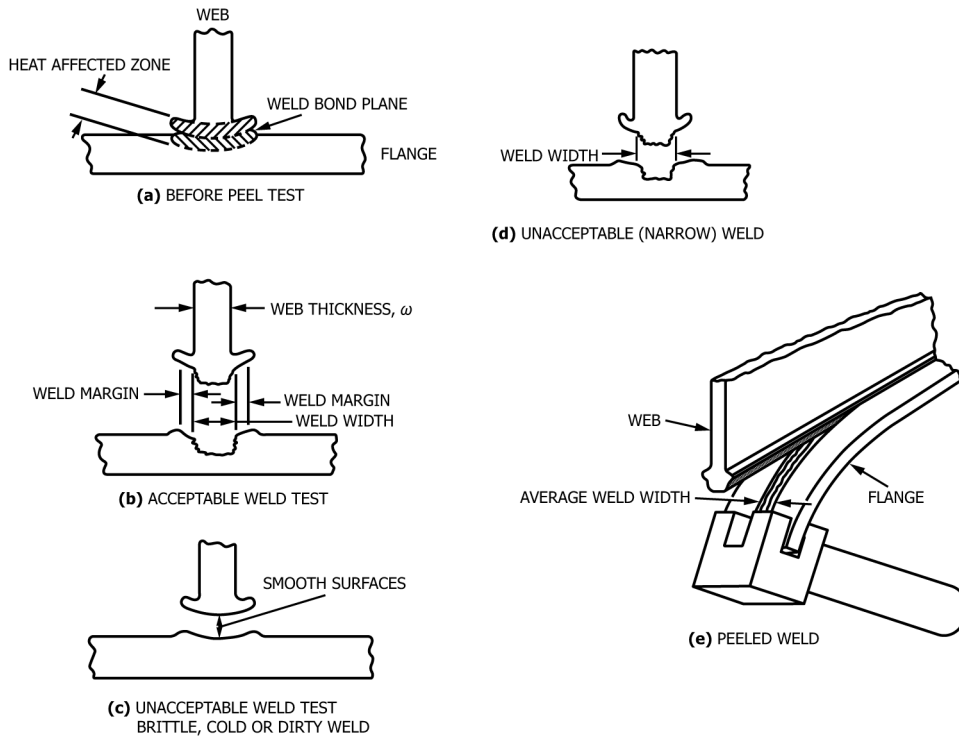

FIG. 1 Appearance of Peel Test Criteria

- 3.2 ASTM designation and year of issue, grade, and class,
- 3.3 Shape and size,
- 3.4 Length of each piece,
- 3.5 Information on intended application,
- 3.6 Other special requirements, and
- 3.7 Required certification and test reports.

4. Materials and Manufacture

4.1 The shapes shall be manufactured from coils by the electric-resistance forge-welding process. All components of a shape shall be furnished to the same grade unless otherwise specified.

4.2 For Class 1 shapes the average width of weld at the joint to the flange shall be more than 110 % of the nominal web thickness (see Fig. 1(b)). The acceptability of coil-splice welds in webs and flanges shall be subject to negotiation between the purchaser and the manufacturer.

4.3 For Class 2 shapes the average width of weld at the joint to the flange shall be more than 130 % of the nominal web thickness (see Fig. 1(b)). Coil-splice welds shall not be permitted.

4.4 Flash caused by welding will not be removed unless indicated on the purchase order.

NOTE 2—Flash is considered to be non-structural.

5. Chemical Composition

5.1 A chemical analysis of each heat of steel shall be made by the steel manufacturer. The chemical composition thus determined shall conform to the requirements of Table 1. The

TABLE 1 Chemical Requirements^A

| General Limitations, % | |
|------------------------|----------------------|
| Carbon | 0.26 max |
| Manganese | 0.30 min to 1.65 max |
| Phosphorus | 0.03 max |
| Sulfur | 0.035 max |
| Silicon | 0.60 max |

^A The choice and use of alloying elements (combined with carbon, manganese, phosphorus, and sulfur within the limits prescribed) to provide the specified mechanical properties, or to enhance the atmospheric corrosion resistance, or both, may vary with manufacturer and thickness of material. The heat analysis, including the alloying elements intentionally added, shall be reported to the purchaser. Permitted variations in product analysis shall be within the limits established in Table A of Specification A6/A6M for plate steel coils or Specification A568/A568M for sheet steel coils.

steel manufacturer shall provide a test report of the heat analysis to the shape manufacturer. Heat analysis reports shall be furnished by the shape manufacturer to the shape purchaser.

5.2 The steel manufacturer, shape manufacturer, and the shape purchaser shall establish a chemical composition, which will assure the purchaser of the desired properties while providing the shape manufacturer with material that is weldable by the electric-resistance welding process.

6. Tension Test

6.1 The material as represented by the test specimen shall conform to the requirements of tensile properties prescribed in Table 2.

6.2 The shape manufacturer shall furnish test reports of tensile properties determined in accordance with Sections 8, 9, and 10.

TABLE 2 Mechanical Properties

| Grade | 36 | 45 | 45W ^A | 50 | 50W ^A | 60 | 80 |
|----------------------------------|-----------------|-----------------|------------------|-----------------|------------------|-----------------|-----------------|
| Tensile strength, min, psi [MPa] | 53 000 [365] | 60 000 [415] | 65 000 [450] | 65 000 [450] | 70 000 [485] | 75 000 [520] | 90 000 [620] |
| Yield point, min, psi [MPa] | 36 000 [250] | 45 000 [310] | 45 000 [310] | 50 000 [345] | 50 000 [345] | 60 000 [415] | 80 000 [550] |
| Elongation, min, % | | | | | | | |
| in 2 in. [50 mm] | 22 | 19 | 19 | 17 | 17 | 17 | 17 |
| in 8 in. [200 mm] ^B | 15 | 14 | 14 | 12 | 12 | 12 | 12 |

^A The suffix "W" indicates steel grades having atmospheric corrosion resistance approximately two times that of carbon structural steel with copper.

^B See elongation requirement adjustments under the Tension Tests section of Specification **A6/A6M**. See specimen orientation in the Tension Tests section of Specification **A6/A6M**.

TABLE 3 Common Sizes of Electric Resistance Forge-Welded Sections

| Depth | Designation | | Area | | Weight | | Depth | | Web Thickness | | Flange Width | | Flange Thickness | |
|-------|-------------|-------|------------------|-----------------|--------|-------|-------|-----|---------------|-----|--------------|-----|------------------|-----|
| | x | lb/ft | in. ² | mm ² | lb/ft | kg/m | in. | mm | in. | mm | in. | mm | in. | mm |
| 3.50 | x | 3.57 | 1.028 | 663 | 3.57 | 5.31 | 3.50 | 89 | 0.105 | 2.7 | 3.25 | 83 | 0.105 | 2.7 |
| 3.63 | x | 5.54 | 1.599 | 1032 | 5.54 | 8.24 | 3.625 | 92 | 0.155 | 3.9 | 3.50 | 89 | 0.155 | 3.9 |
| 3.63 | x | 7.59 | 2.200 | 1419 | 7.59 | 11.30 | 3.625 | 92 | 0.155 | 3.9 | 3.50 | 89 | 0.245 | 6.2 |
| 3.63 | x | 10.28 | 2.973 | 1918 | 10.28 | 15.30 | 3.625 | 92 | 0.245 | 6.2 | 4.500 | 114 | 0.245 | 6.2 |
| 4.00 | x | 3.75 | 1.080 | 697 | 3.75 | 5.58 | 4.00 | 102 | 0.105 | 2.7 | 3.25 | 83 | 0.105 | 2.7 |
| 4.00 | x | 5.61 | 1.627 | 1050 | 5.61 | 8.35 | 4.00 | 102 | 1.105 | 2.7 | 4.00 | 102 | 0.155 | 3.9 |
| 4.00 | x | 8.62 | 2.504 | 1615 | 8.62 | 12.83 | 4.00 | 102 | 1.155 | 3.9 | 4.00 | 102 | 0.245 | 6.2 |
| 5.25 | x | 3.63 | 1.051 | 687 | 3.64 | 5.42 | 5.25 | 133 | 0.090 | 2.3 | 2.50 | 64 | 0.120 | 3.0 |
| 5.50 | x | 4.28 | 1.238 | 799 | 4.28 | 6.37 | 5.50 | 140 | 0.105 | 2.7 | 3.25 | 83 | 0.105 | 2.7 |
| 5.50 | x | 9.42 | 2.737 | 1766 | 9.42 | 14.02 | 5.50 | 140 | 0.155 | 3.9 | 4.00 | 102 | 0.245 | 6.2 |
| 6.00 | x | 4.46 | 1.290 | 832 | 4.46 | 6.64 | 6.00 | 152 | 0.105 | 2.7 | 3.25 | 83 | 0.105 | 2.7 |
| 6.00 | x | 6.80 | 1.967 | 1269 | 6.80 | 10.12 | 6.00 | 152 | 0.155 | 3.9 | 3.50 | 89 | 0.155 | 3.9 |
| 6.00 | x | 7.75 | 2.253 | 1454 | 7.75 | 11.53 | 6.00 | 152 | 0.120 | 3.0 | 4.50 | 114 | 0.175 | 4.4 |
| 6.00 | x | 9.68 | 2.814 | 1815 | 9.68 | 14.41 | 6.00 | 152 | 0.155 | 3.9 | 4.00 | 102 | 0.245 | 6.2 |
| 6.00 | x | 10.48 | 3.047 | 1966 | 10.48 | 15.60 | 6.00 | 152 | 0.175 | 4.4 | 4.25 | 108 | 0.245 | 6.2 |
| 6.00 | x | 12.41 | 3.610 | 2329 | 12.41 | 18.47 | 6.00 | 152 | 0.210 | 5.3 | 5.00 | 127 | 0.245 | 6.2 |
| 6.00 | x | 14.76 | 4.290 | 2768 | 14.76 | 21.97 | 6.00 | 152 | 0.245 | 6.2 | 6.00 | 152 | 0.245 | 6.2 |
| 6.50 | x | 4.02 | 1.181 | 762 | 4.02 | 5.98 | 6.50 | 165 | 0.090 | 2.3 | 2.50 | 64 | 0.120 | 3.0 |
| 8.00 | x | 6.38 | 1.853 | 1195 | 6.39 | 9.51 | 8.00 | 203 | 0.120 | 3.0 | 3.00 | 76 | 0.155 | 3.9 |
| 8.00 | x | 11.34 | 3.290 | 2123 | 11.34 | 16.88 | 8.00 | 203 | 0.210 | 5.3 | 3.50 | 89 | 0.245 | 6.2 |
| 8.00 | x | 21.52 | 6.276 | 4049 | 21.52 | 32.03 | 8.00 | 203 | 0.245 | 6.2 | 6.00 | 152 | 0.375 | 9.5 |
| 8.25 | x | 5.65 | 1.662 | 1072 | 5.65 | 8.41 | 8.25 | 210 | 0.090 | 2.3 | 3.00 | 76 | 0.155 | 3.9 |
| 10.00 | x | 7.59 | 2.208 | 1425 | 7.59 | 11.30 | 10.00 | 254 | 0.120 | 3.0 | 3.00 | 76 | 0.175 | 4.4 |
| 10.00 | x | 11.62 | 3.380 | 2181 | 11.62 | 17.29 | 10.00 | 254 | 0.175 | 4.4 | 3.50 | 89 | 0.245 | 6.2 |
| 10.25 | x | 7.69 | 2.238 | 1444 | 7.70 | 11.46 | 10.25 | 260 | 0.120 | 3.0 | 3.50 | 89 | 0.175 | 4.4 |
| 10.25 | x | 7.60 | 2.235 | 1442 | 7.60 | 11.31 | 10.25 | 260 | 0.100 | 2.5 | 3.50 | 89 | 0.175 | 4.4 |
| 10.25 | x | 8.28 | 2.437 | 1572 | 8.28 | 12.33 | 10.25 | 260 | 0.120 | 3.0 | 3.50 | 89 | 0.175 | 4.4 |
| 12.00 | x | 10.62 | 3.120 | 2013 | 10.62 | 15.80 | 12.00 | 305 | 0.120 | 3.0 | 3.50 | 89 | 0.245 | 6.2 |
| 12.25 | x | 9.90 | 2.911 | 1878 | 9.90 | 14.73 | 12.25 | 311 | 0.100 | 2.5 | 3.50 | 89 | 0.245 | 6.2 |
| 12.25 | x | 9.91 | 2.890 | 1865 | 9.91 | 14.75 | 12.25 | 311 | 0.120 | 3.0 | 3.50 | 89 | 0.210 | 5.3 |
| 12.25 | x | 10.71 | 3.150 | 2032 | 10.71 | 15.94 | 12.25 | 311 | 0.120 | 3.0 | 3.50 | 89 | 0.245 | 6.2 |
| 12.25 | x | 10.74 | 3.136 | 2023 | 10.74 | 15.98 | 12.25 | 311 | 0.100 | 2.5 | 4.00 | 102 | 0.245 | 6.2 |
| 12.25 | x | 11.54 | 3.371 | 2175 | 11.55 | 17.19 | 12.25 | 311 | 0.120 | 3.0 | 4.00 | 102 | 0.245 | 6.2 |
| 13.00 | x | 21.86 | 6.376 | 4114 | 21.86 | 32.53 | 13.00 | 330 | 0.245 | 6.2 | 4.50 | 114 | 0.375 | 9.5 |
| 13.00 | x | 24.41 | 7.1126 | 4597 | 24.41 | 36.33 | 13.00 | 330 | 0.245 | 6.2 | 5.50 | 140 | 0.375 | 9.5 |
| 14.00 | x | 11.43 | 3.336 | 2152 | 11.43 | 17.01 | 14.00 | 356 | 0.120 | 3.0 | 3.50 | 89 | 0.245 | 6.2 |
| 14.00 | x | 13.10 | 3.826 | 2468 | 13.10 | 19.50 | 14.00 | 356 | 0.120 | 3.0 | 4.50 | 114 | 0.245 | 6.2 |
| 16.00 | x | 14.11 | 4.150 | 2677 | 14.11 | 21.00 | 16.00 | 406 | 0.155 | 3.9 | 3.50 | 89 | 0.245 | 6.2 |

7. Permissible Variations in Dimensions

7.1 Unless otherwise agreed upon by the shape manufacturer and the purchaser, dimensional variations shall conform to Specification **A6/A6M** (12.3 and Tables 16 to Tables 24 inclusive) for shapes of similar dimensions. Thicknesses of the shape components shall be based on nominal thicknesses conforming to Specification **A6/A6M** (Table 1, plate) or Specification **A568/A568M** (Tables 4 and Tables 5) for material thickness between 0.031 to 0.230 in. inclusive or Specifi-

cation **A635/A635M** (Tables 2 and Tables 3) for material thickness between 0.230 to 1.000 in. inclusive. Nominal thickness shall be defined as the minimum thickness specified plus one half the allowable thickness tolerance as shown in the tables. The nominal weight per foot of the shape shall be calculated based on the nominal thickness and allowable variations in weight shall be equivalent to allowable variations in thickness.