



Designation: **F1862/F1862M – 13 F1862/F1862M – 17**

Standard Test Method for Resistance of Medical Face Masks to Penetration by Synthetic Blood (Horizontal Projection of Fixed Volume at a Known Velocity)¹

This standard is issued under the fixed designation F1862/F1862M; the number immediately following the designation indicates the year of original adoption or, in the case of revision, the year of last revision. A number in parentheses indicates the year of last reapproval. A superscript epsilon (ϵ) indicates an editorial change since the last revision or reapproval.

INTRODUCTION

Workers, primarily those in the ~~health-care~~ healthcare profession, involved in treating and caring for individuals injured or sick, can be exposed to biological liquids capable of transmitting disease. These diseases, which may be caused by a variety of microorganisms, can pose significant risks to life and health. This is especially true of blood-borne viruses which cause ~~Hepatitis~~ Hepatitis (~~Hepatitis~~ hepatitis B ~~Virus~~ virus (HBV) and ~~Hepatitis~~ hepatitis C ~~Virus~~ virus (HCV)) and ~~Acquired Immune Deficiency Syndrome (AIDS)~~ Human Immunodeficiency Virus (HIV) ~~acquired immune deficiency syndrome (AIDS)~~ (human immunodeficiency virus (HIV)). Because engineering controls can not eliminate all possible exposures, attention is placed on reducing the potential of direct skin and mucous membrane contact through the use of protective clothing that resists penetration (29 CFR Part 1910.1030). This test method was developed for ranking the synthetic blood penetration resistance performance of medical ace masks in a manner representing actual use as might occur when the face mask is contacted by a ~~high-velocity~~ high-velocity stream of blood from a punctured wound.

1. Scope

1.1 This test method is used to evaluate the resistance of medical face masks to penetration by the impact of a small volume (~2 mL) of a ~~high-velocity~~ high-velocity stream of synthetic blood. Medical face mask *pass/fail* determinations are based on visual detection of synthetic blood penetration.

1.2 This test method does not apply to all forms or conditions of blood-borne pathogen exposure. Users of the test method must review modes for face exposure and assess the appropriateness of this test method for their specific application.

1.3 This test method primarily addresses the performance of materials or certain material constructions used in medical face masks. This test method does not address the performance of the medical face mask's design, construction, or interfaces or other factors with the potential to affect the overall protection offered by the medical face mask and its operation (such as filtration efficiency and pressure drop). Procedures for measuring these properties are contained in Test Methods Method F2101 and MIL-M-36954C.

1.4 This test method does not address breathability of the medical face mask materials or any other properties affecting the ease of breathing through the medical face mask. This test method evaluates medical face masks as an item of protective clothing. This test method does not evaluate the performance of medical face masks for airborne exposure pathways or in the prevention of the penetration of aerosolized body fluids deposited on the medical face mask.

1.5 The values stated in SI units or inch-pound units are to be regarded separately as standard. The pressure values stated in each system are not exact equivalents. However, as the corresponding velocities are within 1 % of each other, (see **X1.4.2**), reporting of the results in either units is permitted.

1.6 *This standard does not purport to address all of the safety concerns, if any, associated with its use. It is the responsibility of the user of this standard to establish appropriate safety and health practices and determine the applicability of regulatory limitations prior to use.*

¹ This test method is under the jurisdiction of ASTM Committee **F23** on Personal Protective Clothing and Equipment and is the direct responsibility of Subcommittee **F23.40** on Biological.

Current edition approved ~~Dec. 1, 2013~~ June 1, 2017. Published ~~December 2013~~ June 2017. Originally approved in 1998. Last previous edition approved in ~~2007~~ 2013 as ~~F1862-07~~ F1862/F1862M – 13. DOI: ~~10.1520/F1862-F1862M-13~~ 10.1520/F1862-F1862M-17.

1.7 This international standard was developed in accordance with internationally recognized principles on standardization established in the Decision on Principles for the Development of International Standards, Guides and Recommendations issued by the World Trade Organization Technical Barriers to Trade (TBT) Committee.

2. Referenced Documents

2.1 ASTM Standards:²

D891 Test Methods for Specific Gravity, Apparent, of Liquid Industrial Chemicals

D1331 Test Methods for Surface and Interfacial Tension of Solutions of Paints, Solvents, Solutions of Surface-Active Agents, and Related Materials

E105 Practice for Probability Sampling of Materials

E171/E171M Practice for Conditioning and Testing Flexible Barrier Packaging

F1494 Terminology Relating to Protective Clothing

F1670/F1670M Test Method for Resistance of Materials Used in Protective Clothing to Penetration by Synthetic Blood

F1671/F1671M Test Method for Resistance of Materials Used in Protective Clothing to Penetration by Blood-Borne Pathogens Using Phi-X174 Bacteriophage Penetration as a Test System

F2101 Test Method for Evaluating the Bacterial Filtration Efficiency (BFE) of Medical Face Mask Materials, Using a Biological Aerosol of *Staphylococcus aureus*

2.2 ANSI/ASQC Standard:³

ANSI/ASQC Z1.4 Sampling Procedures and Tables for Inspection by Attributes

2.3 ISO Standard:⁴

ISO 2859-1 Sampling Plans for Inspection by Attributes

2.4 Military Standards:⁵

MIL-M-36954C Military Specification, Mask, Surgical, Disposable

2.5 OSHA Standard:⁶

29 CFR Part 1910.1030 Occupational Exposure to Blood-borne Pathogens: Final Rule, *Federal Register*, Vol 56, No 235, Dec. 6, 1991, pp. 64175–64182

3. Terminology

3.1 Definitions:

3.1.1 *aerosolized body fluids*, *n*—body fluids that have been dispersed into air as very small liquid droplets.

3.1.2 *airborne exposure pathways*, *n*—inhalation routes of exposure to the medical face mask wearer.

3.1.3 *blood-borne pathogen*, *n*—an infectious bacterium or virus, or other ~~disease-inducing~~ disease-inducing microbe carried in blood or other potentially infectious body fluids.

3.1.4 *body fluid*, *n*—any liquid produced, secreted, or excreted by the human body.

² For referenced ASTM standards, visit the ASTM website, www.astm.org, or contact ASTM Customer Service at service@astm.org. For *Annual Book of ASTM Standards* volume information, refer to the standard's Document Summary page on the ASTM website.

³ Available from American Society for Quality (ASQ), 600 N. Plankinton Ave., Milwaukee, WI 53203.

⁴ Available from American National Standards Institute (ANSI), 25 W. 43rd St., 4th Floor, New York, NY 10036.

⁵ Available from Standardization Documents Order Desk, Bldg. 4 Section D, 700 Robbins Ave., Philadelphia, PA 19111-5094, Attn: NPODS.

⁶ Available from Superintendent of Documents, U.S. Government Printing Office, Washington, DC 20402.

3.1.4.1 Discussion—

In this test method, body fluids include liquids potentially infected with blood-borne pathogens, including, but not limited to, blood, semen, vaginal secretions, cerebrospinal fluid, synovial fluid and peritoneal fluid, amniotic fluid, saliva in dental procedures, and any body fluid that is visibly contaminated with blood, and all body fluids in situations where it is difficult or impossible to differentiate between body fluids (see 29 CFR Part 1910.1030).

3.1.5 *body fluid simulant*, *n*—a liquid that is used to act as a model for human body fluids.

3.1.6 *medical face mask*, *n*—an item of protective clothing designed to protect portions of the wearer's face, including the mucous membrane areas of the wearer's nose and mouth, from contact with blood and other body fluids during medical procedures.

3.1.7 *penetration*, *n*—for *biological protective clothing*, the flow of a body fluid on a non-molecular level through closures, porous materials, seams, and pinholes, or other imperfections in protective clothing.

3.1.7.1 Discussion—

In this test method, the penetration liquid is synthetic blood, a body fluid simulant.

3.1.8 *protective clothing, n*—an item of clothing that is specifically designed and constructed for the intended purpose of isolating all or part of the body from a potential hazard; or, isolating the external environment from contamination by the wearer of the clothing.

3.1.8.1 *Discussion*—

In this test method, medical face masks are evaluated. The potential hazard of contact with blood or other body fluids is being simulated.

3.1.9 *spurt, n*—a short duration gush or volume of fluid.

3.1.9.1 *Discussion*—

In this test method, a spurt refers to the volume of fluid disbursed from the apparatus at the sample mask. It can also refer to the volume of fluid ejected from a punctured blood vessel.

3.1.10 *synthetic blood, n*—a mixture of a red dye/surfactant, thickening agent, and distilled water having a surface tension and viscosity representative of blood and some other body fluids, and the color of blood.

3.1.10.1 *Discussion*—

The synthetic blood in this test method does not simulate all of the characteristics of blood or body fluids, for example, polarity (wetting characteristics), coagulation, and content of cell matter.

~~3.1.10 *spurt, n*—a short duration gush or volume of fluid.~~

~~3.1.10.1 *Discussion*—~~

~~In this test method, a spurt refers to the volume of fluid disbursed from the apparatus at the sample mask. It can also refer to the volume of fluid ejected from a punctured blood vessel.~~

3.1.11 For definitions of other protective clothing-related terms used in this test method, refer to Terminology **F1494**.

4. Summary of Test Method

4.1 A volume of synthetic blood is disbursed at a specimen mask by a pneumatically controlled valve from a set distance to simulate the impact (splatter) of blood or other body fluid onto the specimen. The velocity and volume of fluid are set to simulate a given ~~health care~~ healthcare scenario.

4.2 Any evidence of synthetic blood penetration on the inner facing of the medical face mask (side contacting the wearer's face) constitutes a failure. Results are reported as *pass/fail*.

4.3 Specimen medical face masks are evaluated at velocities of 450, 500, and 635 cm/s. These correspond to the velocity exiting a small arterial puncture at human blood pressures of 10.7, 16.0, and 21.3 kPa (80, 120, and 160 mmHg). Test results are reported at each ~~velocity~~ velocity or corresponding pressure, and the medical face mask is rated at the highest corresponding blood pressure for which medical face mask specimens demonstrate an acceptable quality limit of 4.0.

5. Significance and Use

5.1 This test method offers a procedure for evaluating medical face mask resistance to synthetic blood penetration that is useful in establishing claims for penetration resistance performance of medical face masks and ranking their performance. However, this test method does not define acceptable levels of penetration resistance because this determination must be made by each responsible user organization based on its own specific application and conditions. Therefore, when using this test method to make claims for the performance of medical face masks, the specific conditions under which testing is conducted must be described.

5.2 Medical face masks are intended to resist liquid penetration from the splatter or splashing of blood, body fluids, and other potentially infectious materials. Many factors affect the wetting and penetration characteristics of body fluids, such as surface tension, viscosity, and polarity of the fluid, as well as the structure and relative hydrophilicity or hydrophobicity of the materials and the design of the mask itself. The surface tension range for blood and body fluids (excluding saliva) is approximately 0.042 to 0.060 N/m.⁷ To help simulate the wetting characteristics of blood and body fluids, the surface tension of the synthetic blood is adjusted to approximate the lower end of this surface tension range. The resulting surface tension of the synthetic blood is 0.042 ± 0.002 N/m.

⁷ Lentner, C., ed., *Geigy Scientific Tables*, Vol 1 — Units of Measurement, Body Fluids, Composition of Blood, Hematology, Somatometric Data, Medical Education Div., Ciba-Geigy Corp., West Caldwell, NJ, 1984.

5.3 The synthetic blood mixture is prepared with a red dye to aid in visual detection and a thickening agent to simulate the flow characteristics of blood. The synthetic blood will not always duplicate the polarity, and thus the wetting behavior and subsequent penetration, of real blood and other body fluids through protective clothing materials.

5.4 During a medical procedure, a blood vessel is occasionally punctured resulting in a high velocity stream of blood impacting a protective medical face mask. The impact velocity depends on several factors, the most important being the blood pressure of the patient. Other factors include the size of the ~~puncture~~, puncture and distance from the puncture. Because the pressure, and thus velocity drops quickly with large punctures, large punctures were not used to model the range of blood splatter velocities considered in this test. Furthermore, this test method is based on the assumption that the medical face mask will be in close proximity (within 300 mm or 12 in.) to the puncture area. The use of this test method is, therefore, based on selecting an appropriate blood pressure, finding the corresponding stream or impact velocity, and determining the valve time to create that stream velocity as shown in **Appendix X1**.

5.4.1 The mean human blood pressure generally varies over a range of about 10.7 to 16.0 kPa (80 to 120 mmHg).⁸ In this test method, medical face masks are tested at stream velocities corresponding to 10.7 kPa, 16.0 kPa, and 21.3 kPa (80 mmHg, 120 ~~mm Hg~~, mmHg, and 160 ~~mm Hg~~), mmHg).

5.5 This test method permits the use of other non-standard test pressures, stream velocities, fluid volumes, and specimen orientations for evaluating medical face mask penetration resistance consistent with specific applications.

5.6 This test method differs from Test Method ~~F1670~~F1670/~~F1670M~~ by dispensing a stream of 2 mL of synthetic blood against the target area of a complete medical mask specimen, whereas Test Method ~~F1670~~F1670/~~F1670M~~ involves the continuous contact of a specimen of protective clothing with synthetic blood over the period of an hour. One minute of the exposure in Test Method ~~F1670~~F1670/~~F1670M~~ is at hydrostatic pressure of 13.8 kPa [2.0 psig]. Test Method ~~F1670~~F1670/~~F1670M~~ is used for preliminary evaluation of protective clothing penetration resistance to synthetic blood in conjunction with Test Method ~~F1671~~F1671/~~F1671M~~ that uses a microbiological challenge. Both procedures are intended for assessment of protective clothing which has the potential to contact blood or other body fluids for extended periods of time, and under pressure.

5.7 Users of this test method must realize that certain tradeoffs exist between improved resistance of medical face masks to penetration by synthetic blood and in pressure drop across mask materials as an indicator of medical face mask breathability. In general, increasing synthetic blood penetration resistance for medical face masks results in increasing pressure drop or reduced breathability for medical face masks of the same design and fit of the individual wearer.

5.8 This test method evaluates medical face masks as an item of protective clothing and does not evaluate medical face masks as respirators. If respiratory protection for the wearer is needed, a NIOSH-certified respirator must be used. This test method is useful to evaluate the resistance of a respirator to penetration by synthetic blood, if warranted.

5.9 This test method involves the preconditioning of specimen medical face masks in a relatively high humidity environment ($85 \pm 5\%$ relative humidity at $21 \pm 5^\circ\text{C}$ [$70 \pm 10^\circ\text{F}$])¹⁰ to simulate the conditions of use when the wearer creates high humidity conditions by breathing through the mask. This preconditioning does not account for saturation of the interior medical face mask layer. However, additional pretreatment techniques in conjunction with this test method as described in **5.10** are permitted. Professional ~~health care~~ healthcare providers recommend that medical face masks be replaced when saturation occurs from breathing or from contact with other liquids.

5.10 Testing prior to degradation by physical, chemical, and thermal stresses which could negatively impact the performance of the protective barrier, could lead to a false sense of security. Consider tests which assess the impact of storage conditions and shelf life for disposable products, and the effects of laundering and sterilization for reusable products. The integrity of the protective clothing is occasionally compromised during use by such effects as flexing and abrasion.⁹ It is also possible that pre-wetting by contaminants such as alcohol and perspiration also compromises the integrity of the protective clothing. If these conditions are of concern, evaluate the performance of protective clothing for synthetic blood penetration following an appropriate pretreatment technique representative of the expected conditions of use.

5.11 While this test method involves a qualitative determination of the medical face mask resistance to penetration by synthetic blood under specific test conditions, it is possible to use this test method as a material quality control or assurance procedure.

5.12 If this procedure is used for quality control, perform proper statistical design and analysis of larger data sets when more than the required specimens are tested. This type of analysis includes, but is not limited to, the number of individual specimens tested, the average percent passing or failing, or both, with a standard deviation. Data reported in this way help to establish confidence limits concerning product performance. Examples of acceptable sampling plans are found in references such as ANSI/ASQC Z1.4 and ISO 2859-1.

⁸ Barach, P. G., Cullen, ~~B. F.~~ B. F., and Stoelting, R. K., *Handbook on Clinical Anesthesia*, Appendix A, J. B. Lippincott Co., Philadelphia, 1994.

⁹ Telford, G. L. and Quebbeman, E. J., "Assessing the Risk of Blood Exposure in the Operating Room," *American Journal of Infection Control*, Vol 21, No. 6, December 1993, pp. ~~354-356~~ 351-356.

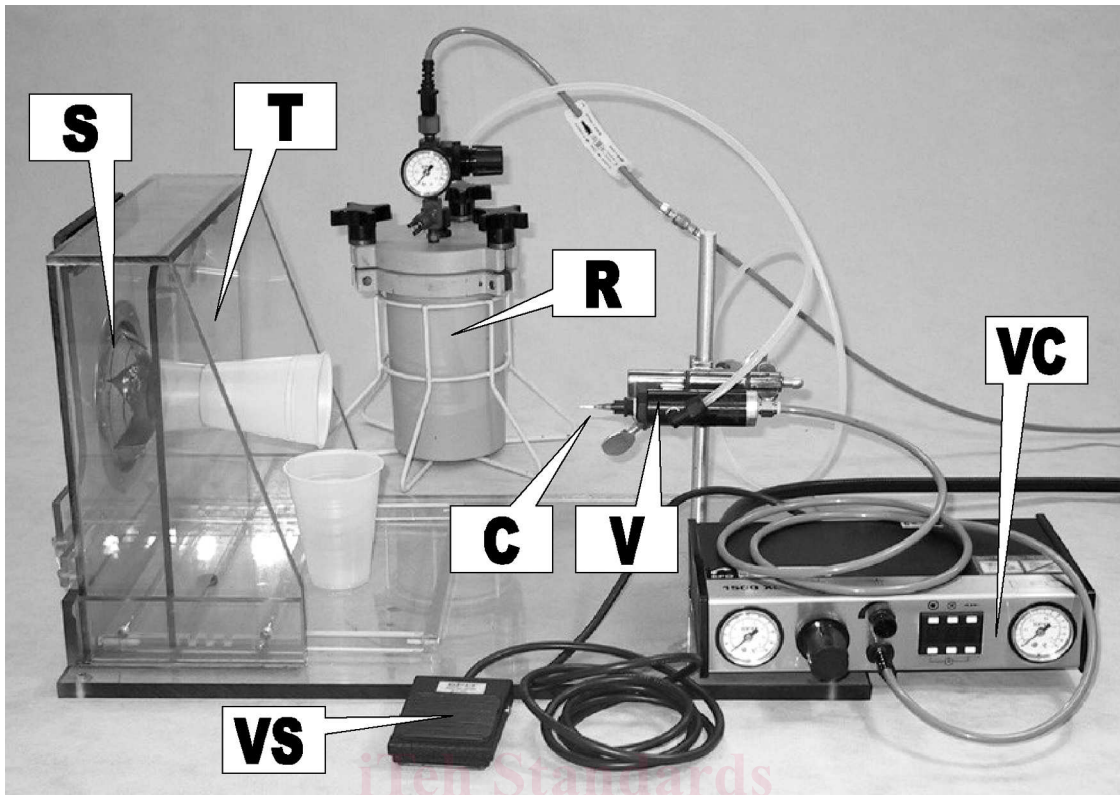

NOTE 1—

S = Sample Holder
 R = Pressurized Fluid Reservoir
 V = Valve
 VS = Valve Switch
 S = Specimen Holder
 R = Pressurized Fluid Reservoir
 V = Valve
 VS = Valve Switch

T = Targeting Plate with Collection Cups
 C = Cannula
 VC = Valve Timing Controller
 T = Targeting Plate with Collection Cups
 C = Cannula
 VC = Valve Timing Controller

ASTM F1862/F1862M-17

<https://standards.iteh.ai/catalog/standards/sist/51420100-4200-4770-9000-000000000000/astm-f1862-f1862m-17> FIG. 1 (a) Test Apparatus - aecb-54a267071e79/astm-f1862-f1862m-17

5.13 In the case of a dispute arising from differences in reported results when using this test method for acceptance testing of commercial shipments, conduct comparative tests between the purchaser and supplier to determine if there is a statistical bias between their laboratories. Competent statistical assistance is recommended for investigation of bias. As a minimum, take a group of test specimens which are as homogeneous as possible and which are from a lot of the product of the type in question. Randomly assign test specimens in equal numbers to each laboratory for testing. Compare the average results from the two laboratories using a non-parametric test for unpaired data and an acceptable probability level chosen by the two parties before testing is begun. If a bias is found, either its cause must be found and corrected or the purchaser and the supplier must agree to interpret future test results with consideration to the known bias.

6. Apparatus

6.1 *Test Apparatus*, to dispense a specified volume of synthetic blood through a small diameter cannula over a controlled amount of time at a specimen mask a set distance away. The test apparatus consists of a specimen holding fixture, a targeting plate, a pressurized fluid reservoir, a pneumatically actuated valve with interchangeable cannula, and a valve controller. A permitted optional design for the test apparatus includes a base for more convenient mounting of the components and a hood or other components to contain or control the splash. A photograph of a typical sample test apparatus is provided in Fig. 1(a). Fig. 1(b) provides an example of an alternative apparatus with the addition of a funnel to collect excess liquid so that the level in the reservoir can be estimated to help prevent running out of synthetic blood in the middle of a test lot. Fig. 1(c) and Fig. 1(d) show the incorporation of X-Y-Z axis slides for easy, smooth fine-tuning of cannula position that also helps keep pneumatic valve steady to reduce the risk of accidentally bumping it out of adjustment. Other specifications for the specimen holding fixture include as follows:

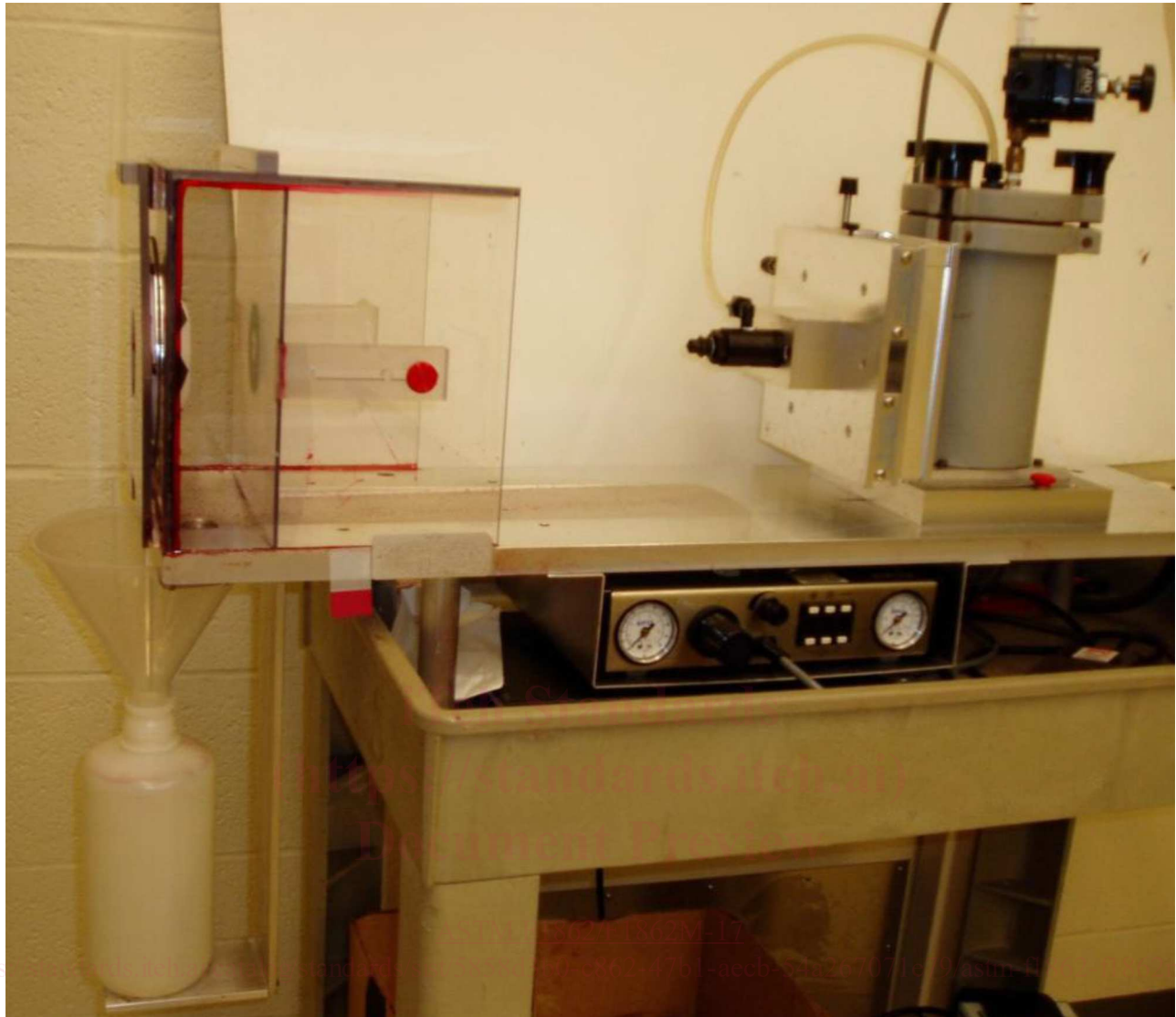

FIG. 1 (b) Test Apparatus (continued)

6.1.1 *Specimen Holding Fixture*, to support the specimen mask during the test. The design and construction of the specimen holding fixture has a significant impact on the outcome of the test. The specimen holder and supporting frame must be sufficiently stiff and rigid that the energy of the impact of the spurt is absorbed solely by the specimen mask. The specimen holder and frame must not deform, flex, or bend during a test. If necessary, alter the fixture design details from that described below, in order to provide appropriate sample specimen presentation while maintaining the intent of the method described herein.

6.1.1.1 The standard backing form for the specimen holder is a solid section of a 12.7 cm [5 in.] 12.7 cm [5 in.] diameter sphere. Use a form made of a material with a Shore A hardness of at least 40. (See Note 1.) The form has a 5.7 cm [2.25 in.] 5.7 cm [2.25 in.] diameter viewing hole through its center as shown in Fig. 2 and Fig. 3.

NOTE 1—A backing form can be made from liquid polyester resin (found at home improvement centers or auto parts stores), a 5-in. ball candle mold (candle supply companies such as genwax.com), and a 2-in. PVC tubing union (2.25 in., 5.7 cm outside diameter, found at home improvement centers). Mark a ring around the outside of the union $1\frac{3}{8}$ in. [3.0 cm] from one end. This will indicate the proper depth to fill the form to fit the apparatus described in this method. The depth can be adjusted to accommodate variations in the design of the specimen mask holder. The key element is to maintain the diameter of the form at the plane of the cuff at 4.125 in. [10.5 cm]. Using plumbers plumber's putty on the end of the union opposite the depth mark, seal the union to the inside of one half of the ball mold. Set the mold in the mold stand. Rest a level on the union to ensure the hold is horizontal in all directions. Mix about 12 oz of resin and 25 drops of hardener in a well-ventilated area. Carefully pour the resin into the mold outside of the union, making an annular form. Fill the mold up to the line on the union, taking into account the meniscus of the fluid. Once hardened, remove the form from the mold and the union from the mold. The use of a short piece of 2-in. PVC tubing is suitable to carefully knock the union out of the mold. Sand the base of the mold such that the surface is flush. Drill and tap mounting holes into the mold.

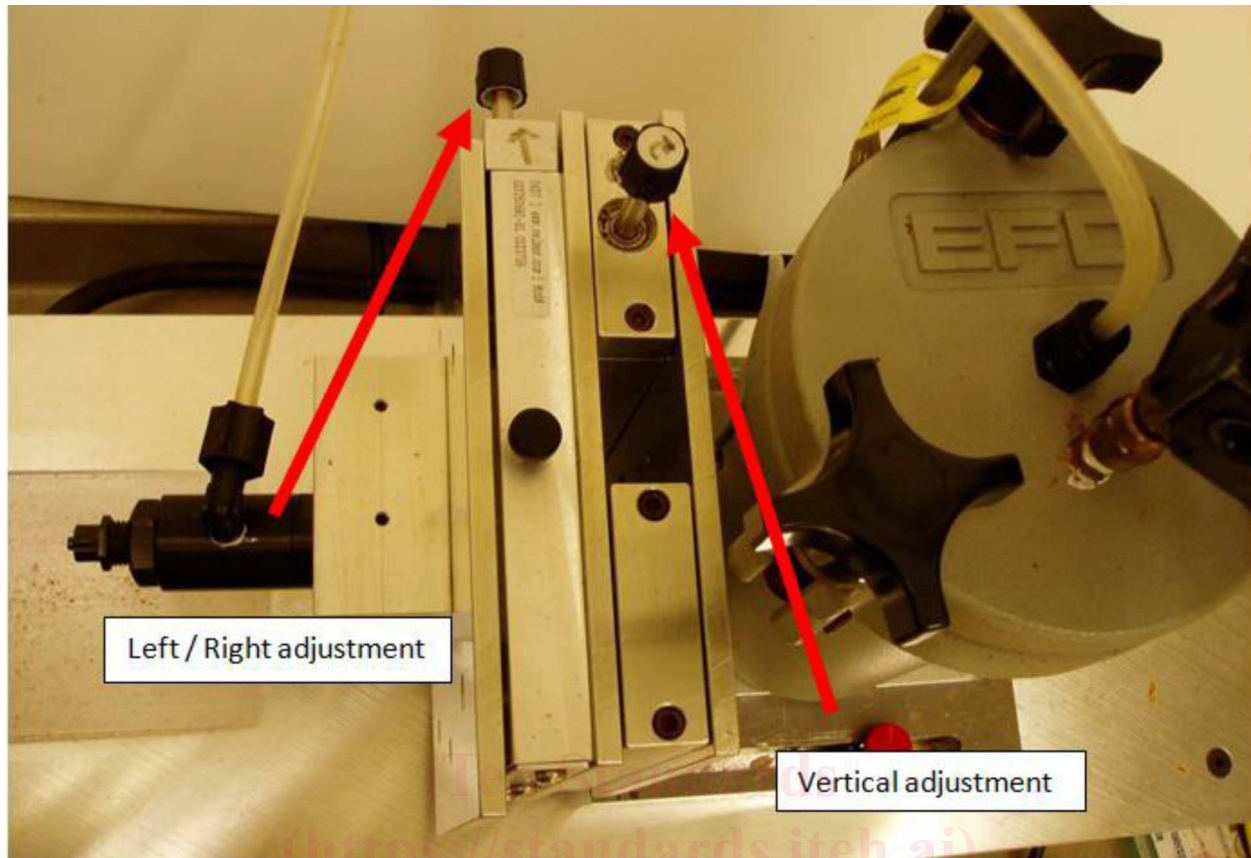

FIG. 1 (c) Left/Right and Vertical Adjustment (continued)

6.1.1.2 The backing form is mounted to a plate which is hinged¹⁰ to the specimen holder frame so there is a 0.6-cm [0.25-in.] gap between the plate and the frame, as in Fig. 2. The frame contains an 11.75-cm [4 5/8-in.] hole to receive the backing form.

6.1.1.3 A rubber cuff which partially covers the hole is secured to the frame. The cuff draws the specimen mask across the backing form. Use a cuff made from 0.08-cm [1/32-in.] buna-N gasket material with a Shore A hardness of 70.¹¹ The dimensions of the six-point star-shaped opening in the cuff are detailed in Fig. 4.

6.1.2 Targeting Plate, to block the high-velocity leading edge of the fluid stream and to provide a means of ensuring the fluid stream hits the target area of the specimen mask. The plate contains a 3/16-in. diameter hole. Ensure that the thickness of the targeting plate at the hole does not exceed 3/16 in. beyond the hole and is made of clear plastic. The plate is configured upright and placed approximately 1/2 in. in front of the specimen mask, between the mask and the ~~annula~~cannula, such that the stream impacts the center of hole in the mask supporting form.

6.1.2.1 A suitable method for containing the splatter of fluid hitting the targeting plate uses a disposable plastic cup with a hole larger than 3/16 in. diameter cut out of the bottom.¹² The cup is mounted horizontally with the opening facing the nozzle by any convenient method. The run-off is suitably collected by a second cup placed below the lip of targeting cup, as shown in Fig. 1.

6.1.3 ~~Pneumatically-Actuated Valve~~Pneumatically Actuated Valve,¹³ shall be mounted on a stiff support, such as a ring stand. The valve support shall not flex when the valve is actuated. The valve shall be positioned so that the exit of the ~~annula~~cannula is 30.5 cm [12.0 in.] from the point of impact on the specimen mask.

6.1.3.1 Valve Maintenance—Periodically disassemble and clean the pneumatically actuated valve with isopropanol to prevent interference with the valve mechanism or plugging of the ~~annula~~cannula, which can lead to inconsistent valve performance.

6.1.4 Valve Controller,¹⁴ to set the duration of the fluid spurt. Use a valve controller with a resolution and accuracy of at least 0.01 ± 0.005 seconds.

¹⁰ A continuous plastic hinge provides a little more give than a rigid piano hinge. Reference McMaster Carr 11195A41. McMaster-Carr Supply Company, Atlanta, Georgia.

¹¹ Reference McMaster-Carr item 8635K161—12-8635K161 - 12 in. by 12 in. sheets of 70A hardness 1/32 in. thick Buna-N gasket material. McMaster-Carr Supply Company, Atlanta, Georgia.

¹² Reference McMaster-Carr 3427A57—3427A57 - 3/16-in. Arch Punch for making the targeting plate holes in soft materials. McMaster-Carr Supply Company, Atlanta, Georgia.

¹³ Reference EFD Model 725D pneumatic fluid dispensing valve or equivalent. EFD, 977 Waterman Ave. East Providence, RI 0291402914.

¹⁴ Reference EFD 1500D controller or equivalent. A remote hand or foot actuated switch can also be used with the 1500D controller. EFD, 977 Waterman Ave. East Providence, RI 0291402914.

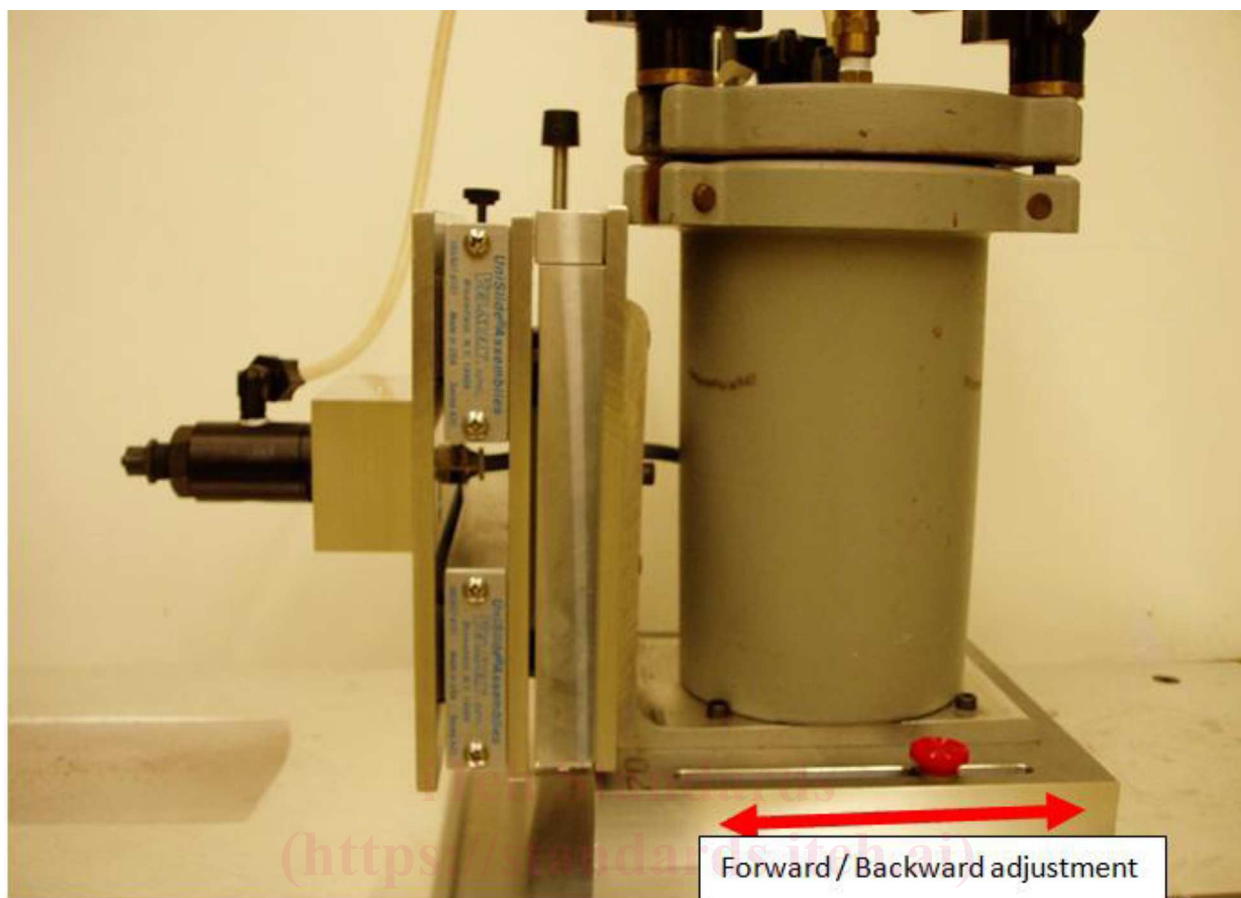

FIG. 1 (d) Forward and Backward Adjustment (continued)

6.1.5 Cannula,¹⁵ which which attaches to the exit of the valve. The standard for this method is a 1.27-cm [0.5-in.] long 1.27-cm [0.5-in.] long, 18 gauge stainless steel cannula with an internal diameter of 0.084 cm [0.033 in.].

6.1.5.1 Deviations from the standard cannula must be noted in the test report.

6.1.6 Pressure-Regulated Fluid Reservoir, to contain the synthetic blood for delivery to the nozzle.¹⁶

6.2 Air Pressure Source, capable of providing air at a gauge pressure recommended by manufacturer of valve controller.

6.3 Balance, calibrated to measure weight with a precision of at least 0.01 grams-g.¹⁷

6.4 Beaker or Cup, to collect the synthetic blood discharged from the nozzle and cannula.

6.5 Temperature/Humidity Recorder, to monitor ambient conditions during testing.

6.6 Controlled Temperature and Humidity Chamber or Space, capable of achieving and maintaining specified temperature and humidity conditions.

7. Reagents

7.1 Synthetic Blood¹⁸—If synthetic blood is not purchased, prepare using the following ingredients:

7.1.1 High Performance Liquid Chromatography (HPLC), quality distilled water (± 0.0975 L, pH 7.0 ± 0.5).

7.1.2 Acrysol G111 Thickening agent, 25.050.0 g.

7.1.3 Red dye, containing colorant and surfactant, 10.0 grams-g.

7.1.4 To reduce biological contamination, boil the distilled water for 5 min and allow to cool to room temperature before mixing. Measure amount of distilled water at $20 \pm 1^\circ\text{C}$ after boiling.

7.1.5 Add the thickening agent to the distilled water and mix 45 min at room temperature on a magnetic stirring plate.

¹⁵ Reference EFD Part Number 5118-B. EFD, 977 Waterman Ave. East Providence, RI 02914.

¹⁶ Reference EFD parts: 615DTH fluid reservoir; 615DRL fluid reservoir cover and liner; 61520 reservoir stand; 2000f755 air filter and regulator; 1116 air tree EFD, 977 Waterman Ave. East Providence, RI 02914.

¹⁷ Weighing the fluid output is faster and more accurate than measuring the fluid volume.

¹⁸ Prepared synthetic blood meeting this specification, and small quantities of Direct Red 081, CI No. 28160 (Morfast Red 8BL) and Acrysol G110 are available from Johnson, Moen & Co., 2505 Northridge Lane NE, Rochester, MN 55906-JM & Co., 507-208-6390. Acrysol G111 is available from Dow Chemical Company.

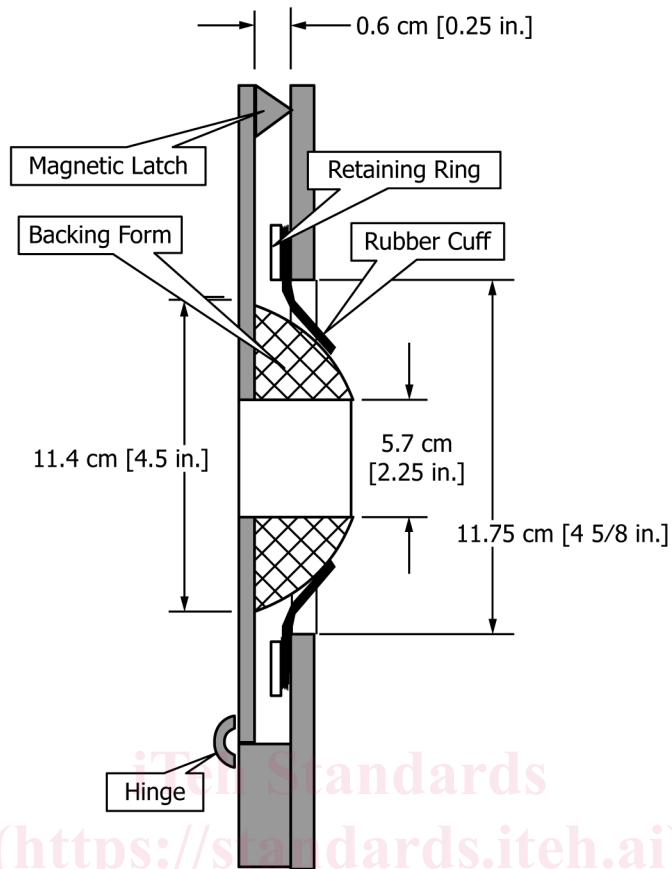

FIG. 2 Schematic of Specimen Holding Fixture



FIG. 3 Specimen Holding Fixture

7.1.6 Add the red dye and mix 1 h or more.

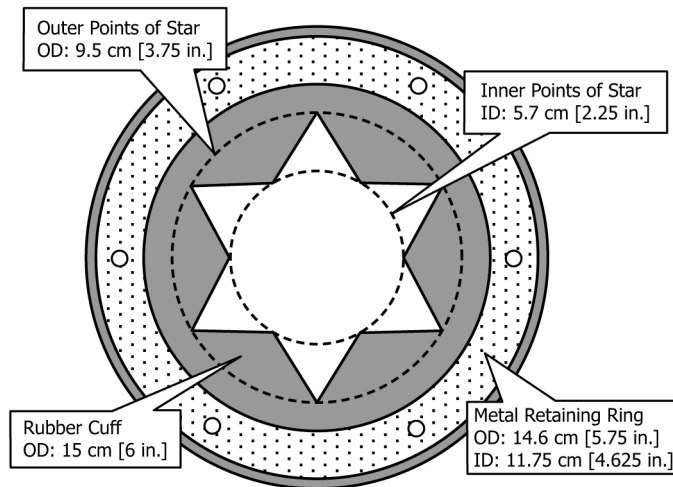

FIG. 4 Schematic of Specimen Retaining Cuff



FIG. 5 Disposable Cup Targeting Plate

NOTE 2—The red dye will stain skin, clothes, and work surfaces.

7.1.7 ~~Determine~~ Measure the corrected surface tension of the solution using Test Method Methods D1331. The expected value of the corrected surface tension is 0.042 ± 0.002 N/m. Do not use synthetic blood solutions unless within the specified range of D1331, DuNouy ring (Method A). The surface tension measurement declines over time in an undisturbed dish. After filling the sample container using the mixing method in 7.1.10 surface tension, let the solution sit for 20 min before beginning the surface tension measurement procedure. The surface tension, measured by ring after 20 min, shall be 40 ± 5 dyn/cm.