



Designation: ~~D1478 – 11~~ **D1478 – 11 (Reapproved 2017)<sup>ε1</sup>**

## Standard Test Method for Low-Temperature Torque of Ball Bearing Grease<sup>1</sup>

This standard is issued under the fixed designation D1478; the number immediately following the designation indicates the year of original adoption or, in the case of revision, the year of last revision. A number in parentheses indicates the year of last reappraisal. A superscript epsilon ( $\epsilon$ ) indicates an editorial change since the last revision or reappraisal.

*This standard has been approved for use by agencies of the U.S. Department of Defense.*

---

<sup>ε1</sup> NOTE—Reference to withdrawn ADJD3336 was removed editorially in June 2017.

---

### 1. Scope

1.1 This test method covers the determination of the extent to which a grease retards the rotation of a slow-speed ball bearing by measuring starting and running torques at low temperatures (~~below  $-20^{\circ}\text{C}$  ( $0^{\circ}\text{F}$ )~~); (below  $-20^{\circ}\text{C}$  ( $0^{\circ}\text{F}$ )).

1.1.1 Torque measurements are limited by the capacity of the torque-measuring equipment.

NOTE 1—When initially developed, the original dynamometer scale limited the torque capacity to approximately ~~30 000 g·cm~~; 30 000 g·cm; the original dynamometer scale is obsolete, however. The suggested replacement scale has not been evaluated; it could extend the limit to approximately ~~75 000 g·cm~~; 75 000 g·cm.

1.2 The values stated in SI units are to be regarded as standard. ~~The values given in parentheses are for information only. The exception is torque values that are given in cgs-metric units, which are universally used in grease specifications.~~

1.2.1 *Exceptions*—~~The values given in parentheses are for information only. The exception is torque values that are given in cgs-metric units, which are universally used in grease specifications.~~

1.3 *This standard does not purport to address all of the safety concerns, if any, associated with its use. It is the responsibility of the user of this standard to establish appropriate safety and health practices and determine the applicability of regulatory limitations prior to use.* For specific hazard and warning statements, see [6.1.1](#), [7.2](#), [7.4](#), [8.7](#), and [8.11](#).

1.4 *This international standard was developed in accordance with internationally recognized principles on standardization established in the Decision on Principles for the Development of International Standards, Guides and Recommendations issued by the World Trade Organization Technical Barriers to Trade (TBT) Committee.*

### 2. Referenced Documents

2.1 *ASTM Standards:*<sup>2</sup>

[D4693 Test Method for Low-Temperature Torque of Grease-Lubricated Wheel Bearings](#)<sup>1</sup>

2.2 *ANSI/AFBMA Standard:*

[Standard 20-1987 Radial Bearings of Ball, Cylindrical, Roller, and Spherical-Roller Type—Metric Designs \(AFBMA Code 20BCO2JO\)](#)<sup>3</sup>

2.3 *ASTM Adjuncts:*

~~Standard ball bearings (set of 5 ball bearings)~~<sup>4</sup>

### 3. Terminology

3.1 *Definitions of Terms Specific to This Standard:*

3.1.1 *low-temperature torque, n*—the torque in g·cm required to restrain the outer ring of a No. 6204 size open ball bearing lubricated with the test grease while the inner ring is rotated at  ~~$\pm 1 \text{ r/min} \pm 0.050.05 \text{ r/min}$~~  at the test temperature.

3.1.2 *running torque, n*—the  ~~$\pm 5$~~  15 s average value of the torque after rotation for a specified period of time (~~60 min~~); (60 min).

3.1.3 *starting torque, n*—the maximum torque measured at the start of rotation.

<sup>1</sup> This test method is under the jurisdiction of ASTM Committee D02 on Petroleum Products, Liquid Fuels, and Lubricants and is the direct responsibility of Subcommittee D02.G0.05 on Functional Tests - Temperature.

Current edition approved May 1, 2011. Published ~~May 2011~~ June 2017. Originally approved in 1957. Last previous edition approved in ~~2007~~ 2011 as ~~D1478D1478 – 11, –07~~. DOI: ~~10.1520/D1478-11~~ 10.1520/D1478-11R17E01.

<sup>2</sup> For referenced ASTM standards, visit the ASTM website, [www.astm.org](http://www.astm.org), or contact ASTM Customer Service at [service@astm.org](mailto:service@astm.org). For *Annual Book of ASTM Standards* volume information, refer to the standard's Document Summary page on the ASTM website.

<sup>3</sup> Available from AFBMA (Anti-Friction Bearing Manufacturers' Association), 1101 Connecticut Avenue, N.W., Suite 700, Washington, DC 20036-4303.

\*A Summary of Changes section appears at the end of this standard

#### 4. Summary of Test Method

4.1 A No. 6204 open ball bearing is packed completely full of the test grease and cleaned off flush with the sides. The bearing remains stationary while ambient temperature is lowered to the test temperature and held there for ~~2 h~~ 2 h. At the end of this time, the inner ring of the ball bearing is rotated at  ~~$\pm 1 \text{ r/min} \pm 0.050 \text{ r/min}$~~   $\pm 1 \text{ r/min}$  while the restraining force on the outer ring is measured.

4.2 Torque is determined by multiplying the restraining force by the radius of the bearing housing. Both starting torque and torque after ~~60 min~~ 60 min of rotation (running torque) are determined.

#### 5. Significance and Use

5.1 This test method was developed using greases having very low torque characteristics at  ~~$-54^\circ\text{C}$  ( $-65^\circ\text{F}$ )~~ at  $-54^\circ\text{C}$  ( $-65^\circ\text{F}$ ). Specifications for greases of this type commonly require testing at this temperature. Specifications for greases of other types can require testing at temperatures ~~from  $-75$  to  $-20^\circ\text{C}$  ( $-100$  to  $0^\circ\text{F}$ )~~ from  $-75^\circ\text{C}$  to  $-20^\circ\text{C}$  ( $-100^\circ\text{F}$  to  $0^\circ\text{F}$ ).

5.2 This test method has proved helpful in the selection of greases for low-powered mechanisms, such as instrument bearings used in aerospace applications. The suitability of this test method for other applications requiring different greases, speeds, and temperatures should be determined on an individual basis.

5.3 Test Method **D4693** may be better suited for applications using larger bearings or greater loads. However, greases having such characteristics that permit torque evaluations by either this test method or Test Method **D4693** will not give the same values in the two test methods (even when converted to the same torque units) because the apparatus and test bearings are different.

#### 6. Apparatus

6.1 **Fig. 1** shows a suitable torque test apparatus assembly.

It consists of the components described in **6.1.1** – **6.1.5**.

6.1.1 *Low-Temperature Box*—Any well-insulated box of at least  ~~$0.03\text{ m}^3$  ( $1\text{ ft}^3$ )~~  $0.03\text{ m}^3$  ( $1\text{ ft}^3$ ) interior volume, in which the air temperature can be controlled and maintained within  ~~$0.5^\circ\text{C}$  ( $1^\circ\text{F}$ )~~  $0.5^\circ\text{C}$  ( $1^\circ\text{F}$ ) of the test temperature. (**Warning**—Direct impact on the test bearing by an air stream colder than the test temperature must be avoided to preclude erroneous results. Baffles should be used where necessary to prevent such direct impact. The drive mechanism can be mounted externally as shown in **Fig. 2**, or the entire drive mechanism can be inserted directly into the box. When the drive is mounted externally, the temperature measured at a point on the surface of the test shaft between the test bearing and wall of the box shall be not more than  ~~$0.5^\circ\text{C}$  ( $1^\circ\text{F}$ )~~  $0.5^\circ\text{C}$  ( $1^\circ\text{F}$ ) above the test temperature.)

6.1.2 *Drive Assembly*, as shown in **Fig. 2**, including drive motor, gear reductor, and test shaft. The test shaft shall receive the test bearing against a shoulder having a diameter smaller than the inner race shoulder of the bearing. Use a spacer washer of the same diameter and at least  ~~$1.6\text{ mm}$  ( $1/16\text{ in.}$ )~~  $1.6\text{ mm}$  ( $1/16\text{ in.}$ ) thick, along with a test bearing lock nut, to clamp the inner ring of the test bearing to the  ~~$\pm 1 \text{ r/min}$~~   $\pm 1 \text{ r/min}$  shaft.

6.1.3 *Housing (Cage)*—Bearing housing, load disk, load ring, clamp rod, and associated parts made in accordance with **Fig. 3**. Adjust the mass of Part 2A (load disk) to be  ~~$454 \pm 3\text{ g}$  ( $1\text{ lb.}$ )~~  $454\text{ g} \pm 3\text{ g}$  ( $1\text{ lb.}$ ). Alternatively, if Part 2B (load ring) is used, adjust the mass of Part 2B to be  ~~$454 \pm 3\text{ g}$  ( $1\text{ lb.}$ )~~  $454\text{ g} \pm 3\text{ g}$  ( $1\text{ lb.}$ ).

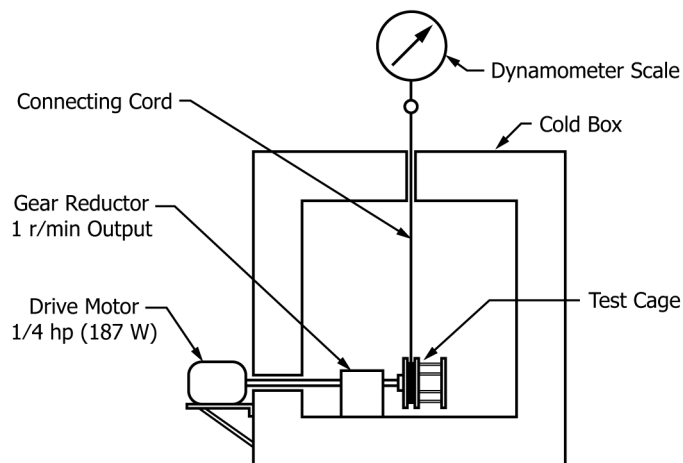

FIG. 1 Torque Test Apparatus Assembly

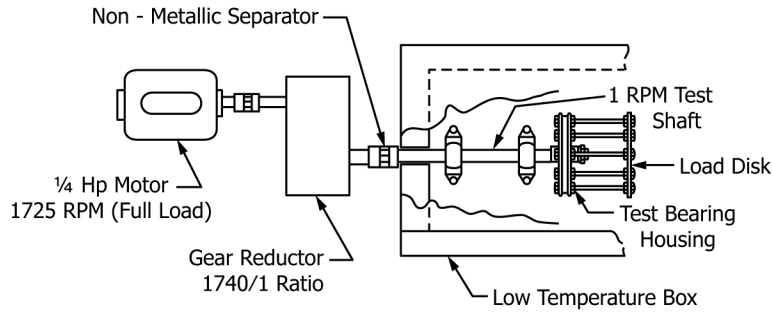

FIG. 2 Drive (Top View)

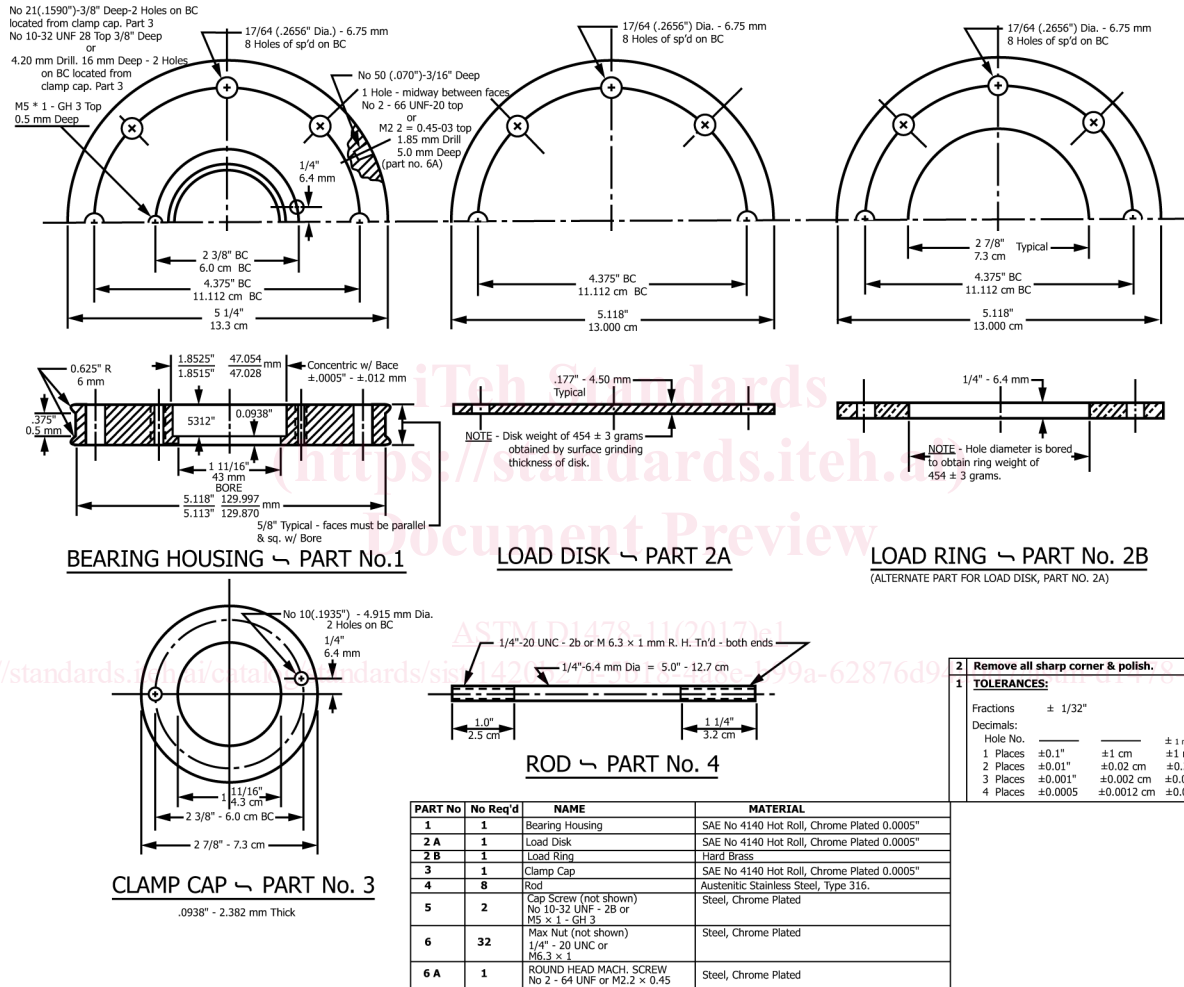

FIG. 3 Cage Parts

6.1.4 *Torque-Measuring Equipment*—A calibrated dynamometer scale<sup>4</sup> having a range of approximately 0 to 10 kg, 0 to 100 N, or 0 to 25 lb, 0 kg to 10 kg, 0 N to 100 N, or 0 lb to 25 lb, with a large face diameter (approximately 200 mm (8 in.), 200 mm (8 in.), or larger) and a suitable connecting cord of sufficient length (either braided metallic cable fitted with a ring or loop on each end or a 15-kg (35-lb) 15 kg (35 lb) test string saturated with silicone oil).

<sup>4</sup>The ball bearing has been standardized by Subcommittee D02.G0. Available from ASTM International Headquarters. Order Adjunct No. ADJD3336. Original adjunct produced in 1984.

<sup>4</sup>The sole source of supply of the Dynamometer Scale, QDS-25 previously known to the committee was R. Chatillon & Sons Inc., 83-28 Kew Gardens Rd., Kew Gardens, NY 11415. However, it is understood that over time, this Dynamometer Scale became obsolete, and it is no longer commercially available. If you are aware of potential alternative suppliers, please provide this information to ASTM International Headquarters. Your comments will receive careful consideration at a meeting of the responsible technical committee,<sup>1</sup> which you may attend.

NOTE 2—Substitution of other suitable torque-measuring equipment, such as a strain-gage load cell, is permitted.

6.1.5 *Spindle and Grease Cup*, as shown in Fig. 4 and Fig. 5, respectively.

**7. Materials**

7.1 *Test Bearing*—No. 6204 size open ball bearing (Standard 20-1987, AFBMA Code 20BCO2JO) containing eight 7.9 mm 7.9 mm (5/16 in. in.) balls, separated by a two-piece, pressed steel cage, and manufactured to ABEC-3 (Annular Bearing Engineering Committee) tolerances with the standard radial clearance of 0.021 to 0.028 mm (0.0008 to 0.0011 in.).<sup>5</sup>

7.2 *Mineral Spirits, Reagent Grade.* (**Warning**—Combustible. Health Hazard.)

7.3 *Purity of Reagents*—Reagent grade chemicals shall be used in all tests. Unless otherwise indicated, it is intended that all reagents shall conform to the specifications of the committee on Analytical Reagents of the American Chemical Society, where such specifications are available.<sup>6</sup>

7.4 *n-Heptane*, reagent grade minimum purity. (**Warning**—Flammable. Health Hazard.)

**8. Procedure**

8.1 Wash the selected test bearing thoroughly in mineral spirits and rinse it in a beaker of *n*-heptane. Dry the bearing for approximately 20 min 20 min in a warm oven (not over 100°C (212°F) 100 °C (212 °F)). Permit the bearing to cool to room temperature before proceeding.

8.2 Lubricate the bearing with five drops of oil having a viscosity of 2828 cSt to 32 cSt at 100°C (135 to 150 SUS at 210°F) 32 cSt at 100 °C (135 SUS to 150 SUS at 210 °F). The bearing shall then show no roughness or catching when rotated between the fingers while applying light pressure axially and then radially. Use the dynamometer to determine the running torque at room temperature; note the average and maximum running torque peaks. The average shall not exceed 20 g-cm (2.0 mN-m), 20 g-cm (2.0 mN-m), and no peak shall exceed 25 g-cm 25 g-cm (2.5 mN-m). If torque values fall below these limits, the bearing is suitable for the grease torque test. If torque values exceed these limits, the bearing should be recleaned and retested or discarded.

<sup>5</sup> Supporting data (copies of correspondence and test data regarding the selection of the test bearing) have been filed at ASTM International Headquarters and may be obtained by requesting Research Report RR:D02-1272. Contact ASTM Customer Service at service@astm.org.

<sup>6</sup> *Reagent Chemicals, American Chemical Society Specifications*, American Chemical Society, Washington, DC. For Suggestions on the testing of reagents not listed by the American Chemical Society, see *Annual Standards for Laboratory Chemicals*, BDH Ltd., Poole, Dorset, U.K., and the *United States Pharmacopeia and National Formulary*, U.S. Pharmacopeial Convention, Inc. (USPC), Rockville, MD.

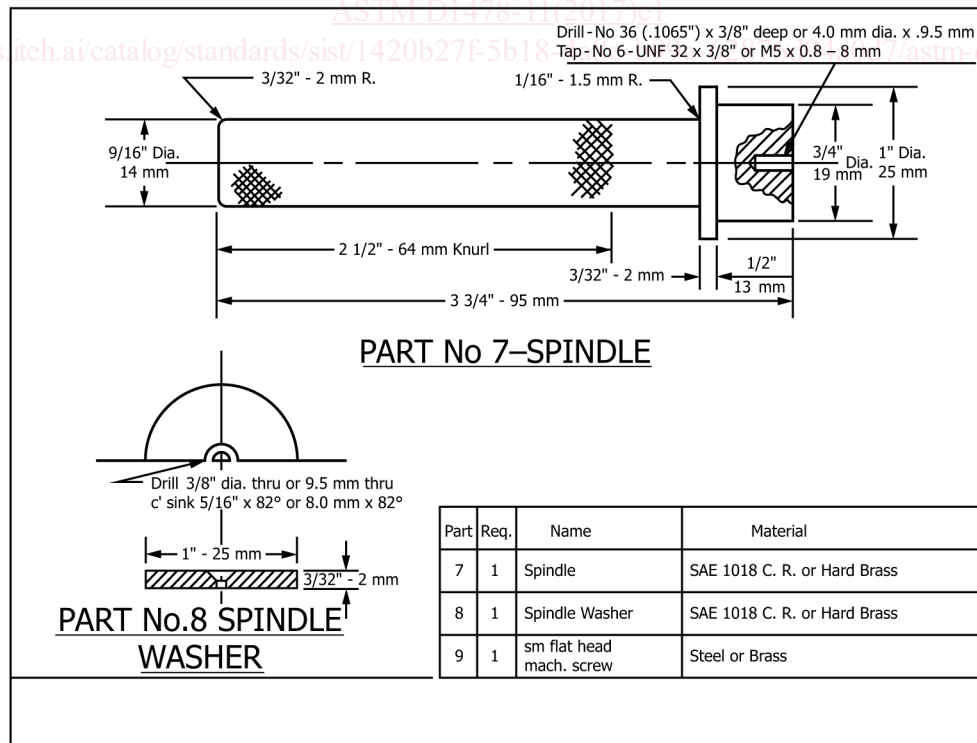

FIG. 4 Spindle