



Designation: D6344 – 04 (Reapproved 2017)

Standard Test Method for Concentrated Impacts to Transport Packages¹

This standard is issued under the fixed designation D6344; the number immediately following the designation indicates the year of original adoption or, in the case of revision, the year of last revision. A number in parentheses indicates the year of last reapproval. A superscript epsilon (ϵ) indicates an editorial change since the last revision or reapproval.

1. Scope

1.1 This test method covers procedures and equipment for testing complete filled transport packages for resistance against concentrated low-level impacts typical of those encountered in the distribution environment. The test is most appropriate for packages such as thin fluted/lighter grade corrugated boxes or stretch-wrapped packaging.

1.2 The test result is a pass/fail determination, based on acceptance criteria previously established, and a record of the energy dissipated by the complete filled transport package during a low level concentrated impact.

NOTE 1—This test method discusses the conduct of the test from a prescribed height that either meets or does not meet specific acceptance criteria. It may be possible to conduct this type of testing using modified procedures that provide a numerical response. These might include an incremental test where the drop height (or mass) is increased until a specific failure occurs or an up-and-down or staircase procedure used to find the average height to failure.

1.3 *This standard does not purport to address all of the safety concerns, if any, associated with its use. It is the responsibility of the user of this standard to establish appropriate safety and health practices and determine the applicability of regulatory limitations prior to use.*

1.4 *This international standard was developed in accordance with internationally recognized principles on standardization established in the Decision on Principles for the Development of International Standards, Guides and Recommendations issued by the World Trade Organization Technical Barriers to Trade (TBT) Committee.*

2. Referenced Documents

2.1 *ASTM Standards:*²

[D996 Terminology of Packaging and Distribution Environments](#)

¹ This test method is under the jurisdiction of ASTM Committee D10 on Packaging and is the direct responsibility of Subcommittee D10.21 on Shipping Containers and Systems - Application of Performance Test Methods.

Current edition approved May 1, 2017. Published July 2017. Originally approved in 1998. Last previous edition approved in 2009 as D6344 – 04 (2009). DOI: 10.1520/D6344-04R17.

² For referenced ASTM standards, visit the ASTM website, www.astm.org, or contact ASTM Customer Service at service@astm.org. For Annual Book of ASTM Standards volume information, refer to the standard's Document Summary page on the ASTM website.

[D4169 Practice for Performance Testing of Shipping Containers and Systems](#)

[D4332 Practice for Conditioning Containers, Packages, or Packaging Components for Testing](#)

[E122 Practice for Calculating Sample Size to Estimate, With Specified Precision, the Average for a Characteristic of a Lot or Process](#)

3. Terminology

3.1 *Definitions*—General definitions for the packaging and distribution environments are found in Terminology [D996](#).

3.2 *Definitions of Terms Specific to This Standard:*

3.2.1 *acceptance criteria*—the acceptable condition of package and contents that must be met after the shipping container has been tested.

4. Significance and Use

4.1 This test method is intended to evaluate the ability of packaging to resist the force of concentrated impacts from outside sources, such as those encountered in various modes of transportation and handling. These impacts may be inflicted by adjacent freight jostling against the package in a carrier vehicle, by accidental bumps against other freight when loaded or unloaded from vehicles, by packages bumping against one another during sorting on conveyors or chutes, or many other circumstances.

4.2 This test method is intended to determine the ability of packaging to protect contents from such impacts, and to evaluate if there is sufficient clearance or support or both between the package wall and its contents.

5. Apparatus

5.1 *Cylindrical Mass with Full Radius (Hemispherical) End*—Solid steel rod 32 mm \pm 2 mm (1.25 in. \pm 0.1 in.) in diameter, approximately 115 mm (4.5 in.) long, one end rounded to form a hemisphere, with a mass of 680 \pm 15 g (1.5 \pm 0.03 lb). A threaded eye-bolt may be attached to the end for positioning and support prior to guided free fall drop, but it must be included in the 680 g (1.5 lb) mass (see [Fig. 1](#)). Threaded eyebolts must be attached to the side for positioning and support when used as a pendulum, and must be included in the 680 g (1.5 lb) mass.

5.2 *Guided Free Fall* (see [Fig. 2](#)):

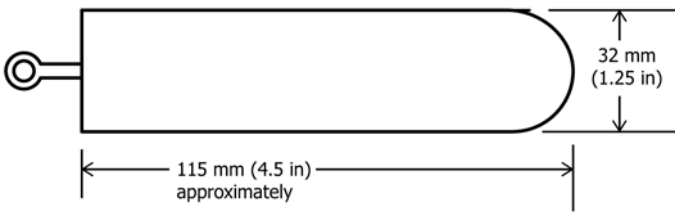

FIG. 1 Cylindrical Mass (steel rod)

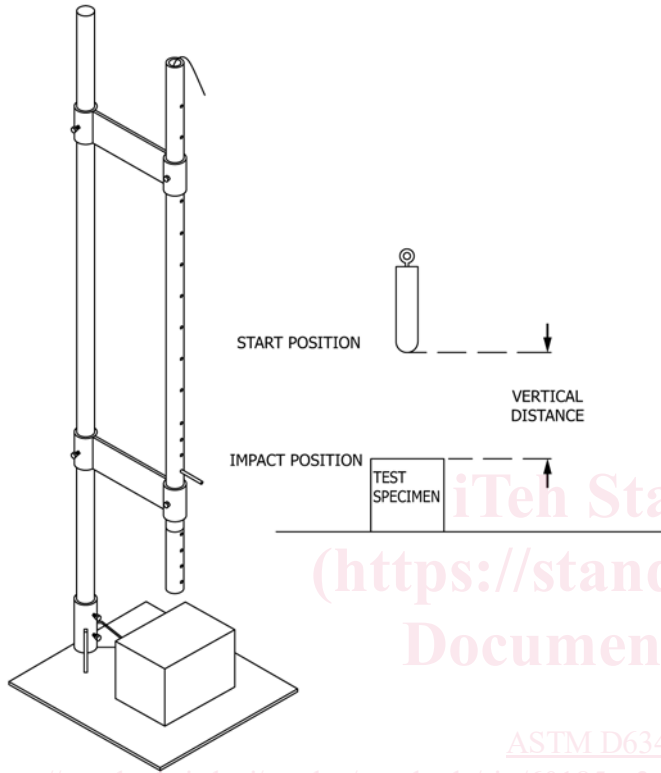

FIG. 2 Guided Free Fall

5.2.1 The cylindrical mass (rod) is held in a start position in a stiff tube of at least 38 mm (1.5 in.) diameter, such that the tube's main axis is perpendicular within 2 degrees. The end of the tube should be positioned 50 to 100 mm (2 to 4 in.) above the test specimen. The mass may be held in position, at the specified vertical distance, with either a string from the top of the tube, or by a support pin placed through the side of the tube.

5.2.2 The mass is allowed to fall freely when released to strike the test specimen with its rounded end. The free falling rod must strike the test surface within 10 mm (0.4 in.) of the desired point of impact. The test surface must be perpendicular to the direction of the falling mass.

5.3 Non-guided Free Fall:

5.3.1 If greater precision of impact velocity is desired, the cylindrical mass (rod) may be dropped without guidance of a tube. Means of suspending the mass and its release must be such that accuracy of positioning (drop height and impact point) are not affected.

5.3.2 The free falling rod must strike the test surface within 10 mm (0.4 in.) of the desired point of impact. The test surface must be perpendicular to the direction of the falling mass.

5.4 Pendulum (see Fig. 3):

5.4.1 Two cords suspend the steel rod described in 5.1, such that it may be swung as a pendulum from a specified vertical distance. The length of pendulum cords shall be at least 2 m (79 in.). Cords must be secured in the eyebolts to prevent slippage during test. The swinging rod must strike the test surface within 10 mm (0.4 in.) of the desired point of impact. The test surface must be perpendicular to the direction of the falling mass.

5.4.2 The test specimen must be braced securely so it does not move when impacted.

5.5 Conditioning Apparatus—Adequate facilities shall be provided for conditioning test specimens at the proper humidity and temperature prior to testing.

5.5.1 It is recommended that atmospheres for conditioning be selected from those given in Practice D4332. Unless otherwise specified, fiberboard or paperboard containers shall be conditioned in accordance with the preconditioning and standard conditioning atmospheres specified in Practice D4332.

6. Sampling

6.1 The test specimens and number of samples shall be chosen to permit an adequate determination of representative performance. Practice E122 is recommended.

7. Test Specimen

7.1 It is preferable to prepare the package with the actual contents for which it was designed (see Note 2). Close the package in the same manner that will be used in preparing it for shipment.

NOTE 2—Where the use of actual goods is not feasible because of excessive cost or danger, a dummy load simulating the goods may be used, provided the dummy load has the same exterior surfaces as the actual goods and interior packaging materials are the same as those in actual use.

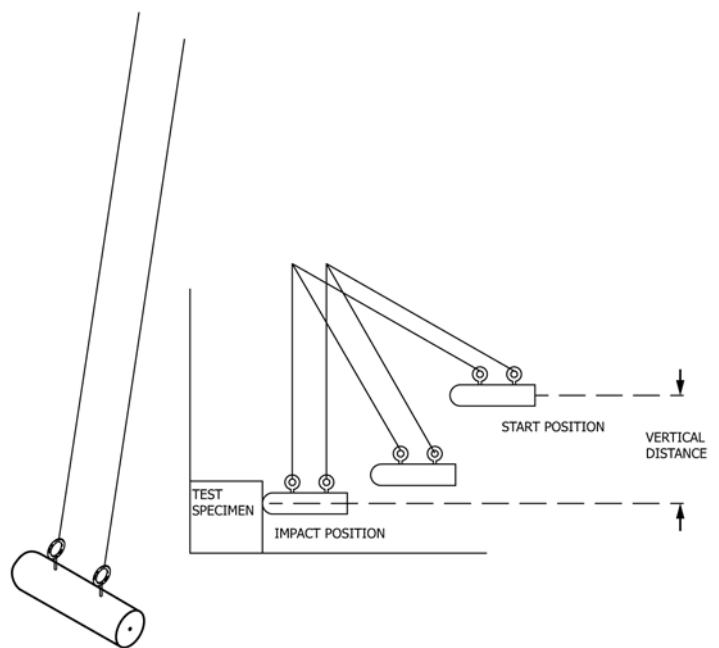

FIG. 3 Pendulum