



Designation: ~~D473 – 07 (Reapproved 2012)~~<sup>ε1</sup> D473 – 07 (Reapproved 2017)



Manual of Petroleum Measurement Standards (MPMS), Chapter 10.1

## Standard Test Method for Sediment in Crude Oils and Fuel Oils by the Extraction Method<sup>1</sup>

This standard is issued under the fixed designation D473; the number immediately following the designation indicates the year of original adoption or, in the case of revision, the year of last revision. A number in parentheses indicates the year of last reapproval. A superscript epsilon ( $\epsilon$ ) indicates an editorial change since the last revision or reapproval.

*This standard has been approved for use by agencies of the U.S. Department of Defense.*

---

<sup>ε1</sup> NOTE—IP information was removed editorially in March 2016.

---

### 1. Scope

1.1 This test method covers the determination of sediment in crude oils and fuel oils by extraction with toluene. The precision applies to a range of sediment levels from ~~0.01~~0.01 % to 0.40 % mass, although higher levels may be determined.

NOTE 1—Precision on recycled oils and crankcase oils is unknown and additional testing is required to determine that precision.

1.2 The values stated in SI units are to be regarded as standard. No other units of measurement are included in this standard.

1.3 *This standard does not purport to address all of the safety concerns, if any, associated with its use. It is the responsibility of the user of this standard to establish appropriate safety and health practices and determine the applicability of regulatory limitations prior to use.* For specific warning statements, see 5.1.1.6 and 6.1.

1.4 *This international standard was developed in accordance with internationally recognized principles on standardization established in the Decision on Principles for the Development of International Standards, Guides and Recommendations issued by the World Trade Organization Technical Barriers to Trade (TBT) Committee.*

### 2. Referenced Documents

2.1 *ASTM Standards:*<sup>2</sup>

D4057 Practice for Manual Sampling of Petroleum and Petroleum Products (API MPMS Chapter 8.1)

D4177 Practice for Automatic Sampling of Petroleum and Petroleum Products (API MPMS Chapter 8.2)

D5854 Practice for Mixing and Handling of Liquid Samples of Petroleum and Petroleum Products (API MPMS Chapter 8.3)

E29 Practice for Using Significant Digits in Test Data to Determine Conformance with Specifications

2.2 *API Standards:*<sup>3</sup>

Chapter 8.1 Manual Sampling of Petroleum and Petroleum Products (ASTM Practice D4057)

Chapter 8.2 Automatic Sampling of Petroleum and Petroleum Products (ASTM Practice D4177)

Chapter 8.3 Mixing and Handling of Liquid Samples of Petroleum and Petroleum Products (ASTM Practice D5854)

2.3 *ISO Standard:*<sup>4</sup>

5272 Toluene for industrial use—Specifications

### 3. Summary of Test Method

3.1 Extract test portion of a representative oil sample, contained in a refractory thimble, with hot toluene until the residue reaches constant mass. The mass of residue, calculated as a percentage, is reported as *sediment by extraction*.

---

<sup>1</sup> This test method is under the jurisdiction of ASTM Committee D02 on Petroleum Products, Liquid Fuels, and Lubricants and the API Committee on Petroleum Measurement, and is the direct responsibility of Subcommittee D02.02 /COMQ on Hydrocarbon Measurement for Custody Transfer (Joint ASTM-API).

Current edition approved Nov. 1, 2012; June 1, 2017. Published December 2012; July 2017. Originally approved in 1938. Last previous edition approved in 2007 as D473D473 – 07 (2012)<sup>ε1</sup>–07. DOI: 10.1520/D0473-07R12E01.10.1520/D0473-07R17.

<sup>2</sup> For referenced ASTM standards, visit the ASTM website, www.astm.org, or contact ASTM Customer Service at service@astm.org. For *Annual Book of ASTM Standards* volume information, refer to the standard's Document Summary page on the ASTM website.

<sup>3</sup> Available from American Petroleum Institute (API), 1220 L. St., NW, Washington, DC 20005-4070, <http://api-ec.api.org>.

<sup>4</sup> Available from American National Standards Institute (ANSI), 25 W. 43rd St., 4th Floor, New York, NY 10036, <http://www.ansi.org>.

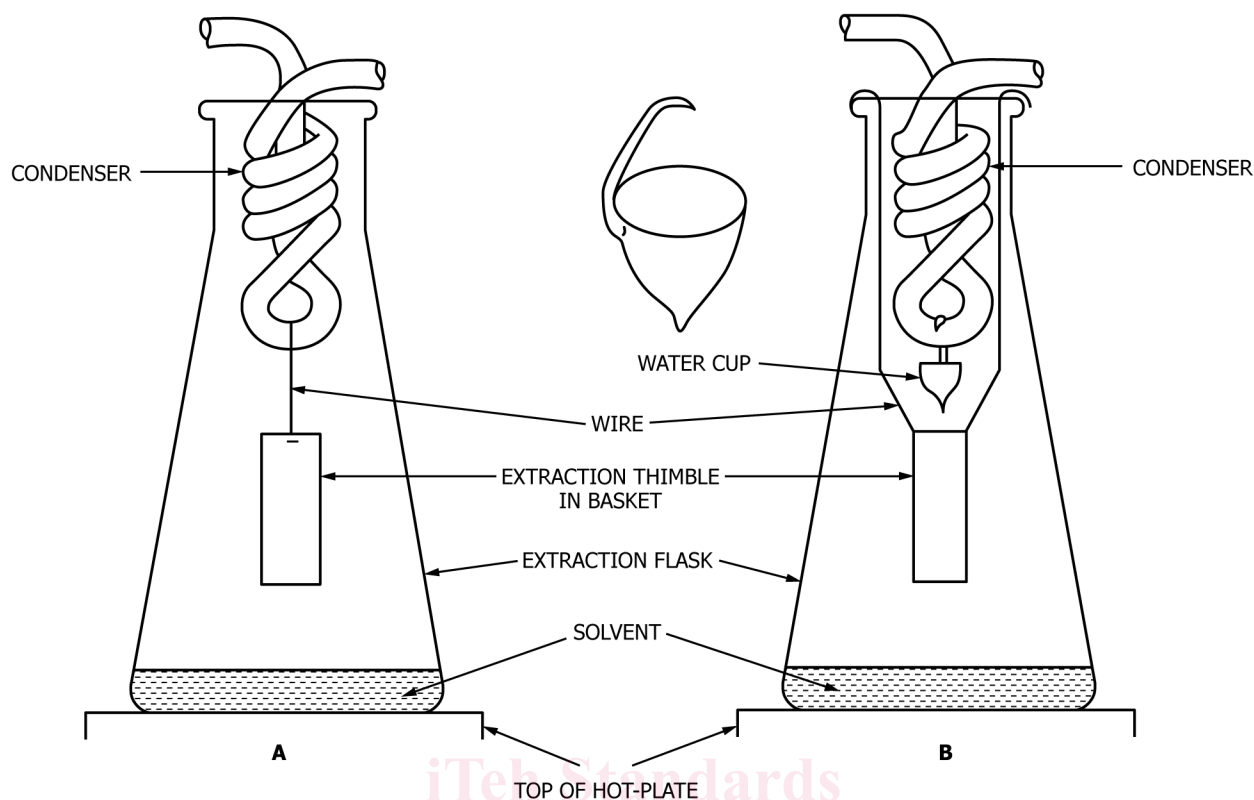

NOTE 1—Apparatus B shows the water cup in position.

FIG. 1 Extraction Apparatus for Determination of Sediment

#### 4. Significance and Use

4.1 A knowledge of the sediment content of crude oils and fuel oils is important both to the operation of refining and the buying or selling of these commodities.

#### 5. Apparatus

5.1 Usual laboratory apparatus and glassware, together with the following are required for this test method.

5.1.1 *Extraction Apparatus*—Use the apparatus illustrated in Figs. 1 and 2 and consisting of the elements described in 5.1.1.1 – 5.1.1.3.

5.1.1.1 *Extraction Flask*—Use a wide-neck (Erlenmeyer) flask of 1-L capacity, with a minimum external neck diameter of 50 mm, 50 mm, for the procedure.

5.1.1.2 *Condenser*—A condenser in the form of a metal coil approximately 25 mm-25 mm in diameter and 50 mm-50 mm in length attached to, and with the ends projecting through, a lid of sufficient diameter to cover the neck of the flask as shown in Fig. 1. The coil shall be made from stainless steel, tin, tin-plated copper, or tin-plated brass tubing having an outside diameter of 55 mm to 8 mm-8 mm and a wall thickness of 1.5 mm-1.5 mm. If constructed of tin-plated copper or brass, the tin coating shall have a minimum thickness of 0.075 mm-0.075 mm. The exposed surface of the coil for cooling purposes is about 115 cm<sup>2</sup>.

NOTE 2—The use of a water flowmeter/controller unit that monitors water flow to the condenser that shuts off the heat source when the flow rate drops below a pre-set limit has been found suitable to prevent vaporized toluene from igniting. The use of such a device is recommended.

5.1.1.3 *Extraction Thimble*<sup>5</sup>—The extraction thimble shall be of a refractory porous material, pore size 20.0 μm to 30.0 μm 30.0 μm (as certified by the manufacturer), 25 mm-25 mm in diameter by 70 mm-70 mm in height, weighing not less than 15 g 15 g and not more than 17 g-17 g. Suspend the thimble from the condenser coil by means of a basket so that it hangs approximately midway between the surface of the extracting solvent and the bottom of the condenser coil.

5.1.1.4 *Thimble Basket*—The thimble basket shall be corrosion-resistant and shall be made of platinum, stainless steel, nickel-chromium alloy, or similar material. Fig. 2 shows the design and dimensions of two typical baskets that have been used successfully in the industry.

<sup>5</sup> The sole source of supply of the extraction thimble, AN 485, 25 mm × 70 mm, coarse porosity, drawing number QA 005163, known to the committee at this time is Saint-Gobain/Norton Industrial Ceramics Corporation of Worcester, MA. If you are aware of alternative suppliers, please provide this information to ASTM International Headquarters. Your comments will receive careful consideration at a meeting of the responsible technical committee,<sup>1</sup> which you may attend.

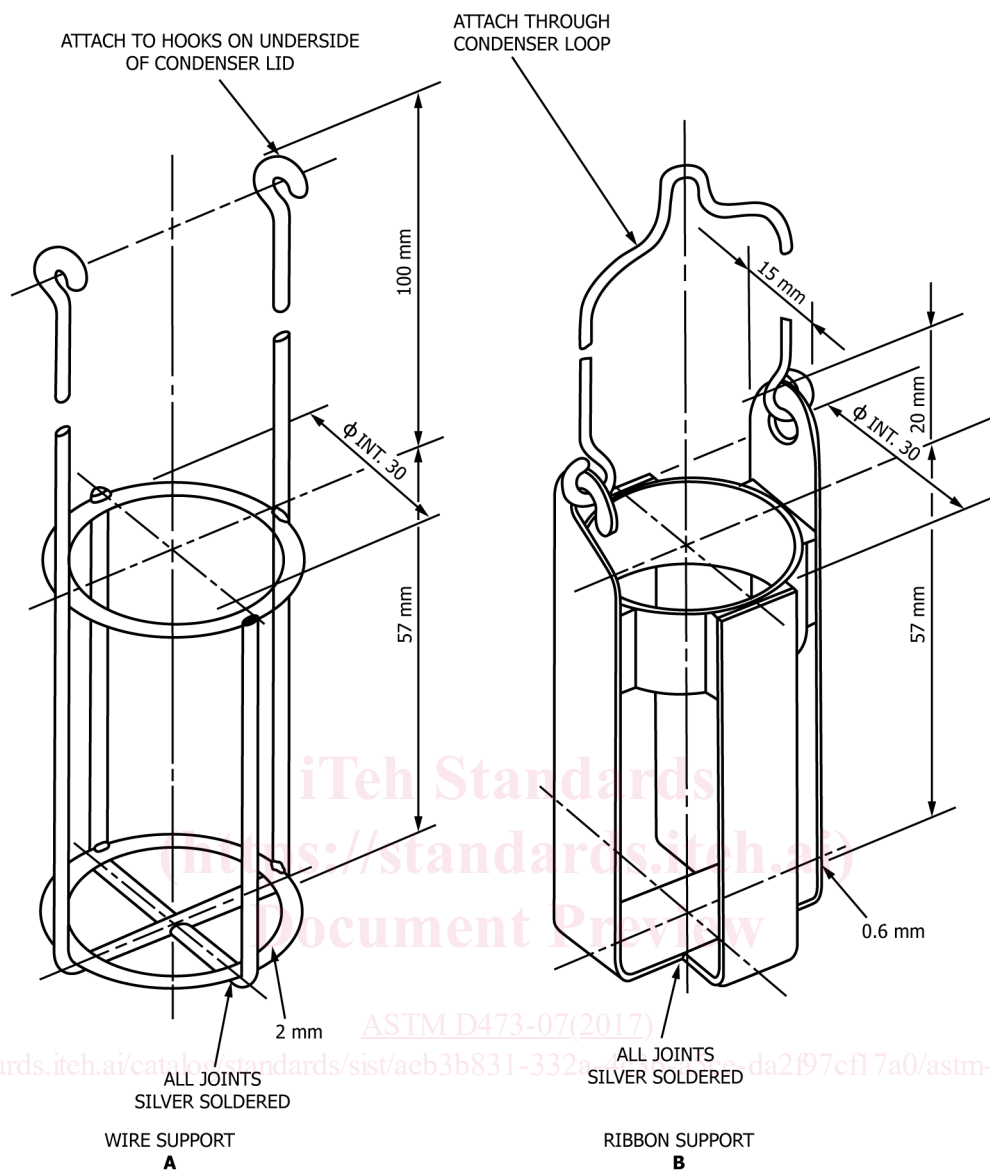

FIG. 2 Basket Thimble Support

5.1.1.5 *Water Cup*—Use a water cup when testing a sample determined to have a water content greater than 10 % volume (see Fig. 1, Apparatus B). The cup shall be made of glass, conical in shape, approximately 20 mm–20 mm in diameter and 25 mm–25 mm deep, and have a capacity of approximately 3 mL–3 mL. A glass hook fused on the rim at one side is so shaped that when hung on the condenser the cup hangs with its rim reasonably level. In this procedure, suspend the thimble basket as shown in Fig. 1, Apparatus A by means of the corrosion-resistant wire looped over the bottom of the condenser coil and attached to the basket supports, or as in Fig. 1, Apparatus B, where the wire supports of the basket are attached to hooks soldered to the underside of the condenser lid.

5.1.1.6 *Source of Heat*—Use a source of heat, preferably a hot plate operated under a ventilated hood, suitable for vaporizing toluene (**Warning—Warning Flammable.**)—Flammable.)

5.2 *Analytical Balance*—Use an analytical balance, with an accuracy of 0.1 mg–0.1 mg. Verify the balance, at least annually, against weights traceable to a national standards body such as the National Institute of Standards and Technology (NIST).

5.3 *Non-aerating Mixer*—Use a non-aerating mixer, meeting the verification of mixing efficiency requirements specified in Practice D5854 (API Chapter 8.3). Either insertion mixers or circulating mixers or circulating external mixers are acceptable provided they meet the criteria in Practice D5854 (API Chapter 8.3).

5.4 *Oven*—Use an oven capable of maintaining a temperature of  $\pm 5$  115 °C to  $\pm 20$  °C (240 120 °C (240 °F to 250 °F); 250 °F).

5.5 *Cooling Vessel*—Use a desiccator without desiccant as a cooling vessel.