International Standard



4054

INTERNATIONAL ORGANIZATION FOR STANDARDIZATION • МЕЖДУНАРОДНАЯ ОРГАНИЗАЦИЯ ПО СТАНДАРТИЗАЦИИ • ORGANISATION INTERNATIONALE DE NORMALISATION

Couplers, loose spigots and base-plates for use in working scaffolds made of steel tubes – Requirements and test procedure

Raccords, goujons d'assemblage et semelles pour échafaudages de service en tubes d'acier – Spécifications et méthodes d'essai

First edition – 1980-04-15

iTeh STANDARD PREVIEW
(standards.iteh.ai)

ISO 4054:1980

<https://standards.iteh.ai/catalog/standards/sist/582173e6-bbfb-468c-a009-d5ee2908e2d5/iso-4054-1980>

To be withdrawn

UDC 69.057.693

Ref. No. ISO 4054-1980 (E)

Descriptors : buildings, scaffolds, steel tubes, pipe fittings, equipment specifications, quality control, sampling, mechanical tests, designations, marking.

Price based on 13 pages

FOREWORD

ISO (the International Organization for Standardization) is a worldwide federation of national standards institutes (ISO member bodies). The work of developing International Standards is carried out through ISO technical committees. Every member body interested in a subject for which a technical committee has been set up has the right to be represented on that committee. International organizations, governmental and non-governmental, in liaison with ISO, also take part in the work.

Draft International Standards adopted by the technical committees are circulated to the member bodies for approval before their acceptance as International Standards by the ISO Council.

International Standard ISO 4054 was developed by Technical Committee ISO/TC 5, *Metal pipes and fittings*, and was circulated to the member bodies in November 1977.

(standards.iteh.ai)

It has been approved by the member bodies of the following countries :

Austria	India	ISO 4054:1980	Poland
Belgium	Israel	https://standards.iteh.ai/catalog/standards/sist/582173e6-bbfb-468c-a009-d5ee2908e2d5/iso-4054-1980	Romania
Chile	Italy		South Africa, Rep. of
Egypt, Arab Rep. of	Korea, Rep. of		Switzerland
Finland	Mexico		Turkey
France	Netherlands		USSR
Germany, F.R.	Norway		

The member bodies of the following countries expressed disapproval of the document on technical grounds :

Australia
Czechoslovakia
New Zealand
Sweden
United Kingdom

Couplers, loose spigots and base-plates for use in working scaffolds made of steel tubes — Requirements and test procedure

1 SCOPE AND FIELD OF APPLICATION

This International Standard specifies the requirements for materials and design, and test procedures and methods, for couplers, loose spigots and base-plates used for connecting steel tubes of 48,3 mm outside diameter and of at least 3,2 mm nominal wall thickness at a minimum in the construction of working scaffolds required for the construction, maintenance, repair and demolition of buildings and structures.

The requirements and test procedures specified are for the assessment of prototypes¹⁾ of these couplers, loose spigots and base-plates.²⁾

When no alteration has been made to the design, material or surface treatment of a type of coupler which has been approved as a prototype according to this International Standard, the assessment of subsequent production is made by comparison with the requirements given in this International Standard.

2 REFERENCES

ISO 404, *Steel and steel products — General technical delivery requirements.*³⁾

ISO/R 752, *Zinc ingots.*

ISO 2859 (and its addendum 1), *Sampling procedures and tables for inspection by attributes.*

ISO 3207, *Statistical interpretation of data — Determination of a statistical tolerance interval.*

ISO 3951, *Sampling procedure and charts for inspection by variables for percent defective.*⁴⁾

3 DEFINITIONS

For the purpose of this International Standard, the following definitions apply :

3.1 coupler : A component used for connecting two tubes.

3.2 right angle coupler : A coupler used for connecting two tubes crossing at a right angle.

3.3 swivel coupler : A coupler used for connecting two tubes crossing at any angle.

3.4 parallel coupler : A coupler used for connecting two parallel tubes.

3.5 sleeve coupler : A coupler used for joining two tubes located co-axially and whose purpose is to transmit only tensile and compressive forces.

There are two types of sleeve couplers :

3.5.1 sleeve couplers functioning by friction.

3.5.2 sleeve couplers working in shear.

3.6 loose spigot : An internal component used for aligning tubes co-axially and able to transmit compressive forces.

1) For the purpose of this International Standard, a "prototype" is a representative coupler, loose spigot or base-plate of a new or old design submitted for the first time to specific tests specified in this standard.

2) Allowable working loads shall be obtained from other appropriate documents.

3) At present at the stage of draft. (Revision of ISO/R 404-1964.)

4) At present at the stage of draft.

3.7 base-plate : A rigid plate used for spreading a load over a greater area.

If it has a means of vertical adjustment, it is called an "adjustable base-plate". This type of base plate is not covered by this International Standard.

4 SYMBOLS

4.1 Measured values

f = displacement in millimetres in figure 4

Δ = displacement in millimetres in figure 5

P = load in kilonewtons

L = specified lower limit for a load-bearing capacity or ultimate load in kilonewtons

φ = angle of rotation in degrees

Δ_1 = displacement of the transverse tube under load relative to the basic tube in figure 3a) and figure 3b), or the relative displacement of two tubes in figure 6

Δ_2 = displacement of the rear of the coupler fixed to the basic tube relative to the basic tube in figures 3a) 3b) and 6

Δ_3 = displacement of the transverse tube relative to the basic tube resulting from the play of the swivel joint pin in figure 3b)

$P_{max}(\Delta_1)$ = maximum load-bearing capacity of the coupler in the displacement range $\Delta_1 = 0$ to 7,0 mm for right angle and swivel couplers or 0 to 2,0 mm in the case of parallel couplers

$P_{max}(\Delta_2)$ = maximum load-bearing capacity of the coupler (slipping load) in the displacement range $\Delta_2 = 0$ to 0,5 mm

$L(\Delta_1), L(\Delta_2)$ = specified lower limit for $P_{max}(\Delta_1)$ or $P_{max}(\Delta_2)$ in table 1, column 5

$P = f(\Delta_1)$
 $P = f(\Delta_2)$ } = relationship of load P to displacement Δ_1 or Δ_2 (load-displacement curve)

Subscript j = the running subscript j , found in $\Delta_j, P(\Delta_j), L(\Delta_j)$ stands for the figures $j = 1, 2, \dots$; thus Δ_j means Δ_1 and Δ_2 , etc.

4.2 Statistical values

N = batch size

n_a = size of random sample taken from a batch for inspection by attributes

n_v = size of random sample taken from a batch for inspection by variables

\bar{x} = mean load in kilonewtons estimated from a series of i measurements (measurements of forces) for $P_{max, i}(\Delta_j)$

$$\bar{x} = \frac{1}{n_v} \sum_{i=1}^{n_v} P_{max, i}(\Delta_j)$$

$\bar{x}(\Delta_1), \bar{x}(\Delta_2)$ = mean value of a series of measurements for $P_{max}(\Delta_1)$ or $P_{max}(\Delta_2)$

s = standard deviation of force values in kilonewtons estimated from a series of i measurements (measurements of forces)

$$s = \sqrt{\frac{\sum_{i=1}^{n_v} [P_{max, i}(\Delta_j) - \bar{x}]^2}{n_v - 1}}$$

$s(\Delta_1), s(\Delta_2)$ = estimate of the standard deviation from a set of measurements of $P_{max}(\Delta_1)$, or $P_{max}(\Delta_2)$

k_s = the coefficient for the one-sided statistical tolerance (unknown standard deviation σ) based on sample size n_v . The interval confidence level $(1 - \alpha)$ is the probability that the statistical tolerance interval will contain at least a proportion q of the population (see ISO 3207). The interval is also a function of the estimate s of the standard deviation

$$k_s = k_2(n_v, q, 1 - \alpha)$$

z = test value of a series of measurements in kilonewtons, for comparison with a specified lower limit :

$$z = \bar{x} - k_s \times s$$

$z(\Delta_1), z(\Delta_2)$ = test value of a series of measurements of $P_{max}(\Delta_1)$ or $P_{max}(\Delta_2)$

A_c = acceptance number of a sampling plan for inspection by attributes, the choice of plan depending on the operating characteristic curve (see ISO 2859)

p = the average percent defective of product in batches submitted by the supplier for inspection (see ISO 2859)

d = number of defectives found in a sample

P_a = probability of acceptance of a batch (of size N) in percent. For a given sampling plan, P_a is a function of the percent defective p in the batch being submitted (see 8.2.3)

5 MATERIALS AND DESIGN

5.1 Materials

All components shall be made of appropriate, if possible standardized, material such as forged steel, rolled steel, malleable cast iron, or cast steel. The material shall be free from any impurities and defects which might affect its satisfactory use, and the components shall either be made of corrosion-resistant material or be protected against oxidation and corrosion.

5.2 Design

5.2.1 Couplers

5.2.1.1 Couplers shall be designed and manufactured so that they will firmly fix tubes together even after repeated use.

5.2.1.2 Where a coupler is fixed to a tube with a diameter which is at the lower tolerance limit, the clamping device shall have at least 2,0 mm of travel remaining after tightening. For a wedge coupler, there shall be equivalent unused travel.

5.2.1.3 In normal use, the tube shall not be damaged by the couplers. However, slight local indentations and/or deformations are permitted.

5.2.1.4 The various parts of the coupler shall be firmly attached to each other unless the design precludes this and it is impossible for the coupler under load to remain in position on the tubes without all its parts.

5.2.1.5 Neither the wedge nor the end of the bolt should directly touch the tube in order to tighten the fitting unless the contact of wedge or bolt along the tube is greater than 20 mm in all cases. If necessary a permanently attached spacer shall be incorporated to protect the tube.

5.2.1.6 A coupler which is secured by means of a screw shall be so constructed that it will perform satisfactorily when tightened as follows :

Tightening torques shall be indicated by the manufacturer and preferably shall be between 40 and 80 N·m. For types of couplers where hexagonal nuts are used with ISO threads, the following tightening torques are preferred :

- a) width across flats 22 mm : 50 N·m¹⁾
- b) width across flats 24 mm : 80 N·m.

When tightened with these torques, the maximum stress in screwed components shall not be greater than 70 % of the yield stress of the material.

Couplers secured with a wedge shall be tightened by striking the wedge with a 500 g hammer, until there is a jarring blow.

5.2.1.7 In addition, sleeve couplers shall be such that the tubes are co-axial. The sleeve shall be long enough to grip at least a 46 mm length of each of the two tubes.

5.2.2 Loose spigots

Loose spigots shall extend to a depth of at least 75 mm into the tubes on both sides of the flange. The outside diameter of flanges shall be not greater than 47,8 mm and not less than 47,0 mm. The circumscribing circle of the body shall have a diameter of not greater than 37,5 mm and not less than 35,0 mm, with the exception of cross-shaped bodies, which may have a maximum diameter of 40,5 mm.²⁾ The flange and spigot axis shall be concentric, and the tolerance on concentricity shall be 1,0 mm.

5.2.3 Rigid base-plates

Each base-plate shall have a circular or square base with an area not less than 150 cm². The thickness of the plate shall be at least 5 mm for base areas up to 175 cm²; if the base area is larger than this, the thickness shall be increased in proportion to the largest dimension of the base area. If the plate is shaped, the rigidity shall be equivalent to that of a flat base-plate.

5.2.3.1 The base-plate shall have a centring device which is so designed that it cannot move a distance greater than 11,0 mm within a bore of 43,0 mm internal diameter (see figure 1). The centring device shall be at least 50 mm long.

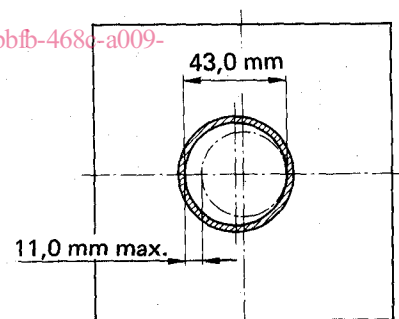

FIGURE 1 — Maximum clearance between centring device and tube

5.2.3.2 The base-plate including the centring device shall be made from material having a tensile strength of not less than 300 N/mm² and a yield stress of not less than 200 N/mm².

1) The 22 mm size is not in accordance with ISO 272.

2) For a transitional period and as long as tubes of thickness up to 4,05 mm are still available, it may be necessary to limit, for such tubes, the diameter of the circumscribing circle for cross-shaped bodies to 39,5 mm.

5.3 Data required from the manufacturer

The manufacturer shall record on drawings the following data for couplers, loose spigots and base-plates :

- a) shape;
- b) essential dimensions with tolerances;
- c) mass with tolerance;
- d) material characteristics;
- e) surface protection;
- f) the required tightening torque in the case of screw couplers;
- g) the maximum permissible play of the swivel joints in the case of swivel couplers.

6 SPECIFICATIONS

6.1 Design requirements

6.1.1 All couplers, loose spigots and base-plates shall comply with the relevant items in clause 5.

6.1.2 The dimensions, mass and material characteristics shall lie within the tolerances specified in the manufacturer's drawings referred to in 5.3. The surface protection shall be as specified in the manufacturer's drawings.

6.2 Required characteristics for couplers under load (see clause 9)

The requirements for prototype testing of couplers are listed in table 1.

6.2.1 Non-statistical assessment

Where a coupler (as specified in column 1 of table 1) is tested using one of the procedures in columns 2 and 3, the following limits shall apply in the case of non-statistical assessment :

- a) the load-bearing capacity or breaking load in column 4 shall not be less than the lower limit L or $L(\Delta_f)$ in column 5, in any test;
- b) the appropriate permissible displacement range Δ_f in column 6 shall not be exceeded in any test at the lower limit $L(\Delta_f)$ of the load-bearing capacity specified (column 5).

Column 7 of table 1 gives the minimum number of tests required.

6.2.2 Statistical assessment

Couplers are in accordance with this International Standard for their load-bearing capacity $P(\Delta_f)$ if it can be stated with a confidence level of 95 % that at least 90 % of the items in the batch from which the random sample was taken exhibit the same or better load-bearing capacity $P_{max}(\Delta_f)$ than the

specified lower limit $L(\Delta_f)$. Examples of assessment procedures which test acceptance to these requirements are indicated in 8.2.4 and 8.2.5.

Further assessment procedures which may also be applied are to be found in ISO 2859 (and its addendum 1), ISO 3207 and ISO 3951.

6.3 Requirements in the case of design alteration

Where alterations are made to the design, material or surface treatment of couplers which have already been submitted to a prototype test, a new test shall be made.

7 SAMPLING FOR PROTOTYPE TESTS

7.1 Sampling shall be carried out by an agreed representative of a competent authority or by an independent organization approved by the competent authority.

7.2 The test pieces required for prototype testing shall be taken at random (see ISO 2859, addendum 1) from a batch of at least 500 couplers obtained from the manufacturer's current production run or from stock.

7.3 The number of test pieces is specified in the description of the appropriate test procedure (see 9.2 to 9.8). In addition, the number is shown in column 8, table 1.

7.4 In statistical assessment, it may become necessary, depending on the operating characteristic and assessment procedure chosen, to test more couplers per batch than the minimum number indicated in column 8, table 1 (see also 8.2).

8 ASSESSMENT METHODS

8.1 Non-statistical assessment

8.1.1 Field of application

All tests so marked in column 9 of table 1 are not statistically assessed.

8.1.2 Criteria

a) All the loads measured in a given test series (for example breaking load as specified in column 4 of table 1) are compared with their specified lower limits (column 5 of table 1). No measurement shall be less than its lower limit, in any test.

b) When the displacement value is limited, then this displacement is measured under the load equal to the specified lower limit (column 6, table 1). No displacement value shall lie outside the permissible displacement range in any test (column 6, table 1).

TABLE 1 - Summary of requirements for behaviour under load in prototype testing of couplers specified in clauses 8 and 9

Column	1	2	3	4	5	6	7	8	9
Line	Type of coupler	Test procedure as in clause	figure	Qualities investigated	Lower limit of load-bearing capacity	Permissible range of displacement down to lower limit of bearing strength	Minimum number of tests	Minimum number of couplers required	Evaluation procedure
1.1	Right-angle coupler	9.2.2 or 9.2.3	3a	Load-bearing capacity rel. to Δ_1 ¹⁾	$L(\Delta_1) = 7,0$	$\Delta_1 \leq 7,05$	$n_a = 883$ $n_v = 503$	44	by attributes } by variables } statistical ⁴⁾
1.2	Right-angle coupler	9.2.2 or 9.2.3	3a	Load-bearing capacity rel. to Δ_2 (slipping load) ²⁾	$L(\Delta_2) = 10,0$	$\Delta_2 \leq 0,55$	$n_a = 883$ $n_v = 503$	25	by attributes } by variables } statistical ⁴⁾
1.3	Right-angle coupler	9.4	3c	Breaking load	$L = 20,0$	No specifications	10	10	non-statistical
1.4	Right-angle coupler	9.5	4	Rigidity of angle of rotation	No specifications	No specifications	10	10	non-statistical
2.1	Swivel coupler	9.3	3b	Load-bearing capacity rel. to Δ_1 ¹⁾	$L(\Delta_1) = 6,0$	$\Delta_1 \leq 7,05$	$n_a = 883$ $n_v = 503$	88	by attributes } by variables } statistical ⁴⁾
2.2	Swivel coupler	9.3	3b	Load-bearing capacity rel. to Δ_2 (slipping load) ²⁾	$L(\Delta_2) = 8,5$	$\Delta_2 \leq 0,55$	$n_a = 883$ $n_v = 503$	50	by attributes } by variables } statistical ⁴⁾
2.3	Swivel coupler	9.4	3c	Breaking load	$L = 17,0$	No specifications	10	10	non-statistical
3.1	Sleeve coupler with friction closure	9.6	5	Load-bearing capacity with 2 mm slipping distance	$L(\Delta) = 3,0$	$\Delta \leq 2,0$	25	25	non-statistical
4.1	Sleeve coupler with shear closure	9.7	5	Load-bearing capacity with 5 mm slipping distance	$L(\Delta) = 20,0$	$\Delta \leq 5,0$	105	10	non-statistical
4.2	Sleeve coupler with shear closure	9.7	5	Breaking load	$L = 50,0$	No specifications	105	10	non-statistical
5.1	Parallel coupler	9.8	6	Load-bearing capacity rel. to Δ_1 ¹⁾	$L(\Delta_1) = 15,0$	$\Delta_1 \leq 2,05$	$n_a = 883$ $n_v = 503$	176	by attributes } by variables } statistical ⁴⁾
5.2	Parallel coupler	9.8	6	Load-bearing capacity rel. to Δ_2 (slipping load) ²⁾	$L(\Delta_2) = 15,0$	$\Delta_2 \leq 0,55$	$n_a = 883$ $n_v = 503$	100	by attributes } by variables } statistical ⁴⁾
5.3	Parallel coupler	9.9	7	Breaking load	$L = 20,0$	No specifications	5	5	non-statistical

1) Corresponds in variable testing to $P_{max}(\Delta_1)$.

2) Corresponds in variable testing to $P_{max}(\Delta_2)$.

3) See 7.4, 8.2.4 or 8.2.5.

4) Statistical assessment in 8.2 required (see also flow diagram, table 4).

5) Both these measurements shall always be carried out in a single test.

8.2 Statistical assessment

8.2.1 Field of application

All tests so marked in column 9 of table 1 shall be statistically assessed.

8.2.2 Alternative methods

The method of inspection by attributes or the method of inspection by variables may be used for statistical acceptance.

In inspection by attributes it is only necessary to check whether or not the displacement Δ_j of the coupler exceeds a specified limiting value when subjected to a load $P = L(\Delta_j)$.

For inspection by variables, the value of the load-bearing capacity $P(\Delta_j)$ of every coupler in the sample is measured and a test quantity $z(\Delta_j)$ is calculated from the set of measurements: this must be greater than the lower limit specified for the load $L(\Delta_j)$ (see table 4). Inspection by variables is only permitted when the distribution of the test results does not differ significantly from normal, or the actual distribution can be transformed to a normal one.

The testing applicant, for example a manufacturer, is free to choose the method of analysis provided that both methods are applicable.

8.2.3 Operating characteristic curve (A curve showing,

for a given sampling plan, the probability of acceptance of a batch as a function of its actual quality).

8.2.3.1 Both test methods shall be based on the comparable operating characteristics (see ISO 2859, addendum 1).

8.2.3.2 For use in prototype testing, an operating characteristic which runs through both the following points is recommended (see figure 2):

$$p = 2\%; P_a = 97\%$$

$$p = 10\%; P_a = 5\%$$

There are similar operating characteristic curves in the ISO publications previously referred to.

8.2.3.3 Other operating characteristics, which in accordance with the requirement in 6.2.2 run through the range of points

$$p \leq 10\%; P_a = 5\%$$

and have a steeper curve than the operating characteristic recommended in 8.2.3.2, may also be used¹⁾.

For instance the following operating characteristic curves are in accordance with ISO 2859 (see figure 2):

Code letter L, AQL 2,5 (table 10 L)

Code letter M, AQL 4,0 (table 10 M)

For STANDARD REVIEW
(standards.iteh.ai)
ISO 4054:1980
<https://standards.iteh.ai/catalog/standards/sist/582173e6-bbfb-468c-a009-d5ee2908e2d5/iso-4054-1980>

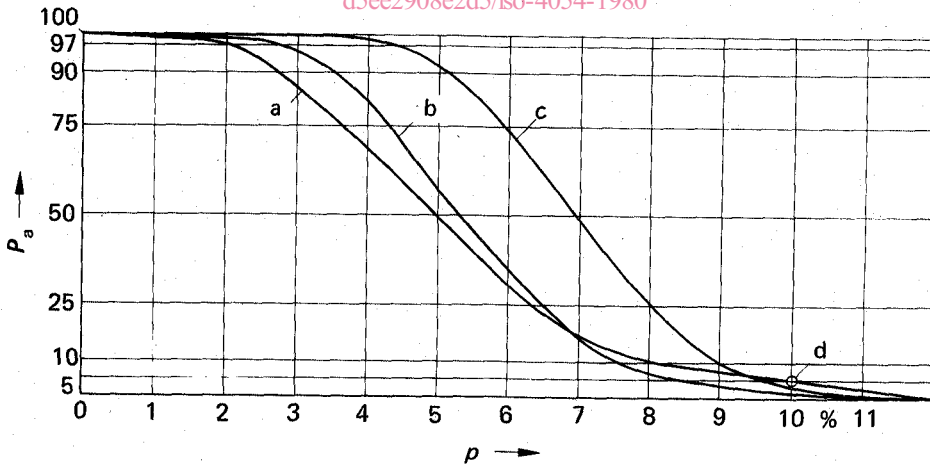

P_a = probability of acceptance
 p = percent defective
 a = curve as recommended in 8.2.3.2
 b = operating characteristic curve associated with sampling plan L, AQL 2,5 in ISO 2859
 c = operating characteristic curve associated with sampling plan M, AQL 4,0 taken from ISO 2859
 d = limiting point ($p = 10\%; P_a = 5\%$) as specified in 6.2.2 and 8.2.3.3.

FIGURE 2 — Operating characteristics

1) It may be that not all operating characteristic curves recommended in 8.2.3 will pass exactly through the point $P_a = 5\%$ and $p = 10\%$ (i.e. $1 - \alpha = 95\%$, $1 - p = 90\%$). Consequently they may not correspond directly with the factors n and k_2 in ISO 3207. They will, however, provide comparable protection in terms of the operating characteristics.

8.2.4 Sample plan with criterion for attributive test method

8.2.4.1 The size of the sample n_a and the acceptance number A_c for the attributive test method are listed in table 2 for the operating characteristics recommended in 8.2.3.

TABLE 2 – Examples of sampling plans for inspection by attributes

Operating characteristic	Sample size n_a	Acceptance number A_c
As recommended in 8.2.3.2	88	4
From ISO 2859		
L, AQL 2,5	200	10
M, AQL 4,0	315	21

8.2.4.2 If the operating characteristic curve recommended in 8.2.3.2 is used, the conditions of test will be satisfied provided, in a sample with $n_a = 88$, the number of defectives, d , does not exceed $A_c = 4$.

That means in general

for $d \leq A_c$ the batch is accepted;

for $d > A_c$ the batch is rejected.

8.2.4.3 The procedure of testing by attributes and its interpretation are summarized in the flow diagram given in table 4.

8.2.5 Sample plan with criteria for variable test method

8.2.5.1 A sample for which the test value $z(\Delta_j)$ is acceptable shall be deemed to conform to a normal distribution if not more than one individual test value $P(\Delta_j)$ out of a sample of 50 such values is less than the lower limit $L(\Delta_j)$.

8.2.5.2 In this normal distribution, unusually high values for the load-bearing capacity $P_{max}(\Delta_j)$ which are greater than the sum of the mean (\bar{x}) and three times the standard deviation ($3s$) may be made equal to the value $P_{max}(\Delta_j) = \bar{x} + 3s$.

8.2.5.3 If the curves recommended in 8.2.3 are used, sample sizes n_v and the factor k_s given in table 3 can be used.

TABLE 3 – Examples of sampling plans for inspection by variables

Operating characteristic	Sample size n_v	Factor k_s
As recommended in 8.2.3.2	50	1,65
As curve b in figure 2	103	1,62
As curve c in figure 2	170	1,49

8.2.5.4 From the series of measurements $P_{max}(\Delta_1)$, and $P_{max}(\Delta_2)$ (transformed if necessary) using the methods described in ISO 3207 the mean values (in kilonewtons)

$$\bar{x}(\Delta_1) \text{ and } \bar{x}(\Delta_2)$$

and the standard deviations (in kilonewtons)

$$s(\Delta_1) \text{ and } s(\Delta_2)$$

are estimated.

The test values (both in kilonewtons)

$$z(\Delta_1) = \bar{x}(\Delta_1) - k_s \times s(\Delta_1)$$

$$z(\Delta_2) = \bar{x}(\Delta_2) - k_s \times s(\Delta_2)$$

are calculated.

8.2.5.5 The test values $z(\Delta_1)$ and $z(\Delta_2)$, transformed back to original units if necessary, are compared with the limit load-bearing capacities $L(\Delta_1)$ and $L(\Delta_2)$.

If $z(\Delta_1) \geq L(\Delta_1)$ and $z(\Delta_2) \geq L(\Delta_2)$ the prototype is accepted.

If $z(\Delta_1) < L(\Delta_1)$ or $z(\Delta_2) < L(\Delta_2)$ the prototype is rejected.

8.2.5.6 The procedure of testing by variables and its interpretation is summarized in the flow diagram given in table 4.

9 LOAD TESTS FOR PROTOTYPE COUPLERS

9.1 General

9.1.1 The prototype tests shall be carried out by a competent authority or an independent organization which is approved by the competent authority.

With the exception of the torque spanner, all test equipment shall have an accuracy of $\pm 2\%$. The torque spanner shall have an accuracy of $\pm 5\%$.

9.1.2 New hot-galvanized scaffold tubes with quality of zinc Zn 98,5 defined in ISO/R 752 (with the following percentages of impurities: lead 1,4 – cadmium 0,20 – iron 0,05 – total 1,50) shall be used when performing the behaviour-under-load test on couplers. The mass of zinc per unit area shall be not less than 300 g/m². The tubes shall have an external diameter of $48,3 \pm 0,5$ mm, a wall thickness of $3,2 \pm 0,2$ mm and a yield stress of 270 ± 30 N/mm². The tubes, when tested, shall have a surface condition similar to that of a tube just after galvanizing.

9.1.3 New couplers shall be used for the tests. The couplers, when tested, shall have a surface condition similar to that of a coupler just after manufacture.