



Designation: F 1636 – 95^{ε2}

Standard Specification for Bores and Cones for Modular Femoral Heads¹

This standard is issued under the fixed designation F 1636; the number immediately following the designation indicates the year of original adoption or, in the case of revision, the year of last revision. A number in parentheses indicates the year of last reapproval. A superscript epsilon (ϵ) indicates an editorial change since the last revision or reapproval.

^{ε1} NOTE—Editorial changes were made throughout in December 1996.

^{ε2} NOTE—Tables 1 and 2 were editorially corrected in May 2001.

1. Scope

1.1 This specification covers the functional dimensions and tolerances for tapered cones of proximal femoral stems and the bores of mating ceramic and metal heads.

1.2 This specification does not cover the dimensions of proximal femoral stems other than the cone portion, nor does it cover the dimensions of the ceramic/metal femoral heads, other than the inside tapers.

1.3 The dimensions stated in SI units are to be regarded as the standard.

1.4 The purpose of this specification is to codify matching bore and cone combinations for easy identification. Nonetheless, components from different manufacturers should not be mixed because the combinations of tolerances within the family, surface finish, and configuration from the different manufacturers may not have been validated through axial load strengths or fatigue strength. Information supplied by the manufacturer with the implants should include a precaution statement that informs the user (surgeon) that bores and cones with the same code letter from different manufacturers should not be used without first consulting the supplier of the femoral components.

1.5 The codification described in this specification represents the most current state of the art at the time of balloting. Future additions can be made but because of the time required to revise the specification, it is recommended that the manufacturer of new combinations label their components with at least the angles until such time that new code letters can be established in accordance with future revisions of this specification.

2. Referenced Documents

2.1 ASTM Standards:

F 75 Specification for Cast-Cobalt-Chromium-Molybdenum Alloy for Surgical Implant Applications²

F 136 Specification for Wrought Titanium 6Al, 4V ELI

Alloy for Surgical Implant Applications²

F 138 Specification for Stainless Steel Bar and Wire for Surgical Implants (Special Quality)²

F 562 Specification for Wrought Cobalt-Nickel-Chromium-Molybdenum Alloy for Surgical Implant Applications²

F 563 Specification for Wrought Cobalt-Nickel-Chromium-Molybdenum-Tungsten-Iron Alloy for Surgical Implant Applications²

F 603 Specification for High-Purity Dense Aluminum Oxide for Surgical Implant Application²

F 620 Specification for Titanium 6Al, 4V ELI Alloy Forgings for Surgical Implants²

F 621 Specification for Stainless Steel Forgings for Surgical Implants²

F 799 Specification for Thermomechanically Processed Cobalt-Chromium-Molybdenum Alloy Forgings for Surgical Applications²

F 961 Specification for Cobalt-Nickel-Chromium-Molybdenum Alloy Forgings for Surgical Implant Applications²

F 1108 Specification for Ti-6Al, 4V Alloy Castings for Surgical Implants²

3. Terminology

3.1 Definitions:

3.1.1 *nominal neck length*—the distance, K , parallel to the taper axis, between the theoretical gage point and the horizontal plane through the center of the head; this distance does not include standard variants used to adjust for resection level, leg length, and so forth. The K dimension may be plus or minus (proximal or distal to the location of the theoretical gage Point G).

3.1.2 *residual or free length*—the distance, A , parallel to the cone axis, between the end of the cone and the theoretical gage point.

3.1.3 *theoretical gage point*—the diameter, G , at nominal tolerance, where the stem cone (external taper) theoretically engages the femoral head bore (internal taper).

4. Materials

4.1 The cones may be made from any of the implantable

¹ This specification is under the jurisdiction of ASTM Committee F04 on Medical and Surgical Materials and Devices and is under the direct responsibility of Subcommittee F04.22 on Arthroplasty.

Current edition approved Dec. 10, 1995. Published June 1996.

² *Annual Book of ASTM Standards*, Vol 13.01.

TABLE 1 Cones

α°	Size	G—Diameter, mm	A—Dimension, mm
2° 50' 30", ±50'	A	12.8	1.0
3° 4' 0", ±6'	B	10.98	2.54
4° 0' 0", ±2.5'	C	11.5	1.0
4° 0' 0", ±1.6'	D	13.3	1.0
5° 0' 0", ±3'	E	12.7	2.34
5° 35' 30", ±2'	F	11.75	0.0
	G	9.6	1.4
	H	10.3	1.0
	J	11.1	1.0
5° 40', +2.5'	K	11.87	5.75
	L	12.7	1.0
	M	12.7	1.4
	N	12.7	1.4
	P	14.3	1.0
	Q	14.3	1.4
	R	10.98	0.5
	S	11.082	1.5
5° 43' 30", ±2'	T	11.2	2.7
	U	11.082	3.0
	V	11.082	1.501
	W	11.082	1.502
6° 0' 00", +1'-0'	X	10.69	5.12
	Y	10.1	1.0
6° 0' 00", ±1' 5"	Z	10.9	1.0
	AA	12.5	1.0
	BB	14.1	1.0
6° 0' 00", ±4'	CC	10.69	5.12
6° 21' 34", +0'-5"	DD	12.0	7.0
11° 25' 00", +1'-2"	EE	11.1	3.8

grade materials used for femoral stems including: Specifications F 75, F 136, F 138, F 562, F 563, F 620, F 621, F 799, F 961, and F 1108.

4.2 The ceramic heads may be made from Specification F 603 or a material determined to be substantially equivalent or superior in mechanical strength, wear properties, and biocompatibility. The metal heads may be made from any of the recognized materials used for femoral stems including: Specifications F 75, F 136, F 138, F 562, F 563, F 620, F 621, F 799, F 961, and F 1108.

5. Dimensions and Finish

5.1 The cone dimensions shall be as indicated in Fig. 1 and Table 1. A gaging system should be used to ensure that mating diameters of the cone will allow proper seating of the femoral head.

5.2 The inside taper of the femoral head shall have the dimensions as indicated in Fig. 2 and Table 2. It is important with ceramic heads that the tip of the cone reside in the relief of the head on final assembly.

5.3 The finish of the cone may be textured, machined, ground, or roughened surface. The adequacy of this surface finish shall be tested for the axial strength of the head and the pull-off load.

6. Marking

6.1 Each cone and head shall be marked with the appropriate size letter to designate matching bores and cones and,

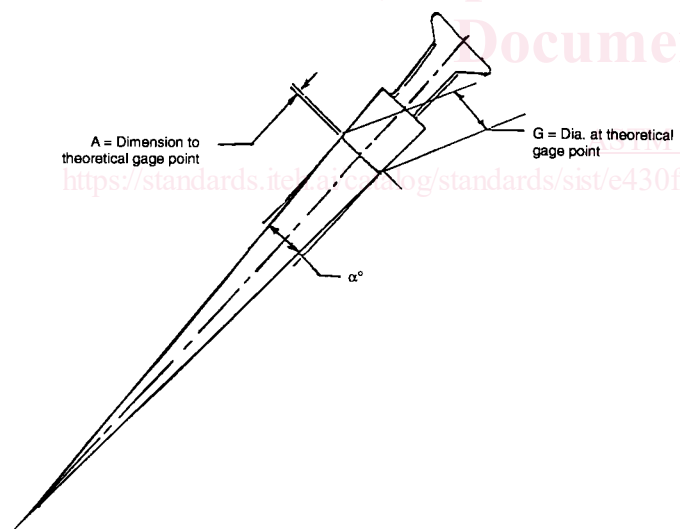

FIG. 1 Cones

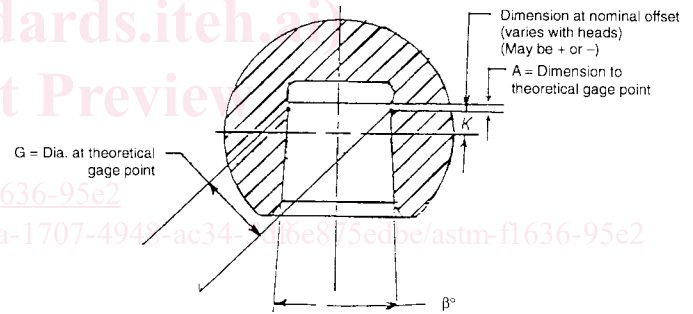

FIG. 2 Bores

where possible, the manufacturer's code or logo.

7. Keywords

7.1 bores; ceramic; cones; dimensions; femoral heads; finish; marking; metal; sizes