



Designation: ~~D1000~~—~~10~~ **D1000** – 17

Standard Test Methods for Pressure-Sensitive Adhesive-Coated Tapes Used for Electrical and Electronic Applications¹

This standard is issued under the fixed designation D1000; the number immediately following the designation indicates the year of original adoption or, in the case of revision, the year of last revision. A number in parentheses indicates the year of last reapproval. A superscript epsilon (ϵ) indicates an editorial change since the last revision or reapproval.

This standard has been approved for use by agencies of the U.S. Department of Defense.

1. Scope*~~Scope~~

1.1 These test methods cover procedures for testing pressure-sensitive adhesive-coated tapes to be used as electrical insulation. These tapes are classified as follows:

1.1.1 *Class 1*—Non-elastomeric backings made from materials such as:

- Paper, flat or creped,
- Fabric, uncoated or coated,
- Cellulose ester films,
- Polyethylene terephthalate (polyester) films,
- Fluorocarbon polymer films,
- Composite filament films,
- Polyamide films,
- Polyimide films, and
- Combinations thereof.

1.1.2 *Class 2*—Elastomeric backings that are characterized by both high stretch and substantial recovery. These backings are made from materials such as:

- Vinyl chloride and co-polymers,
- Vinylidene chloride and co-polymers, and
- Polyethylene and co-polymers.

1.2 Test laminates of Class 1 and Class 2 backings according to Class 1 test methods.

1.3 The procedures appear in the sections indicated below and in alphabetical order:

Adhesion Strength to Steel and Backing at Room Temperature	46 – 53
Adhesion Strength to Steel and Backing at Low Temperatures	46 – 53
Bond Strength After Solvent Immersion	110 – 115
Breaking Strength and Elongation at Room Temperature	37 – 45
Breaking Strength and Elongation at Low Temperatures	37 – 45
Conditioning	6 – 8
Curling and Twisting	140 – 146
Dielectric Breakdown Voltage	83 – 90
Effect of Accelerated Aging on High-Temperature Tapes	97 – 103
Flagging	66 – 76
Flammability	104 – 109
Hazards/Precautions	3
Insulation Resistance at High Humidity	91 – 96
Length of Tape in a Roll	28 – 36
Oil Resistance	116 – 122
Puncture Resistance	123 – 128
Resistance to Accelerated Aging (Heat and Moisture)	129 – 139
Sampling	4
Specimen Preparation	5
Thermosetting Properties	77 – 82
Thickness	21 – 27
Unwind Force at Room Temperature	54 – 65
Unwind Force at Low Temperatures	54 – 65
Width	11 – 20

¹ These test methods are under the jurisdiction of ASTM Committee D09 on Electrical and Electronic Insulating Materials and are the direct responsibility of Subcommittee D09.07 on Flexible and Rigid Electrical Insulating Materials.

Current edition approved Jan. 1, 2010 July 1, 2017. Published February 2010 July 2017. Originally approved in 1948. Last previous edition approved in 2009 2010 as ~~D1000~~D1000 – 10, –09; DOI: ~~10.1520/D1000-10~~10.1520/D1000-17.

***A Summary of Changes section appears at the end of this standard**

NOTE 1—These procedures apply to both Class 1 and Class 2 tapes except as noted above.

1.4 This is a ~~fire-test response standard~~ fire-test response standard (see Section 104).

1.5 The values stated in SI units are the standard, unless otherwise noted. If a value for measurement is followed by a value in inch-pound or English units in parentheses, it is likely that the second value may will only be approximate and it is for information only. The first stated value is the preferred unit.

NOTE 2—These test methods are similar to IEC 60454–3, but may differ sometimes in some details.

1.6 *This standard does not purport to address all of the safety concerns, if any, associated with its use. It is the responsibility of the user of this standard to establish appropriate safety and health practices and determine the applicability of regulatory limitations prior to use.* For specific hazards see Section 3.

1.7 *This international standard was developed in accordance with internationally recognized principles on standardization established in the Decision on Principles for the Development of International Standards, Guides and Recommendations issued by the World Trade Organization Technical Barriers to Trade (TBT) Committee.*

2. Referenced Documents

2.1 *ASTM Standards:*²

~~A167A666~~ Specification for ~~Stainless and Heat-Resisting Chromium-Nickel Steel Plate, Sheet, and Strip~~ Annealed or Cold-Worked Austenitic Stainless Steel Sheet, Strip, Plate, and Flat Bar (Withdrawn 2014)

D149 Test Method for Dielectric Breakdown Voltage and Dielectric Strength of Solid Electrical Insulating Materials at Commercial Power Frequencies

D257 Test Methods for DC Resistance or Conductance of Insulating Materials

D295 Test Methods for Varnished Cotton Fabrics Used for Electrical Insulation

~~D374D374/D374M~~ Test Methods for Thickness of Solid Electrical Insulation (Metric) ~~D0374_D0374M~~

D1711 Terminology Relating to Electrical Insulation

D3487 Specification for Mineral Insulating Oil Used in Electrical Apparatus

D5032 Practice for Maintaining Constant Relative Humidity by Means of Aqueous Glycerin Solutions

E691 Practice for Conducting an Interlaboratory Study to Determine the Precision of a Test Method

2.2 *IEC Standard:*

IEC 60454-3 Specification for Pressure-Sensitive Adhesive Tapes for Electrical Purposes³

3. Hazards

3.1 The following specific substances are flammable liquids. Do not use them in the vicinity of open flames or electrical contacts: *acetone* (see 50.1 and 94.1), *heptane* (see 50.1 and 94.1), and *toluene* (see 70.6). They must be stored in closed containers, and it is imperative to clean apparatus in a well-ventilated area.

3.2 As toluene is a toxic substance, use toluene only where adequate ventilation is provided and in such manner as to avoid any absorption through the skin (see 70.6).

3.3 **Warning**—*It is possible that lethal voltages will be present when conducting test methods which evaluate electrical properties. It is essential that the test apparatus, and all associated equipment electrically connected to it, be properly designed and installed for safe operation. Solidly ground all electrically conductive parts that any person might come in contact with during the test. Provide means for use, at the completion of any test, to ground any parts which: were at high voltage during the test; have the potential to acquire an induced charge during the test; or have the potential to retain a charge even after disconnection of the voltage source. Thoroughly instruct all operators in the proper way to conduct tests safely. When making high voltage tests, particularly in compressed gas or in oil, it is possible that the energy released at breakdown will be sufficient to result in fire, explosion, or rupture of the test chamber. Design test equipment, test chambers, and test specimens so as to minimize the possibility of such occurrences and to eliminate the possibility of personal injury.*

SAMPLING

4. Sample and Specimen Requirements

4.1 The producer and consumer shall agree upon the number of rolls selected. Unless otherwise specified a minimum of three rolls per lot shall be selected.

4.2 For sampling purposes, a lot consists of identifiable materials of the same type, manufactured in one production run and offered for delivery at the same time.

² For referenced ASTM standards, visit the ASTM website, www.astm.org, or contact ASTM Customer Service at service@astm.org. For *Annual Book of ASTM Standards* volume information, refer to the standard's Document Summary page on the ASTM website.

³ Available from American National Standards Institute (ANSI), 25 W. 43rd St., 4th Floor, New York, NY 10036, <http://www.ansi.org>. International Electrotechnical Commission, 446 Main St., Worcester, MA 01608, <http://www.iec.ch>.

4.3 All test methods in this standard are intended to produce a test value for a single roll. Any reference to averaging of measurements refers to the averaging of measurements on a single roll and not to the average of all sample rolls.

4.4 See **Table 1** for a summary of standard requirements for the number of test specimens to select from each sample roll, the number of test measurements to make per test specimen, and the value to be reported.

4.5 Include in every report the complete identification of the tape tested.

SPECIMEN PREPARATION

5. Test Specimen Preparation

5.1 Place any roll of tape to test on a freely revolving mandrel. Except for determination of length of tape in a roll, remove and discard a minimum of three layers before removing tape for preparation of test specimens.

5.2 Remove sufficient length of tape, at the rate of approximately 50 mm/s (2 in./s), to provide the specimens required for all tests. Cut the tape with a sharp razor blade or scissors, unless otherwise specified. Place the tape on a smooth clean surface, adhesive side up, or suspend it from one end in free air. Protect the adhesive surface from dust. Do not allow the adhesive surface to contact the operator's fingers or other foreign objects. Allow flexible specimens to relax for at least two minutes. From this tape material, prepare specimens as required in the individual test methods. See also **Table 1**.

5.3 Use test specimens that are the width of the tape as received, if possible. If it is necessary to prepare narrower specimens as prescribed in the test method, use extreme care since hand trimming has the potential to materially affect the test results. Two recommended procedures are (1) to slit the specimen with a sharp razor blade free of nicks while the specimen is held down with a pattern of the desired width, or (2) to slit with mounted parallel sharp razor blades free of nicks to the desired width.

CONDITIONING

6. Terminology

6.1 Definitions:

6.1.1 *conditioning, n*—the exposure of a material to the influence of a prescribed atmosphere for a stipulated period of time or until a stipulated relation is reached between material and atmosphere.

7. Significance and Use

7.1 The physical and electrical properties such as adhesion, elongation, breaking strength, and dielectric breakdown will vary with temperature and moisture content. Actual service results are influenced by these factors. In order that test methods yield consistent and reproducible results, control the temperature and moisture content of the sample or specimen.

TABLE 1 Testing and Reporting

Test	Section	Tests per Specimen ^A	Specimens per Roll ^A	Report ^B
Width	14, 19	3	1	avg
Thickness	26	3	1	avg
Length of tape in a roll	35	1	1	value
Breaking strength	44	1	3	avg
Elongation	44	1	3	avg
Adhesion strength	52	1	3	avg
Unwind force				
Fast rate of removal	64	1	1	value
Slow rate of removal	64	3	1	avg
Flagging				
Class 1 Tape	71	3	1	avg
Class 2 Tape	75	1	3	avg
Thermosetting properties	81	1	3	avg
Dielectric breakdown voltage	89	3	3	avg
Insulation resistance at high humidity	95	5	1	med
Effect of accelerated aging	102	3	2	avg
Flammability	108	1	3	avg
Bond strength after solvent immersion	114	1	3	avg
Oil resistance	121	1	4	avg
Puncture resistance	127	1	5	avg
Resistance to accelerated aging	129, 133	1	6	avg
Curling and twisting	140	1	3	avg

^A When referee testing is involved, use an average of 5 determinations wherever 1 or 3 are specified above.

^B Minimum and maximum values are also occasionally required when average values are reported.

8. Conditioning for Room Temperature Measurements

8.1 Condition all rolls of tape for a minimum of 24 h to a temperature of $23 \pm 5^\circ\text{C}$ ($73 \pm 9^\circ\text{F}$) before removing specimens for test.

8.2 Condition all test specimens for a period of 1 h in a controlled atmosphere at $23 \pm 5^\circ\text{C}$ ($73 \pm 9^\circ\text{F}$) and $50 \pm 10\%$ relative humidity prior to testing.

8.3 Unless otherwise specified, testing shall be conducted at $23 \pm 5^\circ\text{C}$ ($73 \pm 9^\circ\text{F}$) and $50 \pm 10\%$ relative humidity.

8.4 For referee testing purposes, subject all sample rolls to a controlled laboratory temperature of $23 \pm 1^\circ\text{C}$ ($73.4 \pm 1.8^\circ\text{F}$) for a minimum period of 24 h before removing specimens for test.

8.5 Unless otherwise specified, condition all referee test specimens for a period of 1 h in a controlled laboratory atmosphere at $23 \pm 1^\circ\text{C}$ ($73.4 \pm 1.8^\circ\text{F}$) and $50 \pm 2\%$ relative humidity.

8.6 Unless otherwise specified, referee testing shall be conducted at $23 \pm 1^\circ\text{C}$ ($73.4 \pm 1.8^\circ\text{F}$) and $50 \pm 2\%$ relative humidity.

9. Conditioning for Low Temperature Measurements

9.1 Elastomeric backings of Class 2 tapes have the potential to be subject to cold temperature tests. Condition elastomeric backings of Class 2 tapes for cold temperature tests by placing prepared specimens or rolls of tape in a cold room for at least 2 h at the desired temperature (example temperatures: 10°C , 0°C , -10°C , -18°C).

10. Apparatus for Low Temperature Conditioning

10.1 Cold room or cold chamber capable of maintaining the desired cold temperatures during testing.

WIDTH OF TAPE

Method A—Steel Ruler

11. Apparatus

11.1 A steel scale having divisions at 0.5 mm or $\frac{1}{64}$ -in. intervals.

12. Test Specimens

12.1 Select test specimens of approximately 450 mm (18-in.) lengths of tape taken from each sample roll in accordance with 5.2 and conditioned in accordance with Section 8.

13. Procedure

13.1 Place the test specimen, after conditioning, without tension or pressure, adhesive side down on a hard smooth surface. Measure the width perpendicular to the edge with the steel scale at three approximately equally-spaced points along the length.

14. Report

14.1 Report the average width in millimetres or inches, plus the maximum and minimum, if specified.

15. Precision and Bias

15.1 This test method has been in use for many years, but no statement of precision has been made and no activity is planned to develop such a statement.

15.2 This test method has no bias because the value for width is defined in terms of this test method.

Method B—Caliper

16. Apparatus

16.1 A pair of calipers with a scale length larger than width of the roll of tape, having divisions at 0.5-mm or $\frac{1}{64}$ -in. intervals.

17. Test Specimen

17.1 One roll of tape, conditioned in accordance with Section 8. Unless damaged, no outer layers need to be removed.

18. Procedure

18.1 The outer turns of the roll must have clean and sharp edges. Discard any damaged or crushed edges. After conditioning the roll of tape, place it on a table in a vertical position. Open the jaws of the calipers and slide them over the cut edges of the tape so that the scale shaft is parallel to the table. Close the caliper jaws slowly so as to just touch the sides of the tape roll. Be

careful not to crush the edges and keep the caliper jaws perpendicular to the edges of the tape. Measure the width perpendicular to the edges in mm (in.) to the nearest 0.5 mm ($\frac{1}{64}$ in.) at three approximately equally-spaced points along the circumference of the roll.

19. Report

19.1 Report the average width in millimetres or inches, plus the maximum and minimum, if specified.

20. Precision and Bias

20.1 This test method has been in use for many years, but no statement of precision has been made and no activity is planned to develop such a statement.

20.2 This test method has no bias because the value for width is defined in terms of this test method.

THICKNESS

21. Terminology

21.1 *Definitions of Terms Specific to This Standard:*

21.1.1 *thickness, n*—the perpendicular distance between the opposite surfaces of pressure-sensitive adhesive tape as determined in accordance with this test method.

22. Significance and Use

22.1 The thickness is of value in controlling uniformity and providing design data, as well as for use in determining physical and electrical properties.

23. Apparatus

23.1 *Thickness Gauge*—A dead weight thickness gauge as prescribed in Apparatus C of Test Methods [D374/D374M](#), with the following modifications:

23.1.1 *Presser Foot Diameter*—6 mm ($\frac{1}{4}$ in.).

23.1.2 *Anvil Diameter*—6 mm to 50 mm ($\frac{1}{4}$ to 2 in.).

23.1.3 A weighted presser foot so that the total pressure applied to a specimen is equal to 50 ± 5 kPa (7.6 ± 0.5 psi). Calibrate the gauge for the actual load exerted by the presser foot.

23.1.3.1 Any commercial instrument that satisfies 23.1.3, including a hand-held micrometer, is permissible for the thickness measurement.

24. Test Specimens

24.1 In accordance with 5.2 and Section 8, prepare and condition specimens of tape of a single thickness a minimum length of 450 mm (18 in.). Let flexible specimens relax for at least 2 min before testing.

25. Procedure

25.1 Place the test specimen upon the anvil of the gauge, smoothly, with adhesive side down, but without tension. Lower the presser foot onto the tape gradually to minimize any impact force, allowing it to rest upon the tape for 2 s, and then observe the reading to the nearest 0.0025 mm (0.0001 in.) of the thickness gauge scale. Make sure no air bubbles are trapped.

25.2 Take three measurements uniformly distributed over the surface of the test specimen.

26. Report

26.1 Report the following information:

26.1.1 The average thickness to the nearest 0.0025 mm (0.0001 in.) plus the maximum and minimum, if specified.

27. Precision and Bias

27.1 Data obtained from a round-robin investigation on several types of pressure-sensitive adhesive tape indicate that thickness measurements within a single laboratory can be expected to fall within ± 5 % of the mean value, and that measurements between laboratories can be expected to fall within ± 10 % of the overall mean value.⁴

27.2 A statement of bias is not applicable in view of the unavailability of a standard reference material for this property.

⁴ Supporting data have been filed at ASTM International Headquarters and may be obtained by requesting Research Report RR:D09-1008.

LENGTH OF TAPE IN A-ROLL

28. Terminology

28.1 Definitions of Terms Specific to This Standard:

28.1.1 length of tape in a roll, *n*—the number of linear metres or yards of tape wound into a roll as measured in accordance with these test methods.

29. Significance and Use

29.1 Measurement of the length of tape in a roll is necessary to ensure receiving correct quantities.

Method A—Balance Method

30. Apparatus

30.1 Balance—Two required, one capable of weighing to the nearest 0.1 g, the other capable of weighing to 1 mg.

30.2 Steel Rule—Capable of measuring to the nearest 2 mm (0.1 in.).

31. Test Specimen

31.1 A test specimen is a single thickness of pressure-sensitive adhesive tape approximately 1 m (3 ft) long removed from a full roll of tape as received from the manufacturer. Condition each specimen as described in Section 8.

32. Procedure

32.1 Determine the number of rolls to be tested for length in accordance with the schedule described in Section 4.

32.2 Remove the core from the roll. Weigh each roll to the nearest 0.1 g (Note 3). Remove a specimen of tape approximately 1 m (3 ft) long from the roll in accordance with the procedure described in Section 5, except DO NOT DISCARD the first three layers. After conditioning, measure the relaxed length of the specimen to the nearest 2 mm or 0.1 in. and weigh to the nearest mg.

NOTE 3—If it is desired to run additional tests on the tape in the roll, it is permissible to first weigh the roll with the core in place and then subtract the weight of the core after all test specimens are removed.

32.3 Calculate the metres per roll as follows:

$$\text{Metres per roll} = \frac{\text{weight of roll less core} \times \text{length of specimen, mm}}{\text{weight of specimen} \times 1000} \tag{1}$$

32.4 Calculate the yards per roll as follows:

$$\text{Yards per roll} = \frac{\text{weight of roll less core} \times \text{length of specimen, in.}}{\text{weight of specimen} \times 36} \tag{2}$$

Method B—Length Sensor Method

33. Apparatus

33.1 Length Sensor—A device to measure length by using a benchmarked rotating wheel which rolls, with low torque and contact pressure, against the circumference of the roll as it unwinds. The apparatus includes a spindle for mounting the tape, the length sensor mechanism, and a read-out and rotating wind-up roll that can be used to either manually or automatically unwind the roll of tape. See Fig. 1.

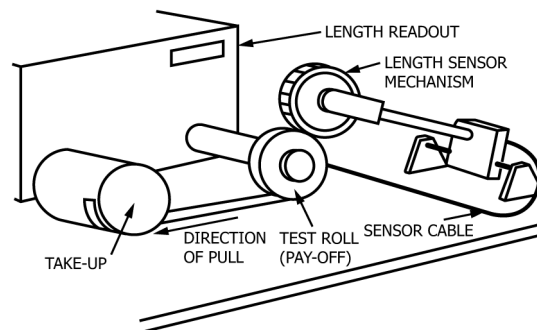

FIG. 1 Measuring Device for Determination of Length of Tape in a-Roll (Length Sensor Method)

34. Procedure

34.1 Determine the number of rolls to be tested for length in accordance with the schedule described in Section 4. Use only full rolls of tape. Do not remove any outer layer.

34.2 Mount the roll on the shaft adjacent to the sensor. Position the roll and length sensor so that the sensor is in contact with the circumference of the roll and the leading end of the roll is directly under the sensor. Zero the sensor and manually pull the leading edge of the tape and fix it to the wind-up roll. At the start of the unwinding, make sure that the length sensor maintains good contact with the roll and does not slip or bind. After unwinding is completed, take the reading of the length sensor.

35. Report

35.1 Report the following information:

35.1.1 The length of tape in each roll to the nearest 0.1 m (0.1 yd).

36. Precision and Bias

36.1 These test methods have been in use for many years, but no statement of precision has been made and no activity is planned to develop such a statement.

36.2 These test methods have no bias because the value for length is defined in terms of these test methods.

BREAKING STRENGTH AND ELONGATION

37. Terminology

37.1 *Definitions of Terms Specific to This Standard:*

37.1.1 *breaking strength of pressure-sensitive adhesive tape, n*—the force required, per unit width, to break the tape when tested under prescribed conditions.

37.1.2 *elongation of pressure-sensitive adhesive tape, n*—the increase in length at break when the tape is tested under prescribed conditions.

37.1.2.1 *Discussion*—

In the case of Class 1 tapes, it is feasible that the elongation may will include creep in the jaws which is often partially compensated for by “necking” of the specimen.

38. Significance and Use

38.1 *Breaking Strength*—Breaking strength of tape is important as a measurement of its uniformity, quality, and ability to withstand tensile stress in application and service.

38.2 *Elongation*—Elongation of tape is important as a measurement of its uniformity and quality, as well as a rough indication of its ability to conform to contours of uneven surfaces.

38.3 In the case of Class 2 tapes, testing at low temperature is necessary to ensure that the tape performs well at cold winter temperatures.

NOTE 4—It is possible that values obtained in dry ice chambers and walk-in cold rooms will not be equivalent.

39. Apparatus

39.1 *Testing Machine*—A testing machine of the constant-rate-of-extension (CRE) type is preferred. Equip the machine with a device for recording the tensile load and the amount of separation of the grips (~~Note 5~~) such that both of these measuring systems are accurate to $\pm 2\%$ of the breaking load or the amount of separation of the grips. The apparatus must be capable of providing smooth, uniform jaw movement during testing, and the rate adjustable in increments necessary to produce strain rates that are specified for the materials under test. Equip the machine with a load cell with a capacity such that the breaking load of the material under test falls between 10 and 90 % of the maximum capacity of the load cell.

~~NOTE 5—A high response speed in the recording system is desirable, particularly when relatively high strain rates are employed. The speed of pen response for recorders is supplied by manufacturers of this equipment. Take care to conduct tests at conditions such that response time (ability of recorder to follow actual load) will produce less than 2% error.~~

39.2 *Extension Indicator*—A suitable instrument for determining the distance between two fixed points located within the gauge length of the test specimen at any time during the test. It is desirable, but not essential, that this instrument automatically record this distance as a function of the load on the test specimen, or of the elapsed time for the start of the test, or both. If only the latter is obtained, also take load-time data. The extension indicator will usually have a separation of 25 mm (1 in.) between points and be a minimum of 25 mm (1 in.) from both the top and bottom jaws. If a suitable extension indicator is not available, elongation shall be calculated by jaw separation distance as described in Section 43.

39.3 *Holding Fixtures*—Use holding fixtures of any one of the following types, provided that the fixture does not cut the specimen or cause slippage:

39.3.1 *Air Jaws*—A device that can be fitted with various types of grips that will clamp onto a specimen through lever arms actuated by compressed air cylinders built into the body. The design provides a high gripping force with standard air pressure. Increased air pressure raises the gripping force to accommodate materials that are often difficult to hold in other types of grips.

39.3.2 *Drum Jaws*—Two smooth cylindrical metallic drums, 50 mm (2 in.) in diameter with a minimum length of ~~38 mm~~ 38 mm (1½ in.), suitably marked to aid in proper specimen alignment.

NOTE 5—While drum jaws are permissible, they are not preferred. The design of drum jaws makes it extremely difficult to identify accurately the gauge length between jaws.

39.3.3 *Manual Jaws*—A device that can be fitted with various types of grips that will clamp onto a specimen through a manually operated lever.

39.3.4 *Grips*—For manual jaws.

39.3.4.1 *Line Contact* grips have faces designed to concentrate the entire gripping force along a single line perpendicular to the direction of testing stress. This is usually done by combining one standard flat face with an opposing face from which protrudes a half-round.

39.3.4.2 *Flat Faced* grips have their surfaces finished in order to give the best clamping force on the material for test. The choice is determined largely by practical experience with the materials tested. It is acceptable for the faces to be smooth-ground, rubber-coated, or serrated. In general, the smooth-ground surface offers high gripping efficiency with most flat materials. The rubber-coated surface is of value with materials that tend to be weakened by pinching at the edge of the jaw face. The serrated surface is recommended for stronger materials that require the greatest gripping action.

It is acceptable to use double-coated tape to reinforce gripping, by applying a thin piece of tape on each side of the flat grips.

39.3.4.3 *Cold Chamber*—For cold temperatures testing, if a cold chamber is used for conditioning, it must be equipped with a slot suitable for inserting the tape.

39.3.4.4 *Gloves*—White cotton for handling very cold samples.

40. Conditioning

40.1 Condition rolls of tape or specimens according to Sections 6 – 10 for either room or low temperature testing.

41. Test Specimens

41.1 Select specimens in accordance with 5.2 and Section 8. Use specimens that are the width of the tape as received if possible. If it is necessary to trim the specimens due to the machine or jaw width limitations, take extreme care since hand trimming has the potential to materially affect the test results. See 5.3 for recommended procedures to slit narrower widths. Put benchmarks on the specimens, if needed.

42. Procedure

42.1 *Air Jaws or Manual Jaws*—Position the crosshead at the desired gauge length and insert the specimen in the grips. Tighten the movable grip first. If this process applies a preload on the specimen, do not change the balance adjustment to compensate for it. Adjust the initial length of the specimen between contact points to 100 mm (4 in.).

42.2 *Drum Jaws*—Hold the test specimen in place by placing approximately three quarters of a turn of the tape around each holding fixture with the adhesive side in contact with the drum. Place the tape in the center of the drums with the edges parallel to the scribed lines. Adjust the initial length of the specimen between contact points to 100 mm (4 in.).

42.3 Use a constant jaw speed of 300 ± 13 mm/min ($12 \pm \frac{1}{2}$ in./min), unless otherwise specified.

42.4 Discard breaks that occur at the jaws. Make a minimum of three acceptable determinations.

43. Calculation

43.1 Read the breaking strength directly from the recording chart or digital readout.

43.2 Read the percent elongation from the chart or digital readout or record the distance between benchmarks at the instant of break or rupture, and note the jaw separation or the distance between benchmarks at the instant of break or rupture, and calculate the percent elongation as follows:

$$\text{Elongation, \%} = [(D_2 - D_1)/D_1] \times 100 \quad (3)$$

where:

D_1 = original distance between jaws or benchmarks, and

D_2 = distance at instant of break or rupture between jaws or benchmarks.

44. Report

44.1 Report the following information:

44.1.1 Temperature conditions,

44.1.2 Average breaking strength expressed in newtons per 10 mm of width (N/10 mm) or in pounds-force per inch of width, plus the maximum and minimum, if specified, and

44.1.3 Average percent elongation, plus the maximum and minimum, if specified.

45. Precision and Bias

45.1 Data obtained from a round-robin investigation on several types of pressure-sensitive adhesive tape indicate that breaking-strength measurements within a single laboratory can be expected to fall within $\pm 15\%$ of the mean value, and elongation measurements to within $\pm 25\%$ of the mean value. Among different laboratories they can be expected to fall within $\pm 20\%$ and $\pm 30\%$, respectively, of the overall mean value.⁴

45.2 A statement of bias is not applicable in view of the unavailability of a standard reference material for these properties.

ADHESION STRENGTH TO STEEL AND BACKING

46. Terminology

46.1 *Definitions of Terms Specific to This Standard:*

46.1.1 *adhesion strength of pressure-sensitive adhesive tape, n*—the force necessary to remove the tape from a prescribed surface when measured in accordance with this test method.

47. Significance and Use

47.1 In many applications the use of a pressure-sensitive adhesive tape depends upon adhesion strength to give satisfactory performance. The adhesion property is also important in determining the uniformity of quality.

48. Apparatus

48.1 *Testing Machine*—A constant rate of extension (CRE) testing machine shall be used. The testing machine shall have two clamps with centers in the same plane, parallel with the direction of the motion of the stressing clamp, and so aligned that the clamps will hold the specimen entirely in the same plane. The instrument shall be calibrated to an accuracy of 1 % of full scale and the scale range of any test shall be such that the mean test level falls within 10 to 90 % of full scale. Equip the machine with a device that allows a head separation of a minimum of 250 mm (10 in.).

48.2 *Test Panel*⁵—A flat steel sheet having a bright annealed finish, 50 by 125 by 1.5 mm mm and no less than 1.1 mm thick (2 by 5 by in. and no less than 1/16 in.). Use in. thick) conforming to stainless steel Type 302 or 304 as prescribed in Specification ~~A167A666~~ with. The surface roughness height of $0.050 \pm 0.025 \mu\text{m}$ ($2.0 \pm 1.0 \mu\text{in.}$) arithmetic shall be $50 \pm 25 \text{ nm}$ ($2 \pm 1 \mu\text{in.}$) arithmetical average deviation from the mean line. Panels showing stains, discoloration or scratches are not acceptable.

48.3 *Rubber Covered Steel Roller*—A steel roller, Fig. 2, $80 \pm 2.5 \text{ mm}$ ($3.25 \pm 0.1 \text{ in.}$) in diameter and $45 \text{ mm} \pm 1 \text{ mm}$ (1.75

⁵ The sole source of supply of the test panels meeting these requirements known to the committee at this time is Chemsultants International, 9079 Tylor Blvd., Mentor OH 44060 or at www.chemsultants.com. If you are aware of alternative suppliers, please provide this information to ASTM International Headquarters. Your comments will receive careful consideration at a meeting of the responsible technical committee,¹ which you may attend.

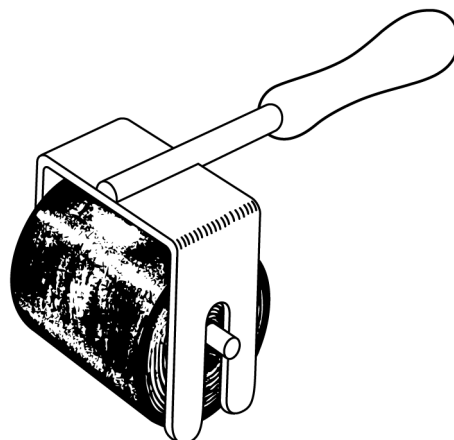

FIG. 2 Suggested Construction of Roller for Adhesion Strength Test

± 0.05 in.) wide, covered with rubber approximately ~~6 mm~~ 6 mm ($\frac{1}{4}$ in.) in thickness having a durometer hardness of 80 ± 5 Shore A. To apply pressure to the specimen, use a roller weighing 2000 ± 50 g (~~4.5~~ 4.5 ± 0.1 lb). Construct the roller so that the weight of the handle is not added to the weight of the roller during use. The operator has the option of using either a hand roller or a motor-driven roller.

49. Test Specimens

49.1 Use test specimens that are 250 mm (10 in.) long and no more than ~~25 mm~~ 25 mm (1 in.) wide. Remove each specimen from the roll in accordance with 5.2 so that neither surface in the test area contacts the operator's fingers nor any other foreign object.

49.2 Prepare three test specimens from each roll.

50. Procedure

50.1 *Adhesion to Steel Panel*—Prepare the polished surface of the steel panel by scrubbing it thoroughly, using a clean piece of surgical gauze saturated with any solvent capable of facilitating the removal of adhesive residue (**Warning**—see 3.1). Scrub the panel again using a clean piece of surgical gauze saturated with heptane or any other appropriate solvent (**Warning**—see 3.1). Discard the gauze after each cleaning step. After all traces of solvent evaporate, wipe the surface of the panel with a clean dry piece of surgical gauze.

NOTE 6—For referee testing, use new cleaned steel panels.

50.2 Remove the specimen from the roll. Let it relax for ~~about 2 min or more~~ at least 2 min. Apply it, adhesive side down, to the polished surface of the panel. Apply the specimen so that a 125-mm (5-in.) length extends beyond one end of the panel.

50.3 For tapes less than 25 mm (1 in.) wide, cut other strips from the same sample roll and apply parallel and adjacent to the test specimen to provide a total width of approximately ~~25 mm~~ 25 mm (1 in.) for rolling purposes only. Then, pass the roller, without application of additional pressure, over the backing of the tape lengthwise, once in each direction at the rate of approximately 300 mm/min (12 in./min). After the tape is on the panel for 20 min (50.3.1), double back the free end of the test specimen at an angle of 180° and peel 25 mm (1 in.) of the tape off the panel at the doubled end. Clamp this portion of the exposed panel in the lower jaw of the testing machine and place the free end of the tape in the upper jaw. Use a jaw travel rate of 300 mm/min (12 in./min). After the first 25 mm (1 in.) of tape is removed from the panel, read the specimen adhesion over the next 50 mm (2 in.). Do not take any readings during the removal of the last 25 mm (inch) of tape from the panel.

50.3.1 It is acceptable, in order to expedite testing, to measure the adhesion immediately after application of the tape to the panel, except for referee testing. This procedure results in slightly lower and more variable values.

50.4 Test double-sided tapes by removing the liner material and covering the adhesive surface not under test with soft tissue paper, such as facial tissue. <http://www.astm.org/catalog/standards/sist/c268c00d-40b1-48e1-a15a-9f82aaa25755/astm-d1000-17>

50.5 If the glass tapes have the potential to break on 180° pullback, reinforce them with another thickness of the same tape or a thinner paper-backed or plastic-backed tape. Report this modification.

50.6 *Adhesion to Backing*—Conduct the test of the adhesion of a tape to its own backing in a similar manner, except first affix a strip of the tape under test to each test panel with both ends wrapped around the ends of the panel. Use clean steel plates. Follow the procedure described in 50.1 – 50.3 except apply the test specimen to the tape backing rather than to the steel panel. Both test specimen and tape backing are to be used once.

51. Procedure for Low Temperatures Testing

51.1 For low temperature measurements, specimens prepared in Section 49 will be conditioned for 2 h according to Sections 9 and 10 before testing. Use white cotton gloves for handling very cold samples.

52. Report

52.1 Report the following information:

52.1.1 Testing temperatures,

52.1.2 Kind of test (to steel or to backing), and

52.1.3 Average of the three test values for each kind of test expressed in newtons per 10 mm of width (N/10 mm) or in ounces-force per inch of width, plus the maximum or minimum, if specified.

53. Precision and Bias

53.1 For adhesion to steel, in a round-robin investigation involving two laboratories and several types of pressure-sensitive adhesive tapes (plastic, cloth, and paper-backed tapes), data generated utilizing the procedures described in Practice E691 indicate