



Designation: D7043 – 17

Standard Test Method for Indicating Wear Characteristics of Non-Petroleum and Petroleum Hydraulic Fluids in a Constant Volume Vane Pump¹

This standard is issued under the fixed designation D7043; the number immediately following the designation indicates the year of original adoption or, in the case of revision, the year of last revision. A number in parentheses indicates the year of last reapproval. A superscript epsilon (ϵ) indicates an editorial change since the last revision or reapproval.

1. Scope*

1.1 This test method covers a constant volume vane pump test procedure operated at 1200 r/min and 13.8 MPa.

1.2 The values stated in SI units are to be regarded as standard. No other units of measurement are included in this standard.

1.2.1 *Exception*—There are no SI equivalents for the inch fasteners and inch O-rings that are used in the apparatus in this test method.

1.2.2 *Exception*—In some cases English pressure values are given in parentheses as a safety measure.

1.3 *This standard does not purport to address all of the safety concerns, if any, associated with its use. It is the responsibility of the user of this standard to establish appropriate safety and health practices and determine the applicability of regulatory limitations prior to use.*

1.4 *This international standard was developed in accordance with internationally recognized principles on standardization established in the Decision on Principles for the Development of International Standards, Guides and Recommendations issued by the World Trade Organization Technical Barriers to Trade (TBT) Committee.*

2. Referenced Documents

2.1 *ASTM Standards:*²

[D2882 Test Method for Indicating Wear Characteristics of Petroleum and Non-Petroleum Hydraulic Fluids in Constant Volume Vane Pump](#) (Withdrawn 2003)³

[D6300 Practice for Determination of Precision and Bias](#)

¹ This test method is under the jurisdiction of ASTM Committee D02 on Petroleum Products, Liquid Fuels, and Lubricants and is the direct responsibility of Subcommittee D02.N0 on Hydraulic Fluids.

Current edition approved July 1, 2017. Published July 2017. Originally approved in 2004. Last previous edition approved in 2012 as D7043 – 12. DOI: 10.1520/D7043-17.

² For referenced ASTM standards, visit the ASTM website, www.astm.org, or contact ASTM Customer Service at service@astm.org. For *Annual Book of ASTM Standards* volume information, refer to the standard's Document Summary page on the ASTM website.

³ The last approved version of this historical standard is referenced on www.astm.org.

[Data for Use in Test Methods for Petroleum Products and Lubricants](#)

[E177 Practice for Use of the Terms Precision and Bias in ASTM Test Methods](#)

[E691 Practice for Conducting an Interlaboratory Study to Determine the Precision of a Test Method](#)

3. Terminology

3.1 *Definitions of Terms Specific to This Standard:*

3.1.1 *flushing, v*—process of cleaning the test system before testing to prevent cross-contamination.

3.1.2 *torquing, v*—process of tightening the pump head bolts to achieve a uniform clamping force.

4. Summary of Test Method

4.1 An amount of 18.9 L \pm 0.5 L of a hydraulic fluid are circulated through a rotary vane pump system for 100 h at a pump speed of 1200 r/min \pm 60 r/min and a pump outlet pressure of 13.8 MPa \pm 0.3 MPa (2000 psi \pm 40 psi). Fluid temperature at the pump inlet is 66 °C \pm 3 °C for all water glycols, emulsions, and other water containing fluids and for petroleum and synthetic fluids of ISO Grade 46 or lighter. A temperature of 80 °C \pm 3 °C is used for all other synthetic and petroleum fluids.

4.2 The result obtained is the total mass loss from the cam ring and the twelve vanes during the test. Other reported values are initial flow rate and final flow rate.

4.3 The total quantity of test oil required for a run is 26.5 L.

5. Significance and Use

5.1 This test method is an indicator of the wear characteristics of non-petroleum and petroleum hydraulic fluids operating in a constant volume vane pump. Excessive wear in vane pumps could lead to malfunction of hydraulic systems in critical applications.

6. Apparatus

6.1 The basic system consists of the following (see Fig. 1):

6.1.1 *AC Motor*, 1200 r/min, or other suitable drive, with 11 kW (15 hp) as suggested minimum power requirement

*A Summary of Changes section appears at the end of this standard

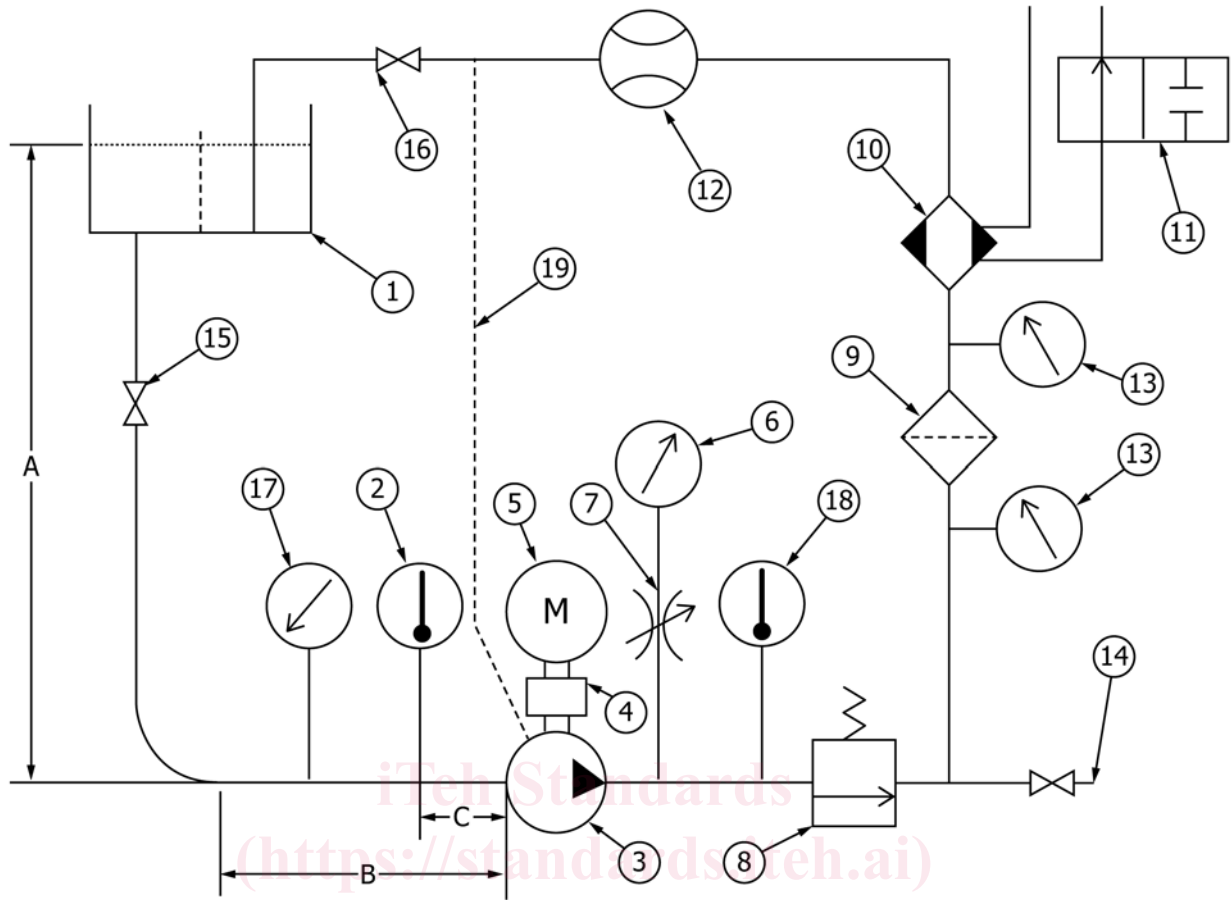

Item	Description	Required?
1.	Reservoir	
2.	Inlet temperature sensor	
3.	Pump	
4.	Flexible coupling	
5.	Motor	
6.	High pressure gauge	
7.	Snubber valve	
8.	Relief valve	
9.	Filter	
10.	Heat exchanger	
11.	Temperature control valve	
12.	Flow meter	
13.	Low pressure gauge	
14.	Fluid sampling port	
15.	Pump inlet valve	Not required
16.	Return line valve	Not required
17.	Inlet vacuum gauge	Not required
18.	Outlet temperature sensor	Not required
19.	Case drain for B1 pump	
A.	61 to 66 cm, vertical	Required
B.	15.2 cm, minimum horizontal	Required
C.	10.2 cm, maximum	Required

FIG. 1 System Schematic

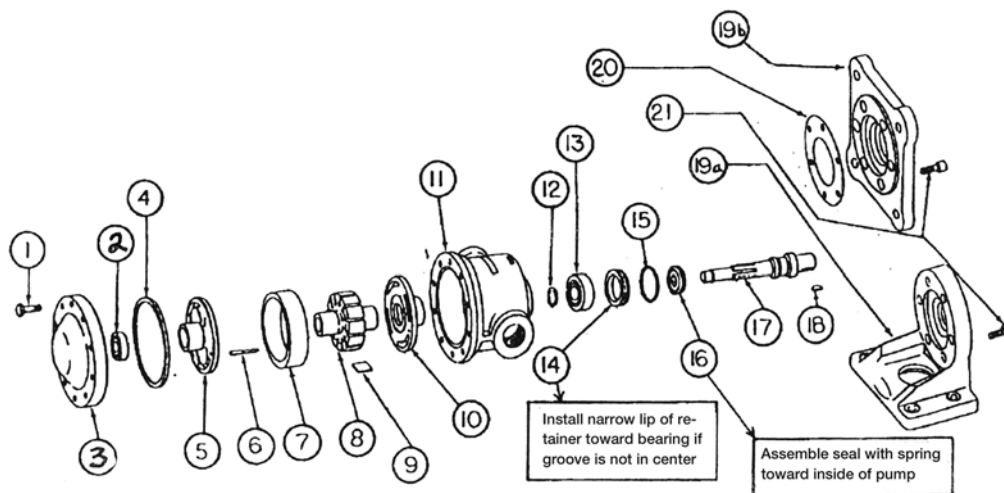

Description of Items			
Item Number	Name	Amount	Description
1	Head Bolt	8	3/8-16 x 1-1/4-in. hex head cap screw, Grade 8
2	Head Bearing	1	No. 6200, open type
3	Pump Head	1	Vickers 24064
4	Head Packing ^A	1	-235 square cut O-ring
5	Outer Bushing	1	Conestoga 2882-4E
6	Alignment Pin	1	Conestoga 2882-10
7	Cam Ring ^B	1	Conestoga 2882-5
8	Rotor ^B	1	Conestoga 2882-1C
9	Vane ^B	12	Conestoga 2882-V12 (12 piece kit)
10	Inner Bushing	1	Conestoga 2882-4C
11	Pump Body	1	Vickers 188235
12	Retaining Ring	1	20-mm steel retaining ring 3AM1-20
13	Shaft Bearing	1	#6204, open type
14	Seal Retainer	1	Vickers 185078
15	O-Ring ^A	1	-223 O-ring
16	Shaft Seal ^A	1	double lip with garter spring .875 x 1.500 x .312 rubber clad
17	Shaft	1	Conestoga 2882-2A
18	Key	1	Conestoga 2882-20A or Vickers 1612
19a	Foot Mount	1	Vickers 188234
19b	Flange Mount	1	Vickers 188233
20	Gasket	1	Conestoga 2882-27 or Vickers 2546 not used with Foot Mount (item 19a)
21	Screw	6	3/8-16 x 7/8 socket head cap screw

^A Specify compound.

^B Specify size.

FIG. 2 Pump Components

(Item 5, Fig. 1). The motor must have right hand rotation (counterclockwise rotation as viewed from the shaft end).

6.1.2 *Test Stand Base*, with appropriate, rigid mounting for the motor, pump, reservoir, and other components.

6.1.3 *Rotary Vane Pump*, replaceable cartridge type. A Vickers⁴ V104C or V105C or Conestoga USA B1 housing is used along with internal components from Conestoga USA, Inc.⁵ The assembly should produce 28.4 L/min flow at

1200 r/min with ISO Grade 32 fluid at 49 °C, at 6.9 MPa (Item 3, Fig. 1; Fig. 2; Fig. 3). (**Warning**—Eaton-Vickers test pump is rated at 6.9 MPa (1000 psi) but is being operated at 13.8 MPa (2000 psi). A protective shield around the pump is recommended.)

NOTE 1—This test method has been written for the use of Conestoga USA Inc. internals along with an Eaton-Vickers or Conestoga USA housing and head. If components from other manufacturers are used, refer to Test Method D2882 - 00 for preparation and selection guidelines.

6.1.3.1 The replaceable cartridge consists of the cam ring, the rotor, two bushings, a set of twelve vanes, and an alignment pin.

6.1.3.2 The individual cartridge parts are purchased separately. Conestoga USA, Inc. part numbers for these items are: cam ring No. 2882-5, alignment pin No. 2882-10, rotor No. 2882-1C, bronze bushings No. 2882-4C and 2882-4E, and vane kit (12 vanes) No. 2882-V12.

⁴ Previously available, this apparatus was made obsolete in 2000 by Vickers, which is part of Eaton Hydraulics Group USA 14615 Lone Oak Road Eden Prairie, MN 55344. If you are aware of alternative suppliers, please provide this information to ASTM International Headquarters. Your comments will receive careful consideration at a meeting of the responsible technical committee,¹ which you may attend.

⁵ The sole source of supply of the apparatus known to the committee at this time is Conestoga USA Inc., P.O. Box 3052, Pottstown, PA 19464. If you are aware of alternative suppliers, please provide this information to ASTM International Headquarters. Your comments will receive careful consideration at a meeting of the responsible technical committee,¹ which you may attend.

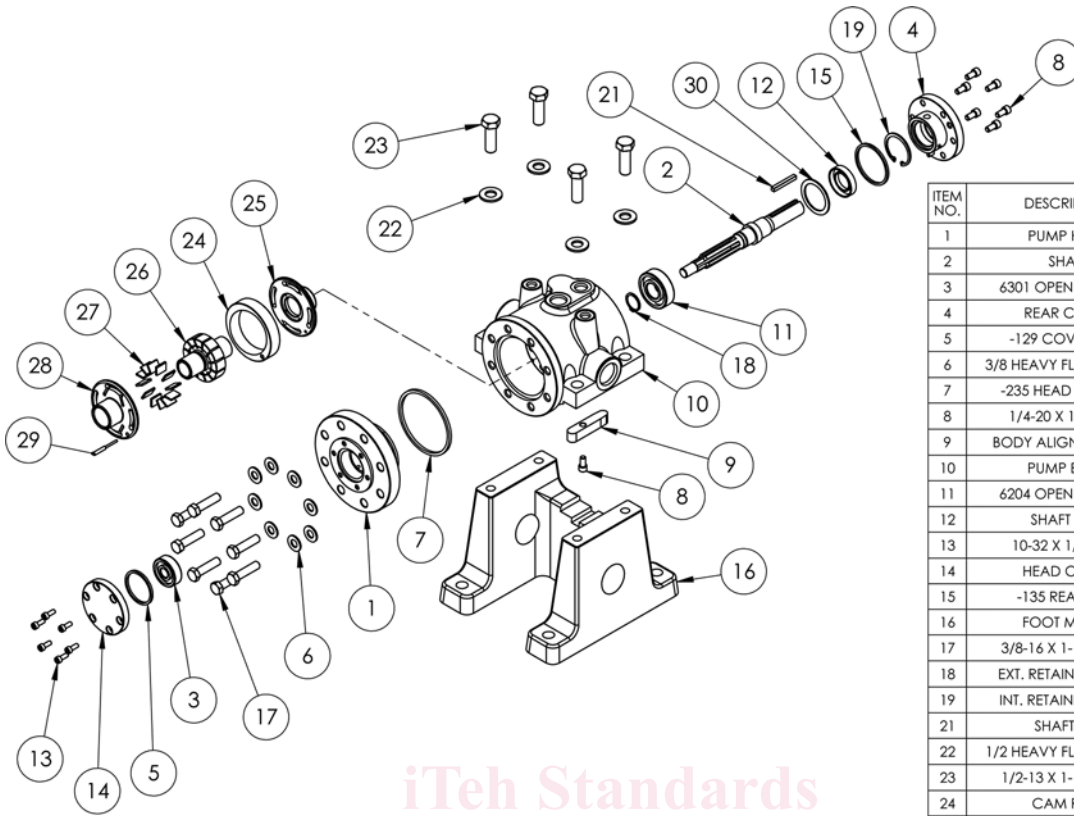

ITEM NO.	DESCRIPTION	PART NO.	QTY.
1	PUMP HEAD	B1-7	1
2	SHAFT	B1-2	1
3	6301 OPEN BEARING	B1-15	1
4	REAR COVER	B1-9	1
5	-129 COVER SEAL	B1-35	1
6	3/8 HEAVY FLAT WASHER	B1-42	8
7	-235 HEAD PACKING	2882-18	1
8	1/4-20 X 1/2 SHCS	B1-23	7
9	BODY ALIGNMENT KEY	B1-6C	1
10	PUMP BODY	B1-6	1
11	6204 OPEN BEARING	B1-4	1
12	SHAFT SEAL	2882-16	1
13	10-32 X 1/2 SHCS	B1-22	6
14	HEAD COVER	B1-8	1
15	-135 REAR SEAL	B1-36	1
16	FOOT MOUNT	B1-30	1
17	3/8-16 X 1-1/2 HHCS	B1-21	8
18	EXT. RETAINING RING	2882-24	1
19	INT. RETAINING RING	B1-37	1
21	SHAFT KEY	2882-20A	1
22	1/2 HEAVY FLAT WASHER	B1-30H	4
23	1/2-13 X 1-1/2 HHCS	B1-30G	4
24	CAM RING	2882-5	1
25	INNER BUSHING	2882-4C	1
26	ROTOR	2882-1C	1
27	VANE	2882-3	12
28	OUTER BUSHING	2882-4E	1
29	ALIGNMENT PIN	2882-10	1
30	W1819-020 WAVE SPRING	B1-25	1

iTech Standards
 (https://standards.itih.a
 Document Preview

FIG. 3 Conestoga USA, Inc., B1 Pump Assembly

ASTM D7043-17

<https://standards.itih.ai/catalog/standards/sist/e2e0c1f5-d530-405f-8958-b5c6831a88f1/astm-d7043-17>

6.1.3.3 There are to be no modifications to the pump housing such as plugging the drain hole in the pump body or drilling and tapping a hole in the head for an external drain.

6.1.4 Reservoir; (Item 1, Fig. 1).

6.1.4.1 The reservoir shall be equipped with a removable baffle and a close fitting lid, all of stainless steel construction. The reservoir can be square or rectangular (with a flat bottom) or cylindrical (with a spherical or cone shaped bottom) and must be designed so as to avoid air entrainment in the fluid.

NOTE 2—A suitable reservoir design is presented in Test Method D2882 - 00.

6.1.4.2 To promote deaeration and thermal mixing of the fluid, the baffle shall be designed so that returning fluid will follow an indirect path from the return port to the outlet port.

6.1.4.3 To avoid air entrainment, the reservoir shall be designed so that the return line enters well below the fluid level, fluid flow does not cascade over the baffle, and there will be a minimum of 15 cm of fluid depth above the pump inlet line.

6.1.4.4 Fluid ports may be added as required by the user for the installation of a low level switch, reservoir temperature sensor, bottom drain, and so forth.

6.1.4.5 If the reservoir is positioned so that the contents cannot be visually checked for aeration by removing the lid, a fluid-tight glass viewing port may be located in the side of the reservoir.

6.1.5 Outlet Pressure Control Valve, Eaton-Vickers pressure relief valve (CT-06-C/3.4 to 13.8 MPa) with either manual or remote control (Item 8, Fig. 1).⁶

6.1.6 Temperature Control Device, suitable for controlling coolant flow to the heat exchanger to maintain test fluid at the specified temperature (Item 11, Fig. 1).

6.1.7 Temperature Indicator; (Item 2, Fig. 1) shall have an accuracy of ±1 °C and shall have an appropriate sensor to monitor pump inlet temperature.

6.1.7.1 To prevent a flow restriction near the pump inlet port, the temperature probe shall have a diameter of not more than 6 mm.

6.1.7.2 The test fluid temperature shall be measured within 10.2 cm of the pump inlet (Dimension C, Fig. 1). The sensing probe shall be inserted into the midpoint of flow.

⁶ Request Vickers publication I-3369-S for the relief valve service data. See <http://hydraulics.eaton.com/products/vickers.html>.

NOTE 3—Some users have found the addition of a pump outlet temperature sensor to be a useful diagnostic tool. If used, it shall be suitable for 13.8 MPa duty and should be placed in the high pressure line between the pump and the relief valve (Item 18, Fig. 1).

6.1.8 *Heat Exchanger*, (Item 10, Fig. 1). The heat exchanger should be of adequate size and design to remove the excess heat from the test system when using the available coolant supply.

NOTE 4—It is suggested that a shell-and-tube-type heat exchanger, if used, should be connected in reverse (the hydraulic fluid is passed through the tubes and not around them) so that the interior of the heat exchanger can be effectively cleaned between tests.

6.1.9 *Pressure Indicator*, (Item 6, Fig. 1) to measure pump discharge pressure shall have an accuracy of at least ± 0.3 MPa at 13.8 MPa. The gauge shall be suitable for 13.8 MPa duty.

6.1.9.1 The pressure indicator should be snubbed (Item 7, Fig. 1) to prevent damage from pulsations or sudden fluctuations of system pressure.

6.1.10 *Filter Unit* (Item 9, Fig. 1), 3 μm (minimum Beta 3 ratio of 100) replaceable fiberglass element with housing. Two new filter elements are required for each test.

6.1.10.1 The filter housing shall be non-bypassing and shall be provided with dual pressure gauges (Item 13, Fig. 1) or another suitable indicator to monitor pressure across the filter to warn of impending collapse of the element.

6.1.10.2 If dual pressure gauges are used to monitor filter pressure, the rated collapse pressure of the filter element should be known. The collapse pressure should be within the range of the gage.

6.1.11 *Flow Measuring Device*, (Item 12, Fig. 1) with an accuracy of at least ± 0.4 L/min.

6.1.12 While not required, it is suggested that low-level, high-pressure, high-temperature, and low-flow safety switches be incorporated into the system.

6.1.13 A check should be made to ensure that the flush and test fluid are not incompatible with hoses, seals, or any other materials in the system.

NOTE 5—The use of galvanized iron, aluminum, zinc, and cadmium should be avoided because of their high potential for corrosion in the presence of many non-petroleum hydraulic fluids.

6.1.14 *Flexible Motor Coupling*, (Item 4, Fig. 1).

6.2 The various components of the test system shall be placed in the system as indicated in Fig. 1.

6.2.1 The test system shall be arranged and provided with necessary drain valves so that complete draining is possible with no fluid trap areas.

6.2.2 Good hydraulics piping practices should be used when constructing the test system to avoid air ingestment points and flow restrictions.

6.2.3 The pump should be mounted so that its internal surfaces can easily be inspected and cleaned, alignment can be checked, and the operator has comfortable access when torquing the head.

6.2.4 The reservoir shall be located above the pump so that the fluid level in the reservoir will be between 61 cm and 66 cm above the center line of the pump when the test system is fully charged with 19 L of test fluid (Dimension A, Fig. 1).

6.2.4.1 The reservoir should be mounted so that it can be cleaned and filled with ease and the contents may be readily inspected by removal of the reservoir lid.

6.2.5 The inlet line (from the reservoir to the pump intake) shall have an internal diameter of at least 25 mm and shall have a straight horizontal run of at least 15 cm to where it connects to the pump inlet port (Dimension B, Fig. 1). If a hose is used, it shall be rated for vacuum service. The B1 pump uses dual inlet hoses with an internal diameter of 22 mm.

NOTE 6—Some users have found the addition of a compound pressure gage near the pump inlet port to be a useful diagnostic tool (Item 17, Fig. 1). However, exercise care to ensure that any ports added to the inlet line do not become air ingestment points.

NOTE 7—The use of a solenoid valve, finger screen or other device which restricts pump inlet flow is discouraged. Inlet restrictions adversely affect pump performance.

NOTE 8—When tubing is used for the pump inlet line, some users prefer to use a radius bend instead of an elbow near the pump inlet. If used, the straight run described in 6.2.5 shall be measured between the end of the bend and the pump inlet port. For optimal flow properties with 25 mm tubing, a 100 mm (4 in.) bend radius is recommended.

6.2.6 The high pressure discharge line (from the pump to the pressure control valve) shall be rated for 14 MPa (2000 psi) duty and have a minimum internal diameter of 15 mm. The B1 pump uses dual discharge hoses with an internal diameter of 10.4 mm.

6.2.7 The fluid return line and fittings (from the pressure control valve to the filter, flow counter, heat exchanger, and reservoir) shall be rated for 3 MPa duty and have a minimum internal diameter of 15 mm.

NOTE 9—Some users find the addition of a shut off valve on the return line (Item 16, Fig. 1) to be a useful addition to the piping since it allows filter changes and other system maintenance to be performed without draining the reservoir.

6.2.7.1 (**Warning**—If a shut-off valve is installed in the fluid return line, the user shall take procedural steps to ensure that this valve has been opened before the pump is started. If the valve is not opened, low-pressure system components will rupture, possibly endangering personnel.)

NOTE 10—Some users find the addition of a valve on the pump inlet line (Item 15, Fig. 1) to be a useful addition to the piping since it allows filter changes and other system maintenance to be performed without draining the reservoir. A full flow type of valve with an orifice of at least 25 mm (1 in.) is recommended.

6.2.7.2 (**Warning**—If a shut-off valve is installed in the pump inlet line, the user shall take procedural steps to ensure that this valve has been opened before the pump is started. If the valve is not opened, the pump will cavitate.)

6.2.8 The case drain hose for the B1 pump (Item 19, Fig. 1) shall be rated for 3 MPa duty and have a minimum internal diameter of 8 mm. The B1 case drain must connect to the return line so that the drain flow is unrestricted when the pump is in operation.

7. Reagents and Materials

7.1 **Warning**—Use adequate safety provisions with all solvents.

7.2 *Aliphatic Naphtha, Stoddard Solvent*, or equivalent is satisfactory. (**Warning**—Combustible. Vapor harmful.)

7.3 *Precipitation Naphtha* (**Warning**—Extremely flammable. Harmful if inhaled. Vapors can cause flash fire.)

7.4 *Isopropanol* (**Warning**—flammable.).

7.5 **Warning**—In instances when the solvents listed in Section 7 are not effective, alternative solvents may be used. It is the responsibility of the user to determine the suitability of alternative solvents and any hazards associated with their use.

8. Test Stand Maintenance

8.1 Sensors and shut-off switches should be checked periodically for proper calibration and operation in accordance with good engineering practice as determined by the user.

8.2 It is recommended that the pump shaft (Item 17, Fig. 2; Item 2, Fig. 3), seals (Items 4, 15, 16, Fig. 2; Items 5, 7, 12, 15, Fig. 3), and bearings (Items 2, 13, Fig. 2; Items 3, 11, Fig. 3) be replaced after every five runs (or sooner if high weight loss, vibration, cavitation, or visual deterioration is encountered).

8.2.1 A variety of seal compounds is available for the pump. It is the responsibility of the user to determine the best seal composition to use with any given fluid. If possible, check the cure date of the seal.

8.3 Inspect the pump body and head.

8.3.1 Visually examine the pump head and the interior of the pump body (Items 3 and 11, Fig. 2; Items 1, 10, Fig. 3). Replace if evidence of deterioration is observed.

8.3.2 When the pump has been disassembled for seal and bearing replacement, carefully inspect the faces of the pump body and head which seal against the bushing faces (Surfaces A and B, Fig. 4) for high spots, warped condition, or other damage which may interfere with a good fluid seal. Discard any unsuitable components.

8.3.3 Check that the Eaton-Vickers head bearing (Item 2, Fig. 2) is a press fit into the head. If it is loose, discard the head. The B1 head bearing (Item 3, Fig. 3) should be a close slip fit to the head.

8.3.4 Check that the shaft bearing (Item 13, Fig. 2; Item 11, Fig. 3) makes a close slip fit into the body. If it is loose, discard the body.

8.3.5 Check that the bore for the cartridge (Diameter E, Fig. 4) is not greater than 76.23 mm.

8.3.5.1 If the bore is oversized, the ring may crack when the pump is pressurized.

8.3.5.2 If the bore is oversized, a piece of 0.025 mm shim stock trimmed to 20 mm by 235 mm can be wrapped around the ring to pack out the excess clearance. Installation of the shim requires that the cartridge assembly be made in the pump housing and that the housing bore and ring outside diameter are clean and dry.

8.3.6 Check that the pump body ports align properly with the bushing ports, with no overlapping, which might restrict fluid flow.

NOTE 11—In some cases in which operational problems continue without apparent cause, a change of pump body or head, or both, has been known to alleviate the problem.

8.4 Inspect the shaft (Item 17, Fig. 2; Item 2, Fig. 3; Fig. 5).

8.4.1 Check that the splines of a new shaft are smoothly cut, have consistent width from the outer diameter to the root, and

are parallel with the axis of the shaft. Avoid reusing shafts if the rotor has worn deep marks in the splines (Items 1, 2, 3, and 4, Fig. 5).

8.4.2 Check new shafts and used shafts that have been subjected to pump failure or overheating for bending, twisting, or damage to the key seat or splines (Items 5 and 7, Fig. 5).

8.4.3 Check the surface where the shaft seal rides for conditions that may cause the seal to leak (Item 6, Fig. 5).

8.5 Check alignment of the pump and motor shafts. Maximum values of 0.08-mm parallel misalignment and 0.3° angular misalignment are suggested limits.

8.5.1 Alignment checks should be made with a torqued cartridge in place.

8.5.2 Using a test indicator, inspect the shaft for a bent condition by rotating it by hand with the motor coupling removed (Item 7, Fig. 5).

8.5.3 Precision ground coupling halves that have identical outside diameters and run true to the shaft with which they are used (pump or motor) will permit the use of a straight edge and feeler gages to achieve close alignment of the pump and motor shafts.

8.6 Periodically clean the eight tapped holes that receive the pump head bolts and the threads of the head bolts themselves (Item 1, Fig. 2; Item 17, Fig. 3). The threads may be coated with a light oil to prevent corrosion. To ensure even torquing of the cartridge, housings or head bolts with damaged threads should be discarded.

8.7 Periodic disassembly of the relief valve (Item 8, Fig. 1) for cleaning and inspection is recommended.

9. Sampling

9.1 The sample of fluid shall be thoroughly representative of the material in question, and the portion used for the test shall be thoroughly representative of the sample itself.

10. Flushing

10.1 Proper cleaning and flushing of the entire system is extremely important to prevent cross-contamination of test fluids.

10.2 Flushing procedure for petroleum and synthetic fluids:

NOTE 12—This flushing sequence is not adequate when changing fluid types such as from glycol to phosphate ester, oil to glycol, and so forth (see 7.5).

10.2.1 Drain all old fluid from the system, remove used test cartridge (if present), remove, and discard old filter. Wipe out pump and filter housings and the reservoir and baffle.

10.2.2 Install a flush cartridge (any good, previously used cartridge) and a new filter.

10.2.3 Close all drain valves and torque the pump head. Open the pump inlet and return line valves if used (see Notes 9 and 10).

10.2.4 Charge the system with 7.6 L of flushing fluid. For petroleum and synthetic fluids use either Stoddard solvent (**Warning**—see 7.2) or base stock depending on the similarity of the old and new test fluids.

NOTE 13—One flush of this petroleum solvent is usually sufficient to