



Designation: **C1202—12 C1202 – 17**

Standard Test Method for Electrical Indication of Concrete's Ability to Resist Chloride Ion Penetration¹

This standard is issued under the fixed designation C1202; the number immediately following the designation indicates the year of original adoption or, in the case of revision, the year of last revision. A number in parentheses indicates the year of last reapproval. A superscript epsilon (ϵ) indicates an editorial change since the last revision or reapproval.

1. Scope*

1.1 This test method covers the determination of the electrical conductance of concrete to provide a rapid indication of its resistance to the penetration of chloride ions. This test method is applicable to types of concrete where correlations have been established between this test procedure and long-term chloride ponding procedures such as those described in AASHTO T 259. Examples of such correlations are discussed in Refs **1-5**.²

1.2 The values stated in SI units are to be regarded as standard. No other units of measurement are included in this standard.

1.3 The text of this standard references notes and footnotes which provide explanatory material. These notes and footnotes (excluding those in tables and figures) shall not be considered as requirements of the standard.

1.4 *This standard does not purport to address all of the safety concerns, if any, associated with its use. It is the responsibility of the user of this standard to establish appropriate safety and health practices and determine the applicability of regulatory limitations prior to use.*

1.5 *This international standard was developed in accordance with internationally recognized principles on standardization established in the Decision on Principles for the Development of International Standards, Guides and Recommendations issued by the World Trade Organization Technical Barriers to Trade (TBT) Committee.*

2. Referenced Documents

2.1 *ASTM Standards:*³

C31/C31M Practice for Making and Curing Concrete Test Specimens in the Field

C42/C42M Test Method for Obtaining and Testing Drilled Cores and Sawed Beams of Concrete

C192/C192M Practice for Making and Curing Concrete Test Specimens in the Laboratory

C670 Practice for Preparing Precision and Bias Statements for Test Methods for Construction Materials

2.2 *AASHTO Standard:*

T 259 Method of Test for Resistance of Concrete to Chloride Ion Penetration⁴

3. Summary of Test Method

3.1 This test method consists of monitoring the amount of electrical current passed through 50-mm thick slices of 100-mm nominal diameter cores or cylinders during a 6-h period. A potential difference of 60 V dc is maintained across the ends of the specimen, one of which is immersed in a sodium chloride solution, the other in a sodium hydroxide solution. The total charge passed, in coulombs, has been found to be related to the resistance of the specimen to chloride ion penetration.

4. Significance and Use

4.1 This test method covers the laboratory evaluation of the electrical conductance of concrete samples to provide a rapid indication of their resistance to chloride ion penetration. In most cases the electrical conductance results have shown good correlation with chloride ponding tests, such as AASHTO T259, on companion slabs cast from the same concrete mixtures (Refs **1-5**).

¹ This test method is under the jurisdiction of ASTM Committee **C09** on Concrete and Concrete Aggregates and is the direct responsibility of Subcommittee **C09.66** on Concrete's Resistance to Fluid Penetration.

Current edition approved Feb. 1, 2012; June 15, 2017. Published March 2012; July 2017. Originally approved in 1991. Last previous edition approved in 2010 as C1202 – 10:12. DOI: 10.1520/C1202-12; 10.1520/C1202-17.

² The boldface numbers in parentheses refer to the list of references at the end of this standard.

³ For referenced ASTM standards, visit the ASTM website, www.astm.org, or contact ASTM Customer Service at service@astm.org. For *Annual Book of ASTM Standards* volume information, refer to the standard's Document Summary page on the ASTM website.

⁴ Methods of Sampling and Testing, 1986, American Association of State Highway and Transportation Officials, 444 N. Capitol St., NW, Washington, DC 20001.

*A Summary of Changes section appears at the end of this standard

4.2 This test method is suitable for evaluation of materials and material proportions for design purposes and research and development.

4.3 Sample age has significant effects on the test results, depending on the type of concrete and the curing procedure. Most concretes, if properly cured, become progressively and significantly less permeable with time.

4.4 This test method was developed originally for evaluations of alternative materials, but in practice its use has evolved to applications such as quality control and acceptance testing. Factors such as ingredient materials used in concrete mixtures and the method and duration of curing test specimens affect the results of this test (See **Note 1**). When this method is used for mixture qualification and acceptance testing, it is imperative that the curing procedures and the age at time of testing be clearly specified.

NOTE 1—When using this test for determining acceptability of concrete mixtures, statistically-based criteria and test age for prequalification, or for acceptance based on jobsite samples, should be stated in project specifications. Acceptance criteria for this test should consider the sources of variability affecting the results and ensure balanced risk between supplier and purchaser. The anticipated exposure conditions and time before a structure will be put into service should be considered. One approach to establishing criteria is discussed in Ref **6**.

4.5 **Table X1.1** in **Appendix X1** provides a qualitative relationship between the results of this test and the chloride ion penetrability of concrete.

4.6 Care should be taken in interpreting results of this test when it is used on surface-treated concretes, for example, concretes treated with penetrating sealers. The results from this test on some such concretes indicate low resistance to chloride ion penetration, while 90-day chloride ponding tests on companion slabs show a higher resistance.

4.7 The details of the test method apply to 100-mm nominal diameter specimens. This includes specimens with actual diameters ranging from 95 to 100 mm. Other specimen diameters may be tested with appropriate changes in the applied voltage cell design (see **7.5** and **Fig. 1**).

4.7.1 For specimen diameters other than 95 mm, the test result value for total charge passed must be adjusted following the procedure in **11.2**. For specimens with diameters less than 95 mm, particular care must be taken in coating and mounting the specimens to ensure that the conductive solutions are able to contact the entire end areas during the test.

5. Interferences

5.1 This test method can produce misleading results when calcium nitrite has been admixed into a concrete. The results from this test on some such concretes indicate higher coulomb values, that is, lower resistance to chloride ion penetration, than from tests on identical concrete mixtures (controls) without calcium nitrite. However, long-term chloride ponding tests indicate the concretes with calcium nitrite were at least as resistant to chloride ion penetration as the control mixtures.

NOTE 2—Other admixtures might affect results of this test similarly. Long term ponding tests are recommended if an admixture effect is suspected.

5.2 Since the test results are a function of the electrical resistance of the specimen, the presence of reinforcing steel or other embedded electrically conductive materials may have a significant effect. The test is not valid for specimens containing reinforcing steel positioned longitudinally, that is, providing a continuous electrical path between the two ends of the specimen.

6. Apparatus

6.1 *Vacuum Saturation Apparatus* (see **Fig. 2** for example):

6.1.1 *Separatory Funnel*, or other sealable, bottom-draining container with a minimum capacity of 500 mL.

6.1.2 *Beaker (1000 mL or larger) or other container*—Capable of holding concrete specimen(s) and water and of fitting into vacuum desiccator (see **6.1.3**).

6.1.3 *Vacuum Desiccator*—~~250-mm inside diameter or larger.~~ The volume of desiccator shall be large enough to maintain sample immersion throughout the saturation process. Desiccator must allow two hose connections through a rubber stopper and sleeve or through a rubber stopper only. Each connection must be equipped with a stopcock.

6.1.4 *Vacuum Pump or Aspirator*—Capable of maintaining a pressure of less than 50 mm Hg (6650 Pa) in desiccator.

NOTE 3—Since vacuum will be drawn over water, a vacuum pump should be protected with a water trap, or pump oil should be changed after each operation.

6.1.5 *Vacuum Gage or Manometer*—Accurate to ± 5 mm Hg (± 665 Pa) over range 0–100 mm Hg (0–13300 Pa) pressure.

6.2 *Coating Apparatus and Materials*:

6.2.1 *Coating*—Rapid setting, electrically nonconductive, capable of sealing side surface of concrete cores.

6.2.2 *Balance or Scale, Paper Cups, Wooden Spatulas, and Disposable Brushes*—For mixing and applying coating.

6.3 *Specimen Sizing Equipment* (not required if samples are cast to final specimen size).

6.3.1 *Movable Bed Water-Cooled Diamond Saw or Silicon Carbide Saw*.

7. Reagents, Materials, and Test Cell

7.1 *Specimen-Cell Sealant*—Capable of sealing concrete to poly (methyl methacrylate), for example, Plexiglas, against water and dilute sodium hydroxide and sodium chloride solutions at temperatures up to 90 °C; examples include RTV silicone rubbers, silicone rubber caulking, other synthetic rubber sealants, silicone greases, and rubber gaskets.

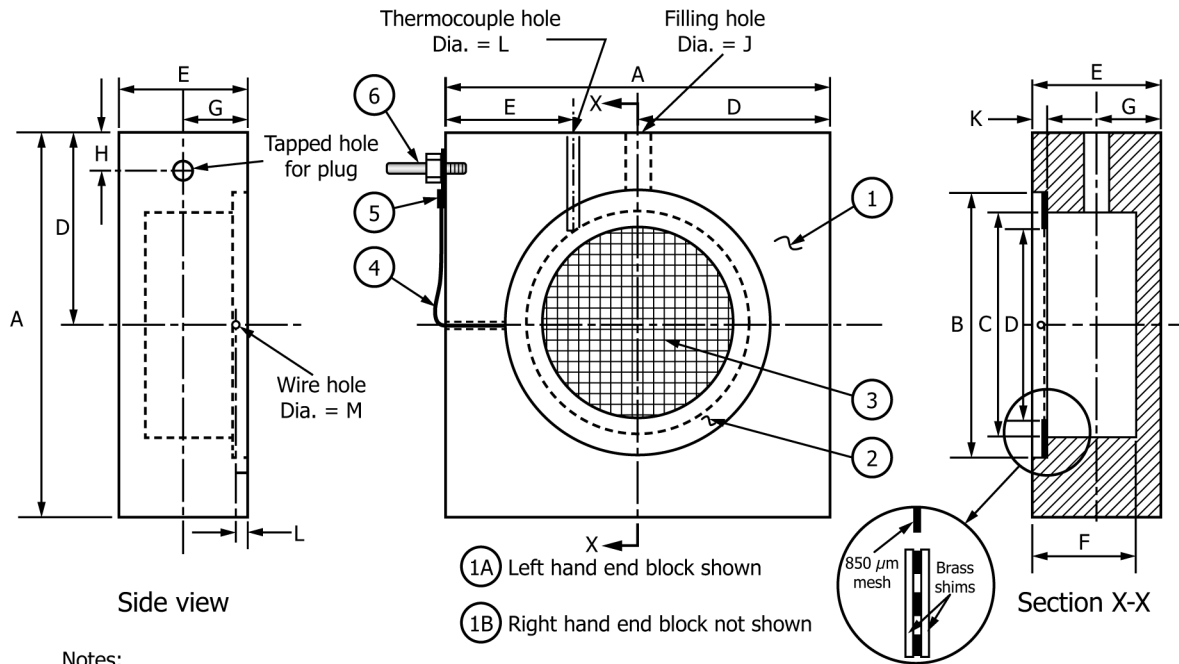

Notes:
 Seal wire in hole with silicone rubber
 Solder screen between shims
 Solder wire to shim

Dimensions, mm

A	B	C	D	E	F	G	H	J	K	L	M
150	105	89	75	50	41	25	15	10	6	5	2.5

Parts List

Item No.	Quantity	Description	Specification
1A 1B	1 1	Cell block end	Poly (methyl methacrylate)
2	4	Brass shim	0.5 mm thick
3	2	Brass screen	850 μ m (No. 20) mesh
4	2	Solid copper wire	2 mm (14 gauge) nylon cladding
5	2	Ring terminal	For 2 mm (14 gauge) wire
6	2	Banana plug	6.4 mm with threaded stud

FIG. 1 Applied Voltage Cell (Construction Drawing)

7.2 Sodium Chloride Solution—3.0 % by mass (reagent grade) in distilled water.

7.3 Sodium Hydroxide Solution—0.3 N (reagent grade) in distilled water.

7.3.1 **Warning**—Before using NaOH, review: (1) the safety precautions for using NaOH; (2) first aid for burns; and (3) the emergency response to spills, as described in the manufacturer’s Material Safety Data Sheet or other reliable safety literature. NaOH can cause very severe burns and injury to unprotected skin and eyes. Suitable personal protective equipment should always be used. These should include full-face shields, rubber aprons, and gloves impervious to NaOH. Gloves should be checked periodically for pin holes.

7.4 Filter Papers—No. 2, 90-mm diameter (not required if rubber gasket is used for sealant (see 7.1) or if sealant can be applied without overflowing from shim onto mesh).

7.5 Applied Voltage Cell (see Fig. 1 and Fig. 3)—Two symmetric poly (methyl methacrylate) chambers, each containing electrically conductive mesh and external connectors. One design in common use is shown in Fig. 1 and Fig. 3. However, other designs are acceptable, provided that overall dimensions (including dimensions of the fluid reservoir) are the same as shown in Fig. 1 and width of the screen and shims are as shown.

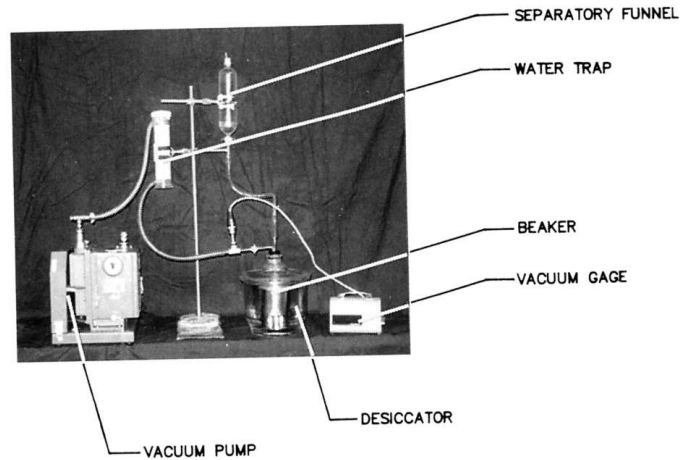

FIG. 2 Vacuum Saturation Apparatus

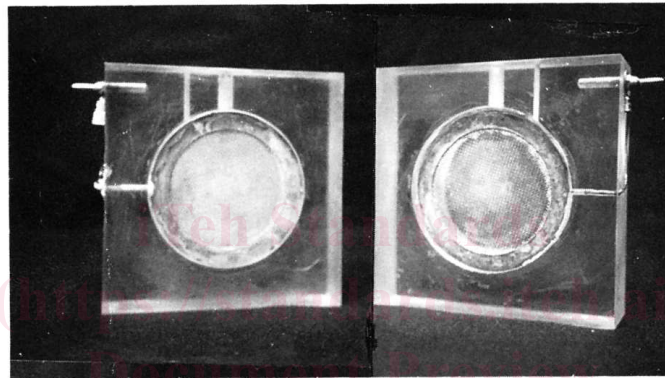

FIG. 3 Applied Voltage Cell-Face View

7.6 Temperature Measuring Device (optional)—0 to 120°C range.

7.7 Voltage Application and Data Readout Apparatus—Capable of holding 60 ± 0.1 V dc across applied voltage cell over entire range of currents and of displaying voltage accurate to ± 0.1 V and current to ± 1 mA. Apparatus listed in 7.7.1 – 7.7.5 is a possible system meeting this requirement.

7.7.1 Voltmeter—Digital (DVM), 3 digit, minimum 0–99.9 V range, rated accuracy ± 0.1 %.

7.7.2 Voltmeter—Digital (DVM), $4\frac{1}{2}$ digit, 0–200 mV range, rated accuracy ± 0.1 %.

7.7.3 Shunt Resistor—100 mV, 10A rating, tolerance ± 0.1 %. Alternatively, a 0.01 Ω resistor, tolerance ± 0.1 %, may be used, but care must be taken to establish very low resistance connections.

7.7.4 Constant Voltage Power Supply—0–80 V dc, 0–2 A, capable of holding voltage constant at 60 ± 0.1 V over entire range of currents.

7.7.5 Cable—Two conductor, AWG No. 14 (1.6 mm), insulated, 600 V.

8. Test Specimens

8.1 Sample preparation and selection depends on the purpose of the test. For evaluation of materials or their proportions, samples may be (a) cores from test slabs or from large diameter cylinders or (b) 100-mm diameter cast cylinders. For evaluation of structures, samples shall be cores from the structure. Coring shall be done with a drilling rig equipped with a 100-mm diameter diamond-dressed core bit. Select and core samples following procedures in Test Method C42/C42M. Cylinders cast in the laboratory shall be prepared following procedures in Practice C192/C192M.

NOTE 4—The maximum allowable aggregate size has not been established for this test. Users have indicated that test repeatability is satisfactory on specimens from the same concrete batch for aggregates up to 25.0 mm nominal maximum size.

8.2 When results of this test method are used for evaluation of materials or mixture proportions based on cast specimens for purposes of quality control, mixture submittals, or acceptance of concrete, prepare at least two 100-mm diameter cylindrical specimens in accordance with Practice C192/C192M for concrete mixtures prepared in the laboratory or Practice C31/C31M from samples of fresh concrete obtained in the field. Moist cure specimens in accordance with 8.2.1 for concrete mixtures containing only portland cement. For concrete mixtures containing supplementary cementitious materials use extended moist curing in

accordance with 8.2.2 (see Note 5) unless the accelerated moist curing method of 8.2.3 is specified (see Note 6). Alternatives to these curing methods and durations are permitted when specified. Use the same method and duration of curing for preparing mixture submittals, for subsequent acceptance testing, and for comparing two or more mixtures.

8.2.1 *Moist Curing*—Cure test specimens for 28 days in accordance with Practice C192/C192M or in accordance with the standard curing procedure of Practice C31/C31M for specimens prepared in the field.

8.2.2 *Extended Moist Curing*—Cure test specimens for 56 days in accordance with Practice C192/C192M for specimens prepared in the laboratory or in accordance with the standard curing procedure of Practice C31/C31M for specimens prepared in the field.

8.2.3 *Accelerated Moist Curing*—Provide 7 days of moist curing in accordance with Practice C192/C192M for specimens prepared in the laboratory or in accordance with the standard curing procedure of Practice C31/C31M for specimens prepared in the field. After 7 days of moist curing, immerse the specimens for 21 days in lime-saturated water at 38.0 ± 2.0 °C.

NOTE 5—The 56-day moist curing period is to allow for some supplementary cementitious materials to develop potential properties because of their slower rate of hydration. Concrete containing supplementary cementitious materials may continue to show reductions in results of this test beyond 56 days, and in some cases, it may be appropriate to test at later ages, such as 3 months.

NOTE 6—The accelerated moist curing procedure has been found useful in providing an earlier indication of potential property development with slower hydrating supplementary cementitious materials (7). Because the two different curing methods may not provide the same results, the specifier of the test may require a correlation between results for extended moist cured and accelerated moist cured specimens and establish appropriate acceptance criteria when the accelerated moist curing procedure is used or permitted. Comparisons between results of moist cured specimens and field performance of concrete are documented in (8).

8.3 Transport the cores to the laboratory in sealed (tied) plastic bags. If specimens must be shipped, they should be packed so as to be properly protected from freezing and from damage in transit or storage.

8.4 Using the water-cooled diamond saw or silicon carbide saw, cut a 50 ± 3 mm slice from the top of the core or cylinder, with the cut parallel to the top of the core. This slice will be the test specimen. Use a belt sander to remove any burrs on the end of the specimen.

8.5 Special processing is necessary for core samples where the surface has been modified, for example, by texturing or by applying curing compounds, sealers, or other surface treatments, and where the intent of the test is not to include the effect of the modifications. In those cases, the modified portion of the core shall be removed and the adjacent 50 ± 3 mm slice shall be used for the test.

9. Conditioning

9.1 Vigorously boil a litre or more of tapwater in a large sealable container. Remove container from heat, cap tightly, and allow water to cool to ambient temperature.

9.2 Allow specimen prepared in Section 8 to surface dry in air for at least 1 h. Prepare approximately 10 g of rapid setting coating and brush onto the side surface of specimen. Place the sample on a suitable support while coating to ensure complete coating of sides. Allow coating to cure according to the manufacturer's instructions.

9.3 The coating should be allowed to cure until it is no longer sticky to the touch. Fill any apparent holes in the coating and allow additional curing time, as necessary. Place specimen in beaker or other container (see 6.1.2), then place container in vacuum desiccator. Alternatively, place specimen directly in vacuum desiccator. Both end faces of specimen must be exposed. Seal desiccator and start vacuum pump or aspirator. Pressure should decrease to less than 50 mm Hg (6650 Pa) within a few minutes. Maintain vacuum for 3 h.

9.4 Fill separatory funnel or other container (see 6.1.1) with the de-aerated water prepared in 9.1. With vacuum pump still running, open water stopcock and drain sufficient water into beaker or container to cover specimen (do not allow air to enter desiccator through this stopcock).

9.5 Close water stopcock and allow vacuum pump to run for one additional hour.

9.6 Close vacuum line stopcock, then turn off pump. (Change pump oil if a water trap is not being used.) Turn vacuum line stopcock to allow air to re-enter desiccator.

9.7 Soak specimen under water (the water used in steps 9.4 – 9.6) in the beaker for 18 ± 2 h.

10. Procedure

10.1 Remove specimen from water, blot off excess water, and transfer specimen to a sealed can or other container which will maintain the specimen in 95 % or higher relative humidity.

10.2 Specimen mounting (all sealants other than rubber gaskets; use 10.2.2 or 10.2.3, as appropriate):

10.2.1 If using two-part specimen-cell sealant, prepare approximately 20 to 40 g.

10.2.2 *Low Viscosity Specimen-Cell Sealant*—If filter paper is necessary, center filter paper over one screen of the applied voltage cell. Trowel sealant over brass shims adjacent to applied voltage cell body. Carefully remove filter paper. Press specimen onto screen; remove or smooth excess sealant which has flowed out of specimen-cell boundary.

10.2.3 *High Viscosity Specimen-Cell Sealant*—Set specimen onto screen. Apply sealant around specimen-cell boundary.

10.2.4 Cover exposed face of specimen with an impermeable material such as rubber or plastic sheeting. Place rubber stopper in cell filling hole to restrict moisture movement. Allow sealant to cure per manufacturer’s instructions.

10.2.5 Repeat steps 10.2.2 (or 10.2.3) and 10.2.4 on second half of cell. (Specimen in applied voltage cell now appears as shown in Fig. 4.)

10.3 Specimen mounting (rubber gasket alternative): Place a 100 mm outside diameter by 75 mm inside diameter by 6 mm thick circular vulcanized rubber gasket in each half of the test cell. Insert sample and clamp the two halves of the test cell together to seal.

10.4 Fill the side of the cell containing the top surface of the specimen with 3.0 % NaCl solution. (That side of the cell will be connected to the negative terminal of the power supply in 10.5.) Fill the other side of the cell (which will be connected to the positive terminal of the power supply) with 0.3 N NaOH solution.

10.5 Attach lead wires to cell banana posts. Make electrical connections to voltage application and data readout apparatus as appropriate; for example, for system listed in 7.7.1 – 7.7.5, connect as shown in Fig. 5. Turn power supply on, set to 60.0 ± 0.1 V, and record initial current reading. Temperatures of the specimen, applied voltage cell, and solutions shall be 20 to 25 °C at the time the test is initiated, that is, when the power supply is turned on.

10.6 During the test, the air temperature around the specimens shall be maintained in the range of 20 to 25 °C.

10.7 Read and record current at least every 30 min. If a voltmeter is being used in combination with a shunt resistor for the current reading (see Fig. 5), use appropriate scale factors to convert voltage reading to amperes. Each half of the test cell must remain filled with the appropriate solution for the entire period of the test.

NOTE 7—During the test, the temperature of the solutions should not be allowed to exceed 90 °C in order to avoid damage to the cell and to avoid boiling off the solutions. Although it is not a requirement of the method, the temperature of the solutions can be monitored with thermocouples installed through the 3-mm venthole in the top of the cell. High temperatures occur only for highly penetrable concretes. If a test of a 50-mm thick specimen is terminated because of high temperatures, this should be noted in the report, along with the time of termination, and the concrete rated as having very high chloride ion penetrability.

10.8 Terminate test after 6 h, except as discussed in Note 7.

10.9 Remove specimen. Rinse cell thoroughly in tapwater; strip out and discard residual sealant.

11. Calculation

11.1 Plot current (in amperes) versus time (in seconds). Draw a smooth curve through the data, and integrate the area underneath the curve in order to obtain the ampere-seconds, or coulombs, of charge passed during the 6-h test period. (See Note 8) Alternatively, use automatic data processing equipment to perform the integration during or after the test and to display the coulomb value. The total charge passed is a measure of the electrical conductance of the concrete during the period of the test.

NOTE 8—*Sample Calculation*—If the current is recorded at 30 min intervals, the following formula, based on the trapezoidal rule, can be used with an electronic calculator to perform the integration:

$$Q = 900 (I_0 + 2I_{30} + 2I_{60} + \dots + 2I_{300} + 2I_{330} + I_{360}) \quad (1)$$

where:

Q = charge passed (coulombs),

I_0 = current (amperes) immediately after voltage is applied, and

I_t = current (amperes) at t min after voltage is applied.

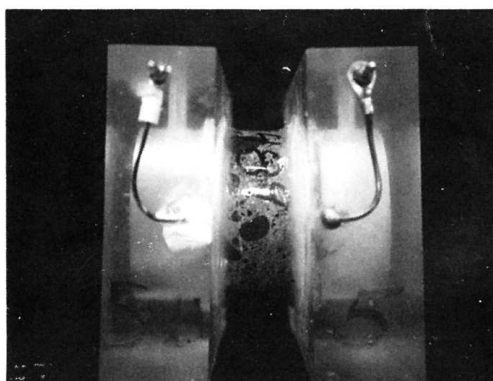

FIG. 4 Specimen Ready for Test