



Designation: C1582/C1582M – 11 (Reapproved 2017)^{ε1}

Standard Specification for Admixtures to Inhibit Chloride-Induced Corrosion of Reinforcing Steel in Concrete¹

This standard is issued under the fixed designation C1582/C1582M; the number immediately following the designation indicates the year of original adoption or, in the case of revision, the year of last revision. A number in parentheses indicates the year of last reapproval. A superscript epsilon (ϵ) indicates an editorial change since the last revision or reapproval.

^{ε1} NOTE—Standard designations were corrected editorially in July 2017.

1. Scope*

1.1 This specification covers material for use as chloride-corrosion-inhibiting admixtures for concrete.

1.2 Results of the tests conducted to meet this specification are not to be used to rank the expected field performance of various chloride-corrosion-inhibiting admixtures.

1.3 The values stated in either SI units or inch-pound units are to be regarded separately as standard. The values stated in each system may not be exact equivalents; therefore, each system shall be used independently of the other. Combining values from the two systems may result in non-conformance with the standard.

1.4 *This standard does not purport to address all of the safety concerns, if any, associated with its use. It is the responsibility of the user of this standard to establish appropriate safety and health practices and determine the applicability of regulatory requirements prior to use. (Warning—Fresh hydraulic cementitious mixtures are caustic and may cause chemical burns to skin and tissue upon prolonged exposure.²)*

1.5 *This international standard was developed in accordance with internationally recognized principles on standardization established in the Decision on Principles for the Development of International Standards, Guides and Recommendations issued by the World Trade Organization Technical Barriers to Trade (TBT) Committee.*

¹ This specification is under the jurisdiction of ASTM Committee C09 on Concrete and Concrete Aggregates and is the direct responsibility of Subcommittee C09.23 on Chemical Admixtures.

Current edition approved June 15, 2017. Published July 2017. Originally approved in 2004. Last previous edition approved in 2011 as C1582/C1582M – 11. DOI: 10.1520/C1582_C1582M-11R17E01.

² Section on Safety Precautions, Manual of Aggregate and Concrete Testing, *Annual Book of ASTM Standards*, Vol 04.02.

2. Referenced Documents

2.1 *ASTM Standards*:³

C39/C39M Test Method for Compressive Strength of Cylindrical Concrete Specimens

C78/C78M Test Method for Flexural Strength of Concrete (Using Simple Beam with Third-Point Loading)

C125 Terminology Relating to Concrete and Concrete Aggregates

C143/C143M Test Method for Slump of Hydraulic-Cement Concrete

C150/C150M Specification for Portland Cement

C157/C157M Test Method for Length Change of Hardened Hydraulic-Cement Mortar and Concrete

C231/C231M Test Method for Air Content of Freshly Mixed Concrete by the Pressure Method

C260/C260M Specification for Air-Entraining Admixtures for Concrete

C403/C403M Test Method for Time of Setting of Concrete Mixtures by Penetration Resistance

C494/C494M Specification for Chemical Admixtures for Concrete

C666/C666M Test Method for Resistance of Concrete to Rapid Freezing and Thawing

C1152/C1152M Test Method for Acid-Soluble Chloride in Mortar and Concrete

G15 Terminology Relating to Corrosion and Corrosion Testing (Withdrawn 2010)⁴

G109 Test Method for Determining Effects of Chemical Admixtures on Corrosion of Embedded Steel Reinforcement in Concrete Exposed to Chloride Environments

G180 Test Method for Corrosion Inhibiting Admixtures for Steel in Concrete by Polarization Resistance in Cementitious Slurries

³ For referenced ASTM standards, visit the ASTM website, www.astm.org, or contact ASTM Customer Service at service@astm.org. For *Annual Book of ASTM Standards* volume information, refer to the standard's Document Summary page on the ASTM website.

⁴ The last approved version of this historical standard is referenced on www.astm.org.

*A Summary of Changes section appears at the end of this standard

2.2 *American Concrete Institute Standard:*⁵
ACI 211.1 Practice for Selecting Proportions of Normal, Heavyweight, and Mass Concrete

3. Terminology

3.1 *Definitions*—Refer to Terminologies **C125** and **G15** for definitions of terms used in this specification.

3.2 *Definitions of Terms Specific to This Standard:*

3.2.1 *chloride-ion content, n*—the acid-soluble chloride-ion content, measured according to Test Method **C1152/C1152M**, of a powder sample taken at a depth equal to the depth of reinforcement.

3.2.2 *completion of testing, n*—for Test Method **G109**, when the following conditions are satisfied: (1) the mean integrated macrocell current in the control beams is greater than or equal to 150 coulombs (C); and (2) the mean chloride-ion content of the test beams is greater than or equal to the critical chloride-ion content.

3.2.2.1 *Discussion*—Refer to the Appendix for additional explanation of the methodology used to evaluate the performance of a chloride-corrosion-inhibiting admixture.

3.2.3 *control beams, n*—beams subjected to the treatment in Test Method **G109** that are made from concrete without the chloride-corrosion-inhibiting admixture.

3.2.4 *critical chloride-ion content, n*—the mean chloride-ion content in the unreinforced control beams at t_{50} plus the standard deviation.

3.2.5 *reinforced beams, n*—beams used to measure macrocell corrosion current according to Test Method **G109**.

3.2.6 t_{50} , *n*—time when the mean integrated macrocell current of the control beams reaches 50 C.

3.2.7 t_{150} , *n*—time when the mean integrated macrocell current of the control beams reaches 150 C.

3.2.8 *test beams, n*—beams subjected to the treatment in Test Method **G109** that are made from concrete with the chloride-corrosion-inhibiting admixture.

3.2.9 *unreinforced beams, n*—beams without reinforcement that are subjected to the cyclic ponding and drying treatment in Test Method **G109** and used to determine chloride-ion content.

4. General Requirements

4.1 For initial compliance with this specification, test-concrete made with the chloride-corrosion-inhibiting admixture shall conform to the requirements prescribed in **Table 1**.

4.2 The purchaser is allowed to require a limited retesting to confirm current compliance of the admixture to specification requirements. The limited retesting covers physical and chemical properties and performance of the admixture.

4.2.1 The physical properties retesting shall consist of uniformity and equivalence tests for infrared analysis, residue by oven drying, and specific gravity as described in Specification **C494/C494M**.

TABLE 1 Physical Requirements of Concrete Containing a Chloride-Corrosion-Inhibiting Admixture

Time of setting, allowable deviation from control, h:min		
Initial: not more than 3:30 earlier or later		
Final: not more than 3:30 earlier or later		
Strength:		
Age	Compressive strength, min. % of control: ^{A,B}	Flexural strength, min. % of control: ^{A,B}
3 days	80	80
7 days	80	80
28 days	80	80
6 months	80	
1 year	80	
Length change, max. shrinkage (alternative requirements) ^C		
Percent of control: 135		
Increase over control, percentage points: 0.010		
Relative durability factor, minimum %: 80		

^A The values in the table include allowance for normal variation in test results. The objective of the 80 % relative strength is to require a level of performance comparable to that of the control concrete. Reinforced concrete, subjected to brackish water, salt spray and/or deicers, requires a water-cement ratio of 0.40 or less for long-term durability. This durability requirement results typically in compressive strengths in excess of what is required structurally. If high-strength concrete is needed for structural purposes, mixture proportions may need to be adjusted when using a chloride-corrosion-inhibiting admixture.

^B The compressive and flexural strength of the concrete containing the admixture under test at any test age shall not be less than 90 % of that attained at any previous test age. The objective of this limit is to require that the compressive or flexural strength of the concrete containing the admixture under test shall not decrease with age.

^C For the alternative requirements (see Specification **C494/C494M**), the percent of control limit applies when length change of the control concrete is 0.030 % or greater, and the increase over control limit applies when length change of the control concrete is less than 0.030 %.

4.2.2 The performance property retesting shall consist of time of setting and compressive strength at 3, 7, and 28 days. Purchasers having special requirements are allowed to require additional tests currently in this standard.

4.3 At the request of the purchaser, the manufacturer shall state in writing that the admixture supplied for use in the project is identical in all essential respects, including concentration, to the admixture tested under this specification and found to comply therewith.

4.4 Tests for uniformity and equivalence shall be made on the initial sample in accordance with Specification **C494/C494M**, and the results retained for reference and comparison with the results of tests of samples taken from elsewhere within the lot or subsequent lots of admixture supplied for use in the project.

5. Corrosion-Inhibiting Performance

5.1 In addition to producing concrete that meets the requirements in **Table 1**, the test admixture must show corrosion-inhibiting performance as summarized in **Table 2** when tested in accordance with Test Method **G109** with reinforcing bar depths and mixture proportions as specified in Sections **10** and **11** of this specification, or in accordance with Test Method **G180** using 0.5 M NaCl as specified in Section **15**.

5.2 The following requirements must be attained when Test Method **G109** is used:

⁵ Available from American Concrete Institute (ACI), P.O. Box 9094, Farmington Hills, MI 48333-9094, <http://www.concrete.org>.

TABLE 2 Corrosion-Inhibiting Requirements

When evaluated using Test Method G109	
Mean integrated macrocell current of test beams, C^A	≤ 50
Mean corroded area of test beams, fraction of control ^A	$\leq \frac{1}{3}$
When evaluated using Test Method G180	
Mean 1/R _p compared to control ^B	$\leq \frac{1}{6}$

^A At completion of testing using Test Method **G109** and based on a minimum of three specimens of control and test concrete, and discarded specimens are not included.

^B Test Method **G180** at 0.5 M NaCl with four control and four test specimens.

5.2.1 At completion of testing (see 3.2.2), the mean integrated macrocell current of the test beams must be less than or equal to 50 C.

5.2.2 At completion of testing, the mean corroded area of the top reinforcing steel in the test beams must be less than or equal to $\frac{1}{3}$ of the mean corroded area of the top steel in the control beams.

5.2.3 At the completion of testing, the mean chloride-ion content of the test beams must be greater than or equal to the critical chloride-ion content.

5.3 If Test Method **G180** is used, the average polarization resistance, R_p , of the test specimens with the corrosion inhibitor shall be at least 8 times greater than that of the control specimens.

6. Packaging and Package Marking

6.1 When the admixture is delivered in packages or containers, the proprietary name of the admixture and the net mass or volume shall be plainly marked thereon. Similar information shall be provided in the shipping information accompanying packaged or bulk shipments of admixtures.

7. Storage

7.1 Store the admixture so as to permit easy access for proper inspection and identification of each shipment, and in a suitable weather-tight building that will protect the admixture from dampness and freezing.

8. Sampling and Inspection

8.1 Sampling and inspection shall be in accordance with Specification **C494/C494M**.

9. Rejection

9.1 For initial compliance testing, the purchaser is allowed to reject the admixture if it fails to meet any of the applicable requirements for this specification.

9.2 For limited retesting, the purchaser is allowed to reject the admixture if it fails to meet any of the requirements of the Uniformity and Equivalence Section of Specification **C494/C494M** and of the applicable parts of **Table 1** of this standard.

9.3 An admixture stored at the point of manufacture, for more than 6 months prior to shipment, or an admixture in local storage in the hands of a vendor for more than 6 months, after completion of tests, shall be retested before use when requested

by the purchaser and is allowed to be rejected if it fails to conform to any of the applicable requirements of this specification.

9.4 Packages or containers varying more than 5 % from the specified mass or volume are allowed to be rejected. If the average mass or volume of 50 packages taken at random is less than that specified, the entire shipment is allowed to be rejected.

9.5 When the admixture is to be used in non-air-entrained concrete, it shall be rejected when the purchaser desires if the test concrete containing it has an air content greater than 3.5 %; when the admixture is to be used in air-entrained concrete, it shall be rejected when the purchaser desires if the test concrete containing it has an air content greater than 7.0 %.

TEST METHODS

NOTE 1—These tests are based on arbitrary stipulations which make possible highly standardized testing in the laboratory and are not intended to simulate actual job conditions.

10. Test Specimens

10.1 Two types of concrete are used to make test specimens. One, the control concrete, is made without the chloride-corrosion-inhibiting admixture. The other concrete, the test concrete, is made with the chloride-corrosion-inhibiting admixture. Do not use cement that causes the air content of the control concrete made without the subject admixture to exceed 3.0 %.

10.2 Make specimens for measuring compressive strength, flexural strength, resistance to freezing and thawing, and length change in accordance with Specification **C494/C494M**. Prepare three separate batches of each concrete mixture in accordance with Specification **C494/C494M**, and report the mean test results from the three batches.

10.3 When corrosion performance will be determined by Test Method **G109**, make specimens for corrosion testing and chloride-ion analysis from a separate batch of each concrete. For each concrete mixture, make at least three beams with steel reinforcement in accordance with Test Method **G109**, and make at least three beams of the same size without reinforcement (**Note 2**). The reinforcement shall be deformed bars designation No. 4 [13] with a nominal diameter of $\frac{1}{2}$ in. [12.7 mm] and the cover depth shall be 1.0 ± 0.1 in. [25 ± 3 mm]. Subject all beams to the same cyclic ponding and drying treatment described in Test Method **G109**.

NOTE 2—The reinforced beams are used to determine the macrocell corrosion current as a function of time, and the unreinforced beams are used to determine the chloride-ion content at specified times.

11. Specimen Preparation

11.1 *Mixture Proportions*—Proportion all concrete mixtures to conform to the requirements described in 11.1.1 through 11.1.5. Unless otherwise specified, include the chloride-corrosion-inhibiting admixture with the first increment of mixing water that is added to the mixer.

11.1.1 The water-cement ratio shall be 0.50 ± 0.01 and the cement content shall be between 550 and 650 lb/yd³ [325 and 385 kg/m³]. The test and control mixtures are to have water and cement contents equivalent to within ± 1 % by mass.

11.1.2 Cement shall meet the requirements of a Type II cement according to Specification **C150/C150M**.

NOTE 3—Type II cement is used to limit the tricalcium aluminate (C₃A) content and is not intended as design guidance for specific projects.

11.1.3 The grading of the coarse aggregate shall comply with size number 7 or 8 of Specification C33, that is, the nominal maximum size is ½ in. [12.5 mm] or ⅜ in. [9.5 mm]. For the first trial mixture, refer to ACI 211.1 for guidance on the amount of coarse aggregate to use based on the fineness modulus of the fine aggregate.

NOTE 4—Tabulated values of coarse aggregate content given in ACI 211.1 are intended to ensure workable mixtures with the least favorable combinations of aggregate likely to be used. It is suggested, therefore, that for a closer approximation of the required proportions, the volume of coarse aggregate (in the dry-rodded condition) per unit volume of concrete selected from ACI 211.1 be increased by about 0.07 for the first trial mixture.

11.1.4 For air-entrained concrete, the air content of the fresh concrete shall be 6 ± 1 % as measured according to Test Method **C231/C231M**. For concrete that is not air-entrained, the air content of the fresh concrete shall be less than 3.5 % as measured according to Test Method **C231/C231M**.

11.1.5 The slump shall be greater than or equal to 3 in. [75 mm] and less than or equal to 8 in. [200 mm] as measured according to Test Method **C143/C143M**. The use of a water-reducing admixture is not prohibited to obtain the required slump, but the same quantity must be used in the control concrete and in the test concrete.

11.2 *Quantity of Concrete*—Prepare concrete mixtures with and without the chloride-corrosion-inhibiting admixture in sufficient volume to produce specimens needed for performing the tests listed in **Table 1** and for corrosion testing.

NOTE 5—The required quantity of concrete for each batch depends on the number of extra specimens that are cast. It is recommended that more than the required minimum number of specimens be cast in case some of them are faulty. If one time of setting specimen and the minimum number of 6- by 12-in. [150- by 300-mm] cylinders, 3- by 4- by 16-in. [75- by 100- by 410-mm] freezing and thawing prisms, 6- by 6- by 21-in. [150- by 150- by 535-mm] flexural beams, and 3- by 3- by 11.25-in. [75- by 75- by 285-mm] length-change prisms are made, the required volume of concrete is 3.1 ft³ [0.087 m³]. Twice this amount is used typically to allow for extra specimens. The minimum of three reinforced beams and three unreinforced beams for corrosion testing requires about 1.1 ft³ [0.029 m³] of concrete. Additional unreinforced beams are recommended for chloride ion analysis in the event that specimens are faulty, and additional reinforced beams are recommended to ensure that the criterion in **14.6.3** is satisfied at the completion of testing. Each additional beam requires about 0.2 ft³ [0.005 m³] of concrete.

11.3 *Admixture Dosage*—Add the chloride-corrosion-inhibiting admixture at the dosage recommended by the manufacturer.

11.4 *Specimen Fabrication and Curing*—Make and cure test specimens for measuring strength, resistance to freezing and thawing, and length change in accordance with Specification **C494/C494M**. Make and cure specimens for corrosion testing and chloride-ion determination in accordance with Test Method **G109**.

12. Tests of Freshly Mixed Concrete

12.1 *Slump*—Test Method **C143/C143M**.

12.2 *Air Content*—Test Method **C231/C231M**.

12.3 *Time of Setting*—Test Method **C403/C403M**. Store the time-of-setting specimens at 73.5 ± 3.5 °F [23.0 ± 2.0 °C] during the test period.

13. Tests of Hardened Concrete

13.1 *Compressive Strength*—Test Method **C39/C39M**. Measure compressive strength at ages of 3 days, 7 days, 28 days, 6 months, and 1 year. For each test age, divide the mean strength of the test concrete specimens by the mean strength of the control concrete specimens and multiply the quotient by 100.

13.2 *Flexural Strength*—Test Method **C78/C78M**. Measure flexural strength at ages of 3, 7, and 28 days. For each test age, divide the mean strength of the test concrete specimens by the mean strength of the control concrete specimens and multiply the quotient by 100.

13.3 *Resistance to Freezing and Thawing*—Test Method **C666/C666M**, Procedure A. Calculate the relative durability factor in accordance with Specification **C260/C260M**.

13.4 *Length Change*—Test Method **C157/C157M** as modified by Specification **C494/C494M**.

14. Corrosion Testing When Using Test Method G109

14.1 *General*—Test the corrosion performance of the reinforced control beams and the reinforced test beams according to Test Method **G109**, except as noted in this specification. Subject the reinforced and unreinforced beams to the same cyclic ponding and drying process that is described in Test Method **G109**. Chloride-ion content measurements are made when the mean integrated macrocell current in the control beams reaches 50 C and 150 C. The criteria for completion of testing are specified in **3.2.2**.

NOTE 6—**Appendix X1** provides a flowchart to explain further the corrosion testing procedure. The flowchart includes references to the corresponding section numbers in this specification.

14.2 *Tests at t₅₀*—Measure the integrated macrocell current in the reinforced beams as specified in Test Method **G109**. When the mean integrated macrocell current of the reinforced control beams reaches 50 C, determine the mean chloride-ion content of the companion unreinforced control beams in accordance with **14.2.1** and **14.2.2**.

14.2.1 Obtain powder samples for chloride-ion content analysis by drilling into the sides of three unreinforced control beams at the level of the reinforcing steel in the reinforced beams. For each beam, drill holes at three locations directly below the plastic dam (see **Fig. 1(a)**). Use a ½-in. [13-mm] drill bit, and locate the center of each hole so that it coincides with the depth of the center of the bar in the reinforced beams. Discard the powder obtained from the outermost 1.0 ± 0.1 in. [25 ± 3 mm] of each hole, clean powder from the drill bit, and collect at least a 10-g powder sample from each hole. Discontinue cyclic ponding of the tested unreinforced control beam after chloride-ion content sampling.

14.2.2 Measure the acid-soluble chloride-ion content of each powder sample in accordance with Test Method **C1152/C1152M**. Compute the mean and standard deviation of the nine chloride-ion measurements. Calculate the critical chloride-ion content as the mean plus the standard deviation of the nine measurements.

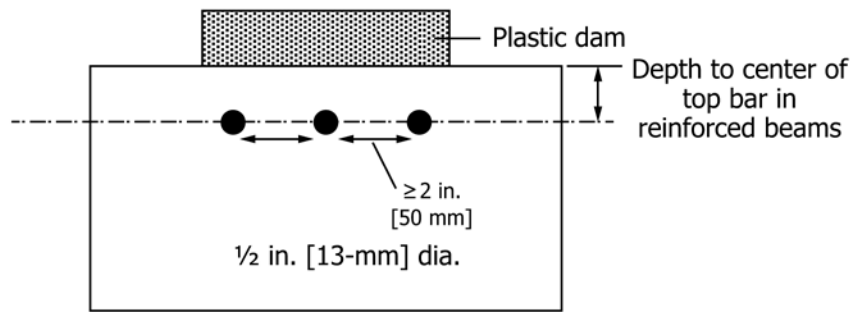

(a) Sampling of control beams at t_{50}

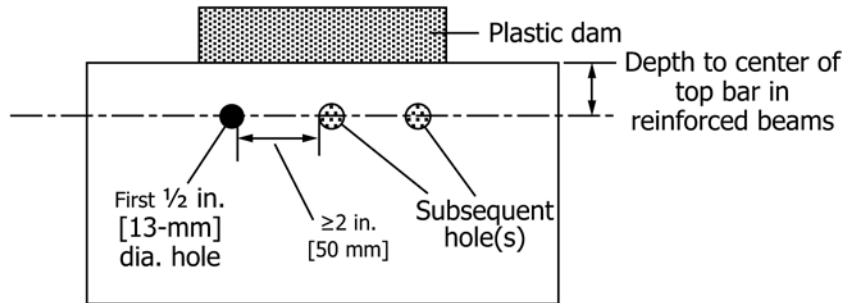

(b) Sampling of test beams at t_{150} or later

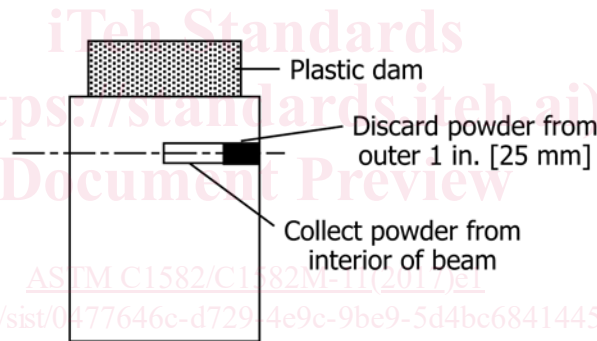

(c) Section view of sampling procedure

FIG. 1 Sampling of Unreinforced Beams for Chloride-Ion Content Determination

14.3 *Tests at t_{150}* —Continue the cyclic ponding and drying process and measurement of the integrated macrocell current in accordance with Test Method G109. When the mean integrated macrocell current of the reinforced control beams reaches 150 C, determine the mean chloride-ion content of the unreinforced test beams in accordance with 14.3.1 and 14.3.2.

14.3.1 Obtain one 10-g powder sample from each of three unreinforced test beams using the sampling procedure in 14.2.1. Drill the hole in each beam so that it is below the dam and near one end (see Fig. 1(b)). If additional cyclic ponding and drying is required in accordance with 14.5, fill the holes with the epoxy of the kind that was used to seal the beams. Ensure that surfaces surrounding the holes are sealed.

14.3.2 Measure the acid-soluble chloride-ion content of each powder sample in accordance with Test Method C1152/C1152M. Calculate the mean chloride-ion content of the three samples from the test beams.

14.4 *Completion of Testing*—If the mean chloride-ion content of the test beams at t_{150} is greater than the critical chloride-ion content, testing is completed. Perform a destructive examination of the control and test beams as described in 14.6.

14.5 *Additional Testing*—If the mean chloride-ion content of the test beams at t_{150} is less than the critical chloride-ion content and the mean integrated macrocell current of the test beams is less than 50 C, continue corrosion testing according to Test Method G109 for the additional number of cycles determined in 14.5.1. If the mean integrated macrocell current of the test beams at t_{150} is more than 50 C, the admixture fails to meet this specification.

14.5.1 Based on the mean chloride-ion content of the test beams determined at t_{150} and assumed chloride-ion content of zero at start of testing, estimate the additional cyclic ponding

time required to obtain a chloride-ion content equal to or greater than the critical chloride-ion content. Use linear extrapolation for this estimate. If the estimated time is more than 12 cycles of ponding and drying, obtain powder samples according to 14.5.2 after an additional testing time of 12 cycles. If one or more of the control beams crack before reaching the planned additional cycles of ponding and drying, stop testing, obtain powder samples from the unreinforced test beams according to 14.5.2, and perform a destructive examination of the control and test beams as described in 14.6.

14.5.2 After additional cyclic ponding and drying, determine the chloride-ion content in the test beams by sampling from one drill hole in each of three unreinforced test beams as described in 14.2.1. Locate the center of the new hole in each beam so that it is below the dam but no closer than 2 in. [50 mm] to the hole drilled previously (see Fig. 1(b)). If additional cyclic ponding and drying is required in accordance with 14.5.6, fill the holes with epoxy, and ensure that surfaces surrounding the holes are sealed.

14.5.3 Measure the acid soluble chloride-ion content of each powder sample in accordance with Test Method C1152/C1152M. Calculate the mean chloride-ion content of the three samples from the test beams.

14.5.4 If the mean chloride-ion content calculated in 14.5.3 is equal to or greater than the critical chloride-ion content, testing is completed. Perform a destructive evaluation of the control and test beams in accordance with 14.6.

14.5.5 If the mean chloride-ion content is less than the critical chloride-ion content and the control beams are not cracked, make a new estimate of the time to reach the critical chloride-ion content. Repeat the procedure starting at 14.5.2 until the mean chloride-ion content is equal to or greater than the critical chloride-ion content, or the total time of corrosion testing exceeds five years.

14.5.6 If testing is stopped because of cracking in control beams and the mean chloride-ion content of the test beams is equal to or greater than the critical chloride-ion content, perform a destructive evaluation in accordance with 14.6.

14.6 *Destructive Examination*—Cut each reinforced beam longitudinally above and below the top reinforcing bar using a water-cooled diamond tipped concrete saw. Use care not to cut the bar. Break the test beam in half and extract the top reinforcing bar. Avoid wetting the top bar during extraction. If the bar is wetted, dry immediately and store in an environment at less than 50 % relative humidity until inspection according to 14.6.2.

14.6.1 Make additional saw cuts, and extract the bottom bars from each beam. If the bars are wetted, dry immediately and store in an environment at less than 50 % relative humidity until inspection according to 14.6.2.

14.6.2 Visually inspect the top- and bottom-reinforcing bars, photograph the bars, and estimate the percentage of corroded area on each bar as instructed in Test Method G109.

14.6.3 If the corroded area on the bottom bars from any test beam is greater than 1 % of the exposed area, the test results from that beam are invalid. Substitute the results of a valid backup beam if available.

NOTE 7—Bottom bar corrosion can occur in situations such as: when an

aggressive agent is present in the concrete; the exterior coating does not properly seal around the bottom bars; or the bottom of the test specimen is cracked.

14.7 *Evaluation of Results*—At completion of testing, evaluate whether the test concrete satisfies the performance criteria.

14.7.1 If the mean integrated macrocell current of the test beams is less than 50 C, the performance criterion in 5.2.1 is satisfied.

14.7.2 If the mean percentage of corroded area of the top reinforcing bars extracted from the test beams is less than 1/3 the mean percentage of corroded area of the control beams, the performance criterion in 5.2.2 is satisfied.

14.7.3 If after five years of corrosion testing, the chloride-ion content in the test beams is less than the critical chloride-ion content, the admixture does not qualify as a chloride-corrosion-inhibiting admixture under this specification.

14.7.4 If one or more of the control beams crack and the mean chloride-ion content of the test beams is less than the critical chloride-ion content, the admixture does not qualify as a chloride-corrosion-inhibiting admixture under this specification.

15. Corrosion Testing When Using Method G180

15.1 Test 4 control specimens and 4 specimens with inhibitor in accordance with Test Method G180, except that a 0.5 M NaCl shall be used.

16. Report

16.1 For each mixture, report:

16.1.1 The mixture proportions, cement content, water-cement ratio, quantities of admixtures, slump, and air content.

16.1.2 The mean values of the tests listed in Table 1.

16.2 When Test Method G109 is used for corrosion testing, report the following:

16.2.1 Corrosion data including individual macrocell current values for all beams as described in Test Method G109.

16.2.2 The times in weeks from start of cyclic ponding and drying for control beams to reach an integrated macrocell current of 50 C and 150 C (t_{50} and t_{150} , respectively) and the total time at completion of testing, if longer than t_{150} .

16.2.3 The mean integrated macrocell current of the reinforced control and test beams at completion of testing calculated according to Test Method G109.

16.2.4 The percentage of corroded area for all reinforcing bars, and include photographs of the extracted reinforcing bars.

16.2.5 The average percentage of corroded area for the control beams and the test beams.

16.2.6 The acid-soluble chloride-ion content values, the calculated mean, and standard deviation from the unreinforced control beams sampled at t_{50} .

16.2.7 The acid-soluble chloride-ion content values and the calculated mean from unreinforced test beams at t_{150} , any intermediate sampling time, and the completion of testing.

16.3 When Test Method G180 is used for corrosion testing, report the following:

16.3.1 Dosage of inhibitor added in mL/L.