



Standard Test Method for Fire Testing of School Bus Seat Assemblies¹

This standard is issued under the fixed designation E2574/E2574M; the number immediately following the designation indicates the year of original adoption or, in the case of revision, the year of last revision. A number in parentheses indicates the year of last reapproval. A superscript epsilon (ϵ) indicates an editorial change since the last revision or reapproval.

1. Scope*

1.1 This is a fire-test-response standard.

1.2 This test method assesses the burning behavior of upholstered seating used in school buses by measuring specific fire-test responses when a school bus seat specimen is subjected to a specified flaming ignition source under normally ventilated conditions.

1.3 The ignition source is a gas burner.

1.4 This fire test is primarily useful to distinguish products that, when exposed to an ignition source, will become fully involved in fire from other products that will not.

1.5 Data are obtained describing the burning behavior of the seat assemblies from a specific ignition source until all burning has ceased.

1.6 This test method does not provide information on the fire performance of upholstered seating in fire conditions other than those conditions specified.

1.7 The burning behavior is visually documented by photographic or video recordings, whenever possible.

1.8 The values stated in either SI units or inch-pound units are to be regarded separately as standard. The values stated in each system may not be exact equivalents; therefore, each system shall be used independently of the other. Combining values from the two systems may result in non-conformance with the standard.

1.9 *This standard is used to measure and describe the response of materials, products, or assemblies to heat and flame under controlled conditions, but does not by itself incorporate all factors required for fire hazard or fire risk assessment of the materials, products or assemblies under actual fire conditions.*

1.10 *Fire testing is inherently hazardous. Adequate safeguards for personnel and property shall be employed in conducting these tests.*

1.11 *This standard does not purport to address all of the safety concerns, if any, associated with its use. It is the responsibility of the user of this standard to establish appropriate safety and health practices and determine the applicability of regulatory limitations prior to use.*

1.12 *This international standard was developed in accordance with internationally recognized principles on standardization established in the Decision on Principles for the Development of International Standards, Guides and Recommendations issued by the World Trade Organization Technical Barriers to Trade (TBT) Committee.*

2. Referenced Documents

2.1 ASTM Standards:²

D5132 Test Method for Horizontal Burning Rate of Polymeric Materials Used in Occupant Compartments of Motor Vehicles

E176 Terminology of Fire Standards

E1537 Test Method for Fire Testing of Upholstered Furniture

E1590 Test Method for Fire Testing of Mattresses

E2061 Guide for Fire Hazard Assessment of Rail Transportation Vehicles

E2067 Practice for Full-Scale Oxygen Consumption Calorimetry Fire Tests

E2257 Test Method for Room Fire Test of Wall and Ceiling Materials and Assemblies

F1550 Test Method for Determination of Fire-Test-Response Characteristics of Components or Composites of Mattresses or Furniture for Use in Correctional Facilities after Exposure to Vandalism, by Employing a Bench Scale Oxygen Consumption Calorimeter

IEEE/ASTM SI 10 American National Standard for Metric Practice

2.2 National Safety Council Standard:³

School bus seat upholstery fire block test, approved by the National Conference on School Transportation as part of the National Standards for School Buses and National

¹ This test method is under the jurisdiction of ASTM Committee E05 on Fire Standards and is the direct responsibility of Subcommittee E05.17 on Transportation.

Current edition approved July 1, 2017. Published July 2017. Originally approved in 2011. Last previous edition approved in 2012 as E2574/E2574M-12a. DOI: 10.1520/E2574_E2574M-17.

² For referenced ASTM standards, visit the ASTM website, www.astm.org, or contact ASTM Customer Service at service@astm.org. For *Annual Book of ASTM Standards* volume information, refer to the standard's Document Summary page on the ASTM website.

³ Available from National Safety Council (NSC), 1121 Spring Lake Dr., Itasca, IL 60143-3201, <http://www.nsc.org>.

*A Summary of Changes section appears at the end of this standard

Standards for School Bus Operations

2.3 Federal Motor Vehicle Safety Standards:⁴

FMVSS 222 School Bus Passenger Seating and Crash Protection, U.S. Code of Federal Regulations, Title 49, Transportation, Subtitle B, Chapter V, Part 571, Subpart B.
FMVSS 302 Flammability of Interior Material, U.S. Code of Federal Regulations, Title 49, Transportation, Subtitle B, Chapter V, Part 571, Subpart B

2.4 NFPA Standard:⁵

NFPA 286 Standard Method of Tests for Evaluating Contribution of Wall and Ceiling Interior Finish to Room Fire Growth

3. Terminology

3.1 For definitions of terms used in this test method associated with fire issues, refer to the terminology contained in Terminology **E176**.

3.2 Definitions:

3.2.1 *screening test, n*—as related to fire, a fire-response test performed to determine whether a material, product, or assembly (*a*) exhibits any unusual fire-related characteristics, (*b*) has certain expected fire-related characteristics, or (*c*) is capable of being preliminarily categorized according to the fire characteristic in question.

3.3 Definitions of Terms Specific to This Standard:

3.3.1 *newspaper, n*—as related to this test method, standard size double sheets of newsprint, with black print and no colored ink or surface treatment.

3.3.2 *paper bag, n*—as related to this test method, a bag constructed of unbleached (brown, #30) kraft paper having four sides and a bottom, with an open top, and held together with adhesive.

4. Summary of Test Method

4.1 A mock-up of a school bus is constructed with three rows of actual seats.

4.2 A gas burner ignition source is used.

4.3 Each test consists of two trials. In each trial a gas burner ignition source is placed at a specified location to ignite the middle row of seats and is ignited.

4.4 A different gas burner is used for the top of the seat and for the bottom of the seat.

4.5 Once flame extinction has occurred, the time to flame extinction, the extent of fire spread (within the seat and to the other seats if applicable) and the mass loss of the seat are assessed.

5. Significance and Use

5.1 In this test method fire test response characteristics of a school bus seat assembly are assessed following ignition by a square gas burner.

⁴ Available from Superintendent of Documents, U.S. Government Printing Office, Washington, DC 20402.

⁵ Available from National Fire Protection Association (NFPA), 1 Batterymarch Park, Quincy, MA 02169-7471, <http://www.nfpa.org>.

5.2 This test method is similar in concept to a fire test currently used, and which has been in such use for many years, as the industry standard for flammability testing of school bus seats (see **Appendix X1**). However, in this test method the paper bag has been replaced by a gas burner as the ignition source.

5.3 The US federal government has issued a flammability test applicable to interior materials in road vehicles, FMVSS 302. FMVSS 302 remains the only regulatory test for assessing fire-test-response characteristics of school bus seats.

5.4 ASTM has issued Test Method **D5132** in order to provide a more standardized way of conducting FMVSS 302.

5.5 The test method described in this document provides a significantly higher challenge to school bus seats than the FMVSS 302 federal regulatory test. Therefore, any seat assembly that performs acceptably in this test is likely to meet the requirements of FMVSS 302.

5.6 It is clear that those seat assemblies that exhibit little or no flame spread, short times to flame extinction and little mass loss in this test are likely to exhibit improved performance in an actual fire situation compared to seat assemblies that burn vigorously and have high mass loss.

5.7 This test is primarily useful to distinguish products that, when exposed to these fire conditions, will become fully involved in fire from other products that will not.

6. Apparatus: Test Chamber

6.1 *General*—The test chamber shall be either an actual section of a school bus or it shall comply with the cross section requirements of **6.2.2**. **Fig. 1** describes the test chamber.

6.2 Cross Section:

6.2.1 Use a test chamber that has the same cross section as the body of an actual school bus, in which the seats are intended to be used, with a rear section on each end.

6.2.2 The test chamber cross section shall be 2300 ± 30 mm [91 ± 1 in.] in width by 1900 ± 80 mm [75 ± 3 in.] in height.

6.3 The test chamber shall have a door, which is not intended for use to provide ventilation, in the center of each end of the test chamber. The door shall be 970 ± 80 mm [38 ± 3 in.] in width by 1270 ± 80 mm [53 ± 3 in.] in height and it shall include a latch to keep the door closed during the test. See **Fig. 1**.

6.4 *Length*—The length of the test chamber shall be such as to allow three rows of seats at the minimum spacing recommended by the installer or as required by FMVSS 222. See **Fig. 1, Detail A**.

6.4.1 In order for different types of seats to be able to be tested in the same chamber, a length tolerance of plus 1140 mm [45 in.] shall be allowed.

6.5 *Ventilation*—There shall be two ventilation openings in the test chamber, one at each end. Each opening shall have an opening area of 0.210 ± 0.016 m² [325 ± 25 in.²]. The bottom of the opening shall be 760 ± 80 mm [30 ± 3 in.] above the chamber floor.

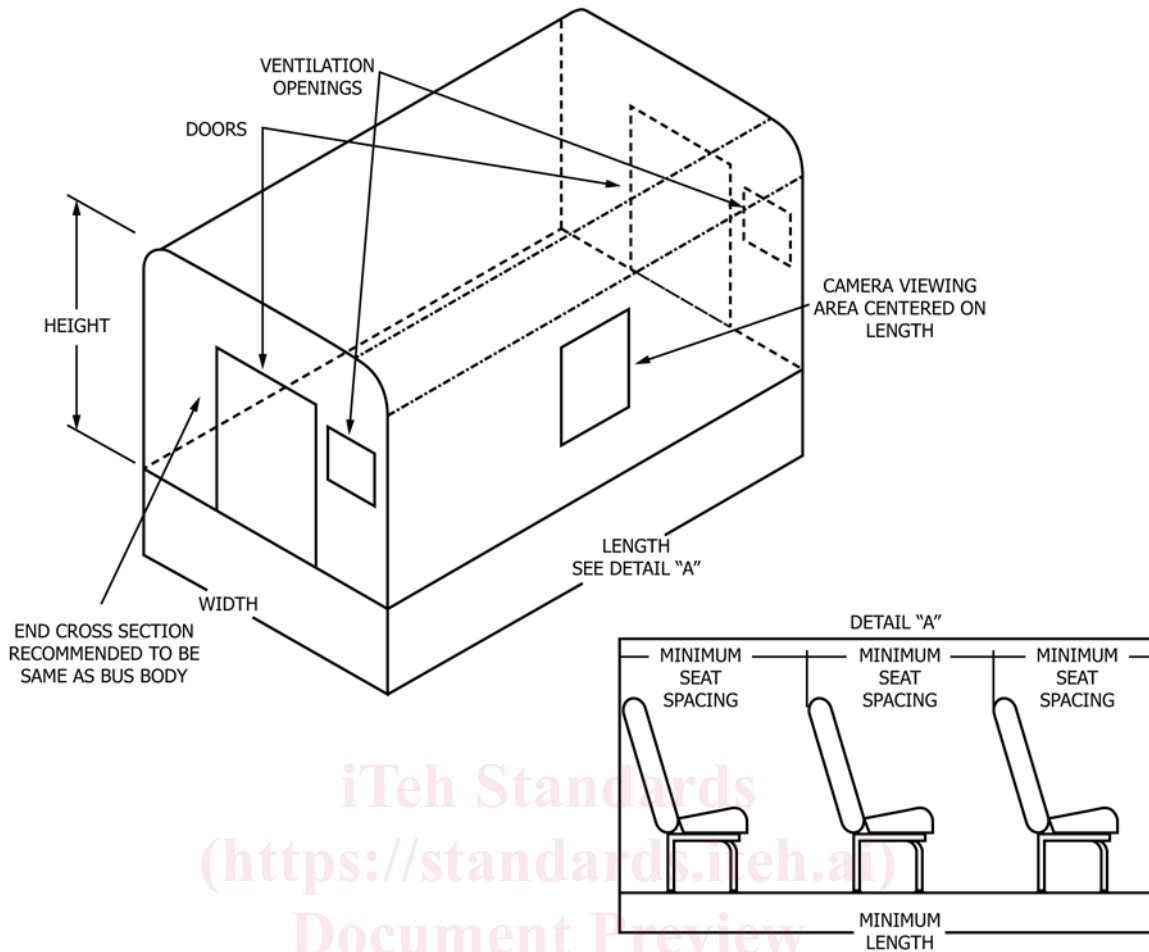

FIG. 1 Test Chamber

6.5.1 There shall be no ventilation openings along the length of the test chamber.

6.5.2 There shall be no forced air ventilation system. Baffles shall be used to prevent wind from blowing directly into the ventilation openings.

6.6 *Camera View Area*—A viewing area (such as an opening covered with a glazing material) shall be provided at the midpoint of the chamber length for camera viewing. The opening shall allow the camera to view the seat parallel to the seat width. See Fig. 1.

7. Ignition Sources

7.1 *Top of the Seat:*

7.1.1 For the top of the seat use the square gas burner described in Figs. 2-7.

NOTE 1—This is essentially the same burner used in Test Method E1537, except for the arm.

7.1.2 Construct the 250 ± 10 by 250 ± 10 mm [approximately 10 by 10 in.] square burner of 13 ± 1 mm [0.5 in.] outside diameter stainless steel tubing, with 0.89 ± 0.05 mm [0.035 in.] wall thickness (see Fig. 2). The front side shall have 14 holes pointing straight out and spaced 13 ± 1 mm [0.5 in.] apart and nine holes pointing straight down and spaced 13 ± 1 mm [0.5 in.] apart. The right and left sides shall have six holes

pointing straight out and spaced 13 ± 1 mm [0.5 in.] apart and four holes pointing inward at a 45° angle and spaced 50 ± 2 mm [2 in.] apart. All holes shall be of 1 ± 0.05 mm [0.039 in.] diameter (see Fig. 2, Fig. 3 and Fig. 4). The burner shall have an arm 288 ± 10 mm [11.3 ± 0.4 in.] long and welded on to the rear of the front side (see Fig. 3) at a 30° angle. The arm shall then include a vertical length before extending horizontally for a length appropriate for the stand being used (see Figs. 5-7). Mount the burner on an adjustable height pole at a height of 460 ± 13 mm [18 ± 0.5 in.] and balance it by a counterweight or other appropriate mechanism (see Fig. 4).

NOTE 2—**Warning**—It is common for the burner holes to become clogged up following a test. Inspect burner holes after each test, and clean thoroughly, if required. Take care not to enlarge the holes when cleaning them.

7.2 *Under the Seat:*

7.2.1 For use underneath the seat the ignition source shall be a gas burner with a nominal 305 by 305 mm [nominal 12 by 12 in.] porous top surface as shown in Fig. 8. This material, through which the gas is supplied, shall be a minimum 102 mm [4 in.] layer of white Ottawa sand used to provide the horizontal surface through which the gas is supplied.

NOTE 3—This is the same burner used in Test Method E2257 and in NFPA 286.

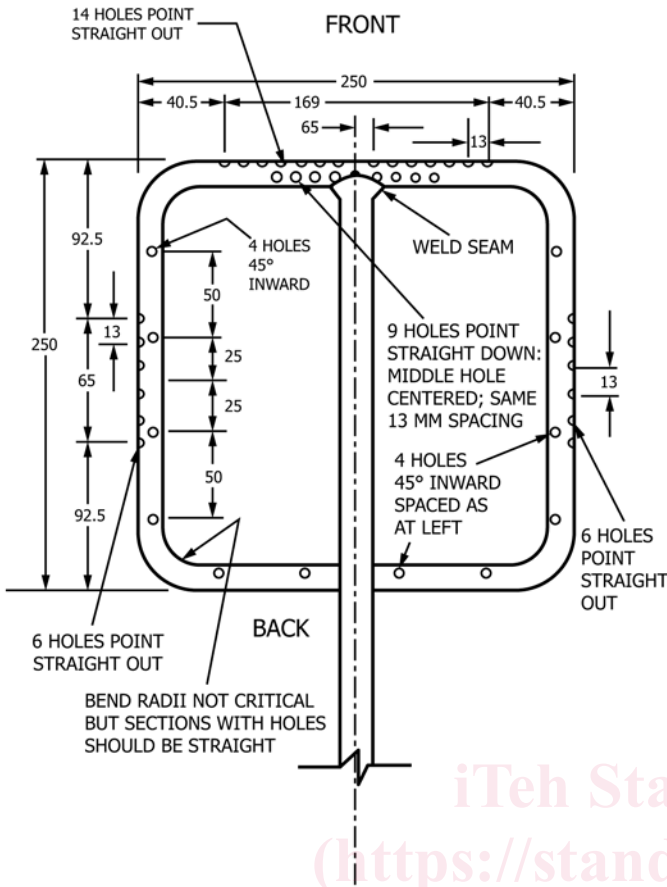

NOTE 1—All tubing 13 mm outside diameter, stainless steel, 0.89 mm wall thickness.

NOTE 2—All holes 1 mm in diameter.

NOTE 3—All units are mm unless otherwise noted.

NOTE 4—See text for tolerances.

FIG. 2 Plan View of Square Gas Burner

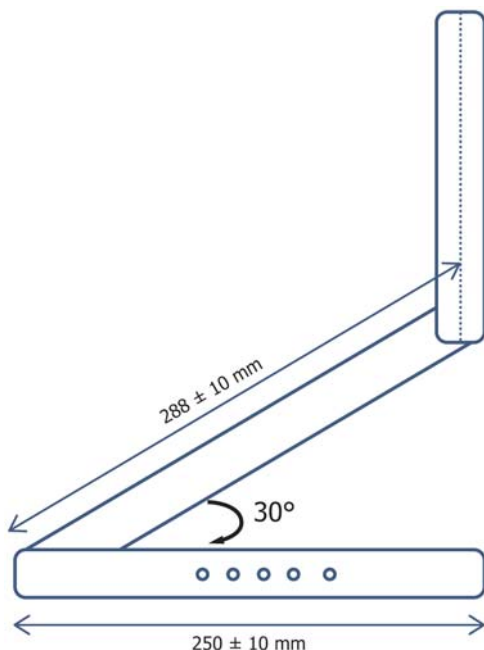

FIG. 3 Side View of Square Gas Burner

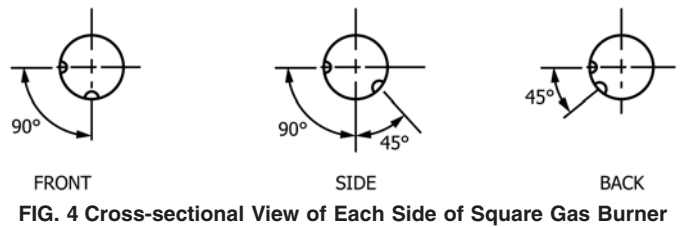

FIG. 4 Cross-sectional View of Each Side of Square Gas Burner

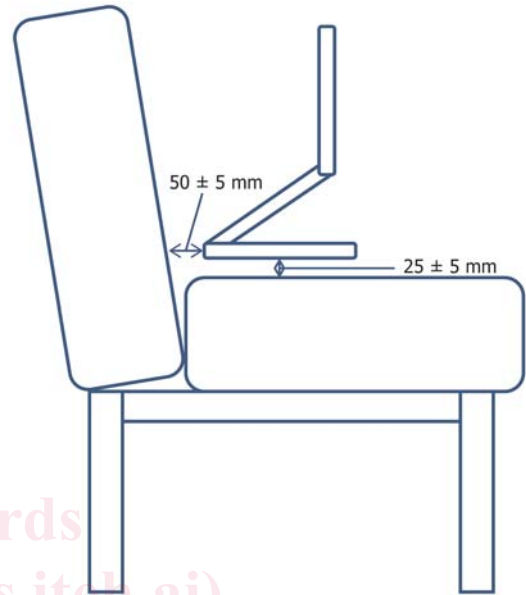

FIG. 5 Top Burner Placement - Side View

7.2.2 The top surface of the burner through which the gas is applied shall be located horizontally 300 ± 50 mm [12 ± 2 in.] above the floor.

7.3 For both ignition sources use propane gas, with a known net heat of combustion of 2050 ± 50 kJ/mol, as a fuel for this ignition source. Meter the flow rate of propane and keep it constant throughout the test.

7.4 For both ignition sources, use the gas burner at a flow rate of 19.5 ± 0.25 L/min for a total of 120 s. Measure the gas flow rate at a pressure of 101 ± 5 kPa (standard atmospheric pressure, measured at the flow gage) and a temperature of $20 \pm 5^\circ\text{C}$.

8. Mass Measurements

8.1 Use a balance that is capable of assessing the mass of the test specimen and of the individual test specimen components with a precision of ± 150 g.

8.2 Calibrate the balance regularly to ensure its accuracy.

9. Test Specimens

9.1 The test specimen shall be a fully-assembled seat.

9.2 Measure the weight of all padding and upholstery prior to assembly.

9.3 Measure the weight of the non-combustible components of the seat (steel frame, etc.). Record this weight.

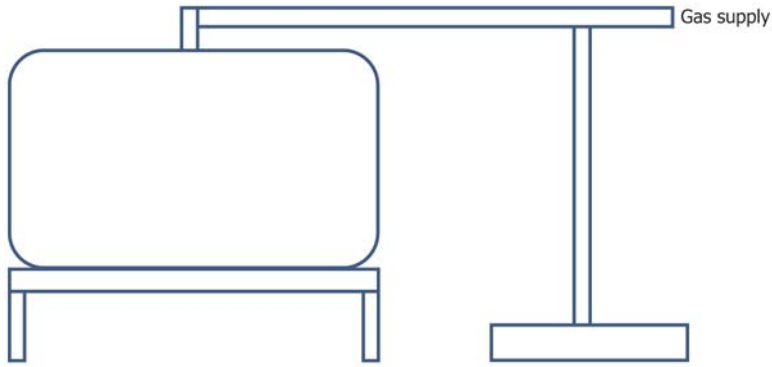

FIG. 6 Top Burner Placement - Rear View

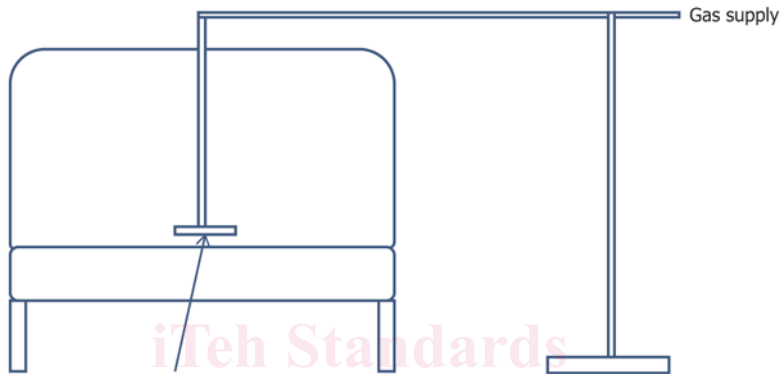
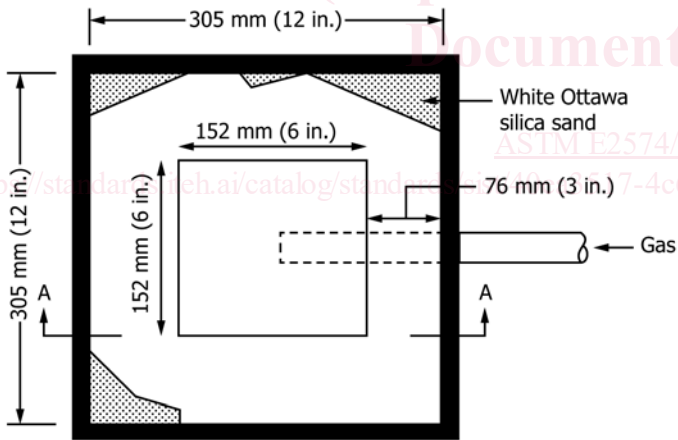
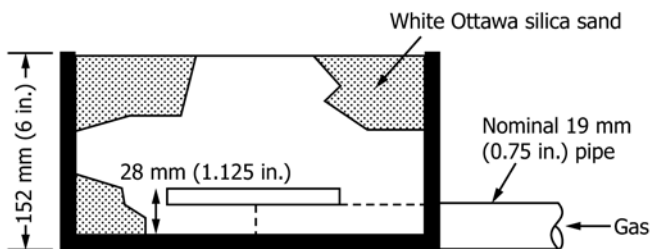

FIG. 7 Top Burner Placement - Front View



TOP VIEW



SIDE VIEW A-A

FIG. 8 Ignition Burner for Use Under Seat

assembly or (b) weighing each component separately and calculating the total weight by summing the weight of each of the combustible and non-combustible components.

10. Preparation of Apparatus

10.1 Prior to running each trial, ensure that the test chamber is clean and free of debris.

11. Conditioning

11.1 Condition specimens to equilibrium (constant weight) at an ambient temperature of $23 \pm 3^\circ\text{C}$ [$73 \pm 5^\circ\text{F}$] and a relative humidity of $50 \pm 5\%$ for a period of 24 h prior to the test.

12. Procedure

12.1 Install three rows of seats in the test chamber. The spacing between seat rows shall be the minimum spacing recommended by the installer or the spacing required by FMVSS 222. The exact spacing between rows shall be reported.

12.2 Seats shall be perpendicular to the dimension indicated as "length" in Fig. 1.

12.3 Install seats so that seat frames will not fall during the test.

12.4 Seat width shall be determined so that a maximum passenger capacity per row (2 seats) for the seat style is tested.

12.5 A complete test shall consist of two trials.

9.4 Record the weight of the fully-assembled seat. This shall be done in one of two ways: (a) weighing the complete seat

12.6 The first trial shall consist of the application of the ignition source in 7.1 at the ignition position on top of the seat assembly. After each trial, the test chamber shall be evacuated and the debris shall be removed before the next trial is performed.

12.7 The first trial shall consist of the application of the ignition source in 7.1 at the ignition position on top of the seat assembly.

12.7.1 Position the burner at the center of the seat assembly, 50 ± 5 mm [2 ± 0.2 in.] away from the seat assembly back and 25 ± 5 mm [1 ± 0.2 in.] above the seating surface.

12.7.2 The widest seat in the center row shall be tested.

12.8 The second trial shall consist of the application of the ignition source in 7.2 at the ignition position beneath the seat assembly.

12.8.1 Position the burner on the floor under the seat, centered on width so that the gas burner flame is directed towards the seat upholstery and not towards a metal frame.

12.8.2 The widest seat in the center row shall be tested.

12.9 Ignite the gas burner.

12.10 The test period shall begin once the ignition source has been ignited and end once all flaming of the specimen has ceased, including any flaming of the specimen at the ignition source, unless safety considerations dictate an earlier termination.

12.11 A new set of seats shall be used for each trial.

12.12 After the completion of each trial, weigh the entire seat assembly, excluding any loose material which has fallen off the seat onto the floor.

12.13 After the completion of each trial, the test chamber shall be evacuated and the debris shall be removed before the next trial is performed.

13. Report

13.1 For each trial, report the information required in 13.2 through 13.6.

13.2 Detailed description of the seat assembly being tested, including the weights and how those weights were determined.

13.3 Detailed description of the actual test layout, including seat spacing and test chamber dimensions.

13.4 Time elapsed between ignition and cessation of flaming (in s).

13.5 The mass loss of the seat upholstery (difference between the total assembly mass before and after the test) (in g).

13.6 Whether flame has spread from the seat with the ignition source to adjacent seats or adjacent surfaces.

13.7 Whether melting of the seat materials has occurred and whether it has resulted in flaming drips beneath the seat.

14. Precision and Bias

14.1 The precision and bias of this test method has not yet been established.

14.2 Precision and bias information is available for Test Method E1537 and for Test Method E2257.

15. Keywords

15.1 bus; fire test; flame spread; gas burner; paper bag; school bus; transportation

[ASTM E2574/E2574M-17](https://standards.iteh.ai/catalog/standards/sist/40ea3517-4d-b351-69f5d239d1d7/astm-e2574-e2574m-17)

<https://standards.iteh.ai/catalog/standards/sist/40ea3517-4d-b351-69f5d239d1d7/astm-e2574-e2574m-17> ANNEX

(Mandatory Information)

A1. OPTIONAL HEAT RELEASE MEASUREMENTS

A1.1 If optional heat release measurements are to be conducted, they shall be conducted in accordance with the requirements of Practice E2067.