



Designation: ~~D1298~~—~~12b~~ **D1298 – 12b (Reapproved 2017)**



Manual of Petroleum Measurement Standards (MPMS), Chapter 9.1

Standard Test Method for Density, Relative Density, or API Gravity of Crude Petroleum and Liquid Petroleum Products by Hydrometer Method¹

This standard is issued under the fixed designation D1298; the number immediately following the designation indicates the year of original adoption or, in the case of revision, the year of last revision. A number in parentheses indicates the year of last reapproval. A superscript epsilon (ϵ) indicates an editorial change since the last revision or reapproval.

This standard has been approved for use by agencies of the U.S. Department of Defense.

1. Scope*~~Scope~~

1.1 This test method covers the laboratory determination using a glass hydrometer in conjunction with a series of calculations, of the density, relative density, or API gravity of crude petroleum, petroleum products, or mixtures of petroleum and nonpetroleum products normally handled as liquids, and having a Reid vapor pressure of ~~101.325 kPa (14.696 psi)~~ 101.325 kPa (14.696 psi) or less. Values are determined at existing temperatures and corrected to ~~15°C~~ 15 °C or ~~60°F~~ 60 °F by means of a series of calculations and international standard tables.

1.2 The initial hydrometer readings obtained are uncorrected hydrometer readings and not density measurements. Readings are measured on a hydrometer at either the reference temperature or at another convenient temperature, and readings are corrected for the meniscus effect, the thermal glass expansion effect, ~~alternate~~ alternative calibration temperature effects and to the reference temperature by means of the Petroleum Measurement Tables; values obtained at other than the reference temperature being hydrometer readings and not density measurements.

1.3 Readings determined as density, relative density, or API gravity can be converted to equivalent values in the other units or ~~alternate~~ alternative reference temperatures by means of Interconversion Procedures (API MPMS Chapter 11.5), or Adjunct to **D1250** Guide for Petroleum Measurement Tables (API MPMS Chapter 11.1), or both, or tables, as applicable.

1.4 The initial hydrometer readings determined in the laboratory shall be recorded before performing any calculations. The calculations required in Section 10 shall be applied to the initial hydrometer reading with observations and results reported as required by Section 11 prior to use in a subsequent calculation procedure (ticket calculation, meter factor calculation, or base prover volume determination).

1.5 **Annex A1** contains a procedure for verifying or certifying the equipment for this test method.

1.6 The values stated in SI units are to be regarded as standard. ~~The values given in parentheses are provided for information only.~~

1.6.1 Exception—The values given in parentheses are provided for information only.

1.7 *This standard does not purport to address all of the safety concerns, if any, associated with its use. It is the responsibility of the user of this standard to establish appropriate safety and health practices and determine the applicability of regulatory limitations prior to use.*

1.8 *This international standard was developed in accordance with internationally recognized principles on standardization established in the Decision on Principles for the Development of International Standards, Guides and Recommendations issued by the World Trade Organization Technical Barriers to Trade (TBT) Committee.*

2. Referenced Documents

2.1 *ASTM Standards:*²

D1250 Guide for Use of the Petroleum Measurement Tables

¹ This test method is under the jurisdiction of ASTM Committee **D02** on Petroleum Products, Liquid Fuels, and Lubricants and the API Committee on Petroleum Measurement, and is the direct responsibility of Subcommittee **D02.02** /COMQ, the joint ASTM-API Committee on Hydrocarbon Measurement for Custody Transfer (Joint ASTM-API). This test method has been approved by the sponsoring committees and accepted by the Cooperating Societies in accordance with established procedures.

Current edition approved ~~June 1, 2012~~ July 15, 2017. Published ~~October 2012~~ July 2017. Originally approved in 1953. Last previous edition approved in 2012 as **D1298D1298 – 12b – 12a**. DOI: ~~10.1520/D1298-12B-10.1520/D1298-12BR17~~.

² For referenced ASTM standards, visit the ASTM website, www.astm.org, or contact ASTM Customer Service at service@astm.org. For *Annual Book of ASTM Standards* volume information, refer to the standard's Document Summary page on the ASTM website.

*A Summary of Changes section appears at the end of this standard

D4057 Practice for Manual Sampling of Petroleum and Petroleum Products
 D4177 Practice for Automatic Sampling of Petroleum and Petroleum Products
 D5854 Practice for Mixing and Handling of Liquid Samples of Petroleum and Petroleum Products
 E1 Specification for ASTM Liquid-in-Glass Thermometers
 E100 Specification for ASTM Hydrometers

2.2 *API Standards:*³

MPMS Chapter 8.1 Manual Sampling of Petroleum and Petroleum Products (ASTM Practice D4057)
 MPMS Chapter 8.2 Automatic Sampling of Petroleum and Petroleum Products (ASTM Practice D4177)
 MPMS Chapter 8.3 Mixing and Handling of Liquid Samples of Petroleum and Petroleum Products (ASTM Practice D5854)
 MPMS Chapter 11.1 Temperature and Pressure Volume Correction Factors for Generalized Crude Oils, Refined Products and Lubricating Oils (Adjunct to ASTM D1250)
 MPMS Chapter 11.5 Density/Weight/Volume Intraconversion

2.3 *Energy Institute Standards:*⁴

IP 389 Determination of wax appearance temperature (WAT) of middle distillate fuels by differential thermal analysis (DTA) or differential scanning calorimetry (DSC)
 IP Standard Methods Book, Appendix A, Specifications – IP Standard Thermometers

2.4 *ISO Standards:*⁵

ISO 649-1 Laboratory glassware – Density hydrometers for general purpose – Part 1: Specification

2.5 *ASTM Adjuncts:*

Adjunct to D1250 Guide for Petroleum Measurement Tables (API MPMS Chapter 11.1)⁶

3. Terminology

3.1 *Definitions of Terms Specific to This Standard:*

3.1.1 *API gravity, n*—a special function of relative density (specific gravity) $60/60^{\circ}\text{F}$, represented by:

$$^{\circ}\text{API} = [141.5 / (\text{relative density } 60/60^{\circ}\text{F})] - 131.5 \quad (1)$$

³ Published as Manual of Petroleum Measurement Standards. Available from the American Petroleum Institute (API), 1220 L St., NW, Washington, DC 20005-20005-4070, <http://www.api.org>.

⁴ Available from Energy Institute, 61 New Cavendish St., London, W1M 8AR, UK-W1G 7AR, U.K., <http://www.energyinst.org>.

⁵ Available from American National Standards Institute (ANSI), 25 W. 43rd St., 4th Floor, New York, NY 10036-10036, <http://www.ansi.org>.

⁶ Available from ASTM International Headquarters. Order Adjunct No. ADJD1250. Original adjunct produced in 1983.

3.1.1.1 *Discussion*—

No statement of reference temperature is required, as 60°F is included in the definition.

3.1.2 *cloud point, n*—temperature at which a cloud of wax crystals first appears in a liquid when it is cooled under specific conditions.

3.1.3 *density, n*—the mass of liquid per unit volume at 15°C and 101.325 kPa with the standard unit of measurement being kilograms per cubic metre.

3.1.3.1 *Discussion*—

Other reference temperatures, such as 20°C , may be used for some products or in some locations. Less preferred units of measurement (for example, kg/L or g/mL) are still in use.

3.1.4 *hydrometer reading, n*—the point on the hydrometer scale at which the surface of the liquid cuts the scale.

3.1.4.1 *Discussion*—

In practice for transparent fluids this can be readily determined by aligning the surface of the liquid on both sides of the hydrometer and reading the Hydrometer scale where these surface readings cut the scale (Hydrometer Reading – Observed). For nontransparent fluids the point at which the liquid surface cuts the Hydrometer scale cannot be determined directly and requires a correction (Meniscus Correction). The value represented by the point (Meniscus Reading) at which the liquid sample rises above the main surface of the liquid subtracted from the value represented by where the main surface of the liquid cuts the Hydrometer scale is the amount of the correction or Meniscus correction. This meniscus correction is documented and then subtracted from the value represented by the Meniscus Reading to yield the Hydrometer Reading corrected for the Meniscus (Hydrometer Reading – Observed, Meniscus Corrected).

3.1.5 *observed values, n*—values observed at temperatures other than the specified reference temperature. These values are only hydrometer readings and not density, relative density (specific gravity), or API gravity at that other temperature.

3.1.6 *pour point, n*—lowest temperature at which a test portion of crude petroleum or petroleum product will continue to flow when it is cooled under specified conditions.

3.1.7 *relative density (specific gravity), n*—the ratio of the mass of a given volume of liquid at a specific temperature to the mass of an equal volume of pure water at the same or different temperature. Both reference temperatures shall be explicitly stated.

3.1.7.1 Discussion—

Common reference temperatures include 60/60°F, 20/20°C, 60/60 °F, 20 –20/4°C, 20 °C, 20/4 °C. The historic deprecated term *specific gravity* may still be found.

3.1.8 *wax appearance temperature (WAT), n*—temperature at which waxy solids form when a crude petroleum or petroleum product is cooled under specified conditions.

4. Summary of Test Method

4.1 The sample is brought to a specified temperature and a test portion is transferred to a hydrometer cylinder that has been brought to approximately the same temperature. The appropriate hydrometer and thermometer, also at a similar temperature, are lowered into the test portion and allowed to settle. After temperature equilibrium has been reached, the hydrometer scale is read, and the temperature of the test portion is taken. The observed hydrometer reading is corrected for the meniscus effect, the thermal glass expansion effect, ~~alternate~~alternative calibration temperature effects and then reduced to the reference temperature by means of the volume correction factors or tables as applicable by use of the appropriate Adjunct to **D1250** Guide for Petroleum Measurement Tables (API *MPMS* Chapter 11.1) and observed temperature from the thermometer.

4.2 If necessary, the hydrometer cylinder and its contents are placed in a constant temperature bath to avoid excessive temperature variation during the test.

5. Significance and Use

5.1 Accurate determination of the density, relative density (specific gravity), or API gravity of petroleum and its products is necessary for the conversion of measured volumes to volumes or masses, or both, at the standard reference temperatures of 15°C/15 °C or 60°F/60 °F during custody transfer.

5.2 This procedure is most suitable for determining the density, relative density (specific gravity), or API gravity of low viscosity transparent liquids. This procedure can also be used for viscous liquids by allowing sufficient time for the hydrometer to reach temperature equilibrium, and for opaque liquids by employing a suitable meniscus correction. Additionally for both transparent and opaque fluids the readings shall be corrected for the thermal glass expansion effect and ~~alternate~~alternative calibration temperature effects before correcting to the reference temperature.

5.3 When used in connection with bulk oil measurements, volume correction errors are minimized by observing the hydrometer reading at a temperature close to that of the bulk oil temperature.

5.4 Density, relative density, or API gravity is a factor governing the quality and pricing of crude petroleum. However, this property of petroleum is an uncertain indication of its quality unless correlated with other properties.

5.5 Density is an important quality indicator for automotive, aviation and marine fuels, where it affects storage, handling and combustion.

6. Apparatus

6.1 *Hydrometers*, of glass, graduated in units of density, relative density, or API gravity as required, conforming to Specification **E100** or ISO 649-1, and the requirements given in **Table 1**.

6.1.1 The user should ascertain that the instruments used for this procedure conform to the requirements set out above with respect to materials, dimensions, and scale errors. In cases where the instrument is provided with a calibration certificate issued by a recognized standardizing body, the instrument is classed as certified and the appropriate corrections for the meniscus effect, the thermal glass expansion effect, and alternative calibration temperature effects shall be applied to the observed readings prior to corrections. Instruments that satisfy the requirements of this test method, but are not provided with a recognized calibration certificate, are classed as uncertified.

6.2 *Thermometers*, having range, graduation intervals and maximum permitted scale error shown in **Table 2** and conforming to Specification **E1** or IP Appendix A.

6.2.1 ~~Alternate~~Alternative measuring devices or systems may be used, provided that the total uncertainty of the calibrated system is no greater than that specified in **6.2**. The stated repeatability and reproducibility values are not applicable if ~~alternate~~alternative fluids are used in the liquid-in-glass thermometers.

TABLE 1 Recommended Hydrometers

Units	Range		Scale ^A		Meniscus
	Total	Each Unit	Interval ^A	Error ^A	
Density, kg/m ³ at 15°C	600–1100	20	0.2	±0.2	+0.3
	600–1100	50	0.5	±0.3	+0.7
	600–1100	50	1.0	±0.6	+1.4
Density, kg/m ³ at 15 °C	600 - 1100	20	0.2	± 0.2	+0.3
	600 - 1100	50	0.5	± 0.3	+0.7
	600 - 1100	50	1.0	± 0.6	+1.4
Relative density, 60/60°F	0.600–1.100	0.020	0.0002	±0.0002	+0.0003
	0.600–1.100	0.050	0.0005	±0.0003	+0.0007
	0.600–1.100	0.050	0.001	±0.0006	+0.0014
Relative density, 60/60 °F	0.600 - 1.100	0.020	0.0002	± 0.0002	+0.0003
	0.600 - 1.100	0.050	0.0005	± 0.0003	+0.0007
	0.600 - 1.100	0.050	0.001	± 0.0006	+0.0014
Relative density, 60/60°F	0.650–1.100	0.050	0.0005	±0.0005	+0.0007
Relative density, 60/60 °F	0.650 - 1.100	0.050	0.0005	±0.0005	+0.0007
API Gravity	-1 - +101	12	0.1	± 0.1	-0.1

^AInterval and Error relate to Scale.

TABLE 2 Recommended Thermometers

Scale	Range	Graduation Interval	Scale Error
°C	-1 – +38	0.1	±0.1
°C	-20 – +102	0.2	±0.15
°F	-5 – +215	0.5	±0.25

TABLE 2 Recommended Thermometers

Scale	Range	Graduation Interval	Scale Error
°C	-1 – +38	0.1	± 0.1
°C	-20 – +102	0.2	± 0.15
°F	-5 – +215	0.5	± 0.25

6.3 *Hydrometer Cylinder*, clear glass, or plastic (see 6.3.1). The inside diameter of the cylinder shall be at least ~~25 mm~~ 25 mm greater than the outside diameter of the hydrometer and the height shall be such that the appropriate hydrometer floats in the sample test portion with at least ~~25 mm~~ 25 mm clearance between the bottom of the hydrometer and the bottom of the cylinder.

6.3.1 Hydrometer cylinders constructed of plastic materials shall be resistant to discoloration or attack by oil samples and shall not affect the material being tested. They shall not become opaque under prolonged exposure to sunlight.

6.4 *Constant-Temperature Bath*, if required, of dimensions such that it can accommodate the hydrometer cylinder with the test portion fully immersed below the test portion liquid surface, and a temperature control system capable of maintaining the bath temperature within ~~0.25°C~~ 0.25 °C of the test temperature throughout the duration of the test.

6.5 *Stirring Rod*, optional, of glass or plastic, approximately ~~400 mm~~ 400 mm in length.

7. Sampling

7.1 Unless otherwise specified, samples of non-volatile petroleum and petroleum products shall be taken by the procedures described in Practice **D4057** (API *MPMS* Chapter 8.1) and **D4177** (API *MPMS* Chapter 8.2).

7.2 Samples of volatile crude petroleum or petroleum products are preferably taken by Practice **D4177** (API *MPMS* Chapter 8.2), using a variable volume (floating piston) sample receiver to minimize any loss of light components which may affect the accuracy of the density measurement. In the absence of this facility, extreme care shall be taken to minimize these losses, including the transfer of the sample to a chilled container immediately after sampling.

7.3 *Sample Mixing*—May be necessary to obtain a test portion representative of the bulk sample to be tested, but precautions shall be taken to maintain the integrity of the sample during this operation. Mixing of volatile crude petroleum or petroleum products containing water or sediments, or both, or the heating of waxy volatile crude petroleum or petroleum products may result in the loss of light components. The following subsections (7.3.1 to 7.3.4) will give some guidance on sample integrity maintenance.

7.3.1 *Volatile Crude Petroleum and Petroleum Products Having an RVP Greater than 50 kPa*—Mix the sample in its original closed container in order to minimize the loss of light components.

NOTE 1—Mixing volatile samples in open containers will lead to loss of light components and consequently affect the value of the density obtained.

7.3.2 *Waxy Crude Petroleum*—If the petroleum has an expected pour point above ~~10°C~~ 10 °C, or a cloud point or WAT above ~~15°C~~ 15 °C, warm the sample to a temperature that is sufficient for ensuring the material is fluid enough to provide adequate mixing

without excessively heating the material that would otherwise compromise the integrity of the sample. Samples heated to 9°C above its pour point, or 3°C above its cloud point or WAT have been found to be suitable temperatures to warm samples prior to mixing. Whenever possible, mix the sample in its original closed container in order to minimize the loss of light components.

7.3.3 *Waxy Distillate*—Warm the sample to a temperature that is sufficient for ensuring the material is fluid enough to provide adequate mixing without excessively heating the material that would otherwise compromise the integrity of the sample. Samples heated to 3°C above its cloud point or WAT have been found to be suitable temperatures to warm samples prior to mixing.

7.3.4 *Residual Fuel Oils*—Heat the sample to the test temperature prior to mixing (see 9.1.1 and Note 4).

7.4 Additional information on the mixing and handling of liquid samples will be found in Practice D5854 (API MPMS Chapter 8.3).

8. Apparatus Verification or Certification

8.1 Hydrometers and thermometers shall be verified in accordance with the procedures in Annex A1.

9. Procedure

9.1 Temperature of Test:

9.1.1 Bring the sample to the test temperature which shall be such that the sample is sufficiently fluid but not so high as to cause the loss of light components, nor so low as to result in the appearance of waxy solids in the test portion.

NOTE 2—The density, relative density or API gravity determined by the hydrometer is most accurate at or near the reference temperature.

NOTE 3—The volume and density, the relative density, and the API corrections in the volume correction tables are based on the average expansions of a number of typical materials. Since the same coefficients were used in compiling each set of tables, corrections made over the same temperature interval minimize errors arising from possible differences between the coefficient of the material under test and the standard coefficients. This effect becomes more important as temperatures diverge from the reference temperature.

NOTE 4—The hydrometer reading is obtained at a temperature appropriate to the physico-chemical characteristics of the material under test. This temperature is preferably close to the reference temperature, or when the value is used in conjunction with bulk oil measurements, within 3°C of the bulk temperature (see 5.3).

9.1.2 For crude petroleum, bring the sample close to the reference temperature or, if wax is present, to 9°C above its expected pour point or 3°C above its expected cloud point or WAT, whichever is higher.

NOTE 5—For crude petroleum an indication of the WAT can be found using IP 389, with the modification of using $50\ \mu\text{L} \pm 5\ \mu\text{L}$ of sample. The precision of WAT for crude petroleum using this technique has not been determined.

9.2 Density Measurement:

9.2.1 Bring the hydrometer cylinder and thermometer to within approximately 5°C of the test temperature.

9.2.2 Transfer the sample to the clean, temperature-stabilized hydrometer cylinder without splashing, to avoid the formation of air bubbles, and minimize evaporation of the lower boiling constituents of more volatile samples. (**Warning**—Extremely flammable. Vapors may cause flash fire!)

9.2.3 Transfer highly volatile samples by siphoning or water displacement. (**Warning**—Do not siphon by mouth as it could result in ingestion of sample!)

9.2.3.1 Samples containing alcohol or other water-soluble materials should be placed into the cylinder by siphoning.

9.2.4 Remove any air bubbles formed after they have collected on the surface of the test portion, by touching them with a piece of clean filter paper or other suitable means before inserting the hydrometer.

9.2.5 Place the cylinder containing the test portion in a vertical position in a location free from air currents and where the temperature of the surrounding medium does not change more than 2°C during the time taken to complete the test. When the temperature of the test portion differs by more than 2°C from ambient, use a constant temperature bath to maintain an even temperature throughout the test duration.

9.2.6 Insert the appropriate thermometer or temperature measurement device and stir the test portion with a stirring rod, using a combination of vertical and rotational motions to ensure uniform temperature and density throughout the hydrometer cylinder. Record the temperature of the sample to the nearest 0.1°C and remove the thermometer/temperature measuring device and stirring rod from the hydrometer cylinder.

NOTE 6—If a liquid-in-glass thermometer is used, this is commonly used as the stirring rod.

9.2.7 Lower the appropriate hydrometer into the liquid and release when in a position of equilibrium, taking care to avoid wetting the stem above the level at which it floats freely. For low viscosity transparent or translucent liquids observe the meniscus shape when the hydrometer is pressed below the point of equilibrium about $1\ \text{mm}$ to $2\ \text{mm}$ and allowed to return to equilibrium. If the meniscus changes, clean the hydrometer stem and repeat until the meniscus shape remains constant.

9.2.8 For opaque viscous liquids, allow the hydrometer to settle slowly into the liquid.

9.2.9 For low viscosity transparent or translucent liquids depress the hydrometer about two scale divisions into the liquid, and then release it, imparting a slight spin to the hydrometer on release to assist in bringing it to rest floating freely from the walls of the hydrometer cylinder. Ensure that the remainder of the hydrometer stem, which is above the liquid level, is not wetted as liquid on the stem affects the reading obtained.

9.2.10 Allow sufficient time for the hydrometer to come to rest, and for all air bubbles to come to the surface. Remove any air bubbles before taking a reading (see 9.2.12).

9.2.11 If the hydrometer cylinder is made of plastic, dissipate any static charges by wiping the outside with a damp cloth. (Static charges often build up on plastic cylinders and may prevent the hydrometer from floating freely.)

9.2.12 When the hydrometer has come to rest floating freely away from the walls of the cylinder, read the hydrometer scale reading to the nearest one-fifth or one-tenth of a full scale division depending upon the number of subdivisions (that is, 5 or 10, respectively) that exist between a full scale division in accordance with 9.2.12.1 or 9.2.12.2.

9.2.12.1 For transparent liquids, record the hydrometer reading as the point on the hydrometer scale at which the principal surface of the liquid cuts the scale by placing the eye slightly below the level of the liquid and slowly raising it until the surface, first seen as a distorted ellipse, appears to become a straight line cutting the hydrometer scale (see Fig. 1).

9.2.12.2 For opaque liquids record the hydrometer reading at the point on the hydrometer scale to which the sample rises above its main surface, by observing with the eye slightly above the plane of the surface of the liquid (see Fig. 2). This reading requires a meniscus correction. This correction can be determined by one of two methods: 1) observe the height above the main surface of the liquid to which the sample rises on the hydrometer scale when the hydrometer in question is immersed in a transparent liquid having a surface tension similar to that of a sample under test; 2) use the nominal values shown in Table 1. Document this value as the Meniscus correction.

NOTE 7—When testing opaque liquids using a metal hydrometer cylinder, accurate readings of the hydrometer scale can only be ensured if the liquid surface is within 5 mm (5 mm) of the top of the cylinder.

9.2.13 Immediately after recording the hydrometer scale reading, carefully lift the hydrometer out of the liquid, insert the thermometer or temperature measurement device and stir the test portion vertically with the stirring rod. Record the temperature of the test portion to the nearest 0.1°C (0.1 °C). If this temperature differs from the previous reading (9.2.6) by more than 0.05°C (0.05 °C), repeat the hydrometer observations and thermometer observations until the temperature becomes stable within 0.05°C (0.05 °C). If a stable temperature cannot be obtained, place the hydrometer cylinder in a constant temperature bath and repeat the procedure from 9.1.

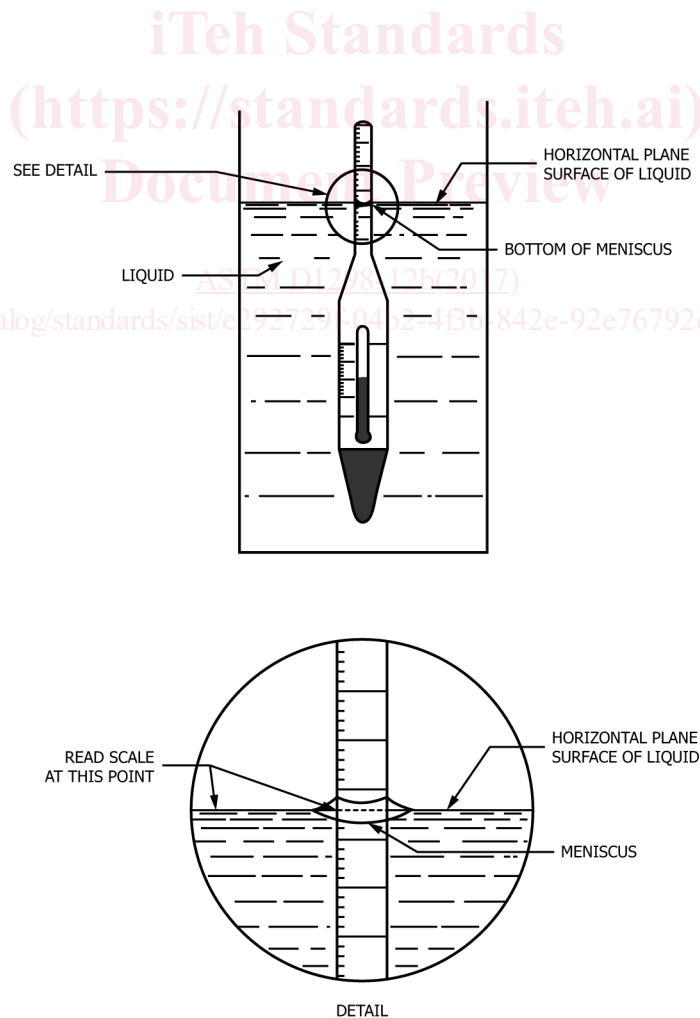

FIG. 1 Hydrometer Scale Reading for Transparent Liquids