



Designation: F2375 – 09 (Reapproved 2017)

Standard Practice for Design, Manufacture, Installation and Testing of Climbing Nets and Netting/Mesh used in Amusement Rides, Devices, Play Areas and Attractions¹

This standard is issued under the fixed designation F2375; the number immediately following the designation indicates the year of original adoption or, in the case of revision, the year of last revision. A number in parentheses indicates the year of last reapproval. A superscript epsilon (ϵ) indicates an editorial change since the last revision or reapproval.

1. Scope

1.1 This practice establishes performance specifications and performance standards for the design, manufacturing, and maintenance of netting and or mesh used in play areas and systems designed for interactive play activities within amusement attractions.

1.2 The range of users encompassed by this safety performance specification is 32 in. (0.81 m) (2 years old, 5th percentile) through 50 in. (1.27 m) (8 years old, 50th percentile), 50 in. (1.27 m) (8 years old, 50th percentile) through 64 in. (1.62 m) (12 years old 95th percentile), 32 in. (0.81 m) (2 years old, 5th percentile) through 64 in. (1.62 m) (12 years old, 95th percentile), and 64 in. (1.62 m) (12-year old, 95th percentile) through adult.

1.3 The ages listed in this standard are intended to be used as a guide for determining activities and use. The height requirements are the governing factor.

1.4 Home playground equipment, matrix nets, nets used as/or in fencing, sports equipment, fitness equipment, playground equipment covered by Consumer Safety Performance Specification F1487 and soft contained play equipment (SCPE) covered by Safety Performance Specification F1918 in areas not covered by F24 standards are not included in this standard.

1.5 This practice includes an appendix (non-mandatory), which provides additional information (for example, rationale, background, interpretations, drawings, commentary, and so forth.) to improve the user's understanding and application of the criteria presented in this practice. The appendix information shall not be interpreted as mandatory design criteria.

1.6 This standard is intended for new climb areas and major modifications.

1.7 Existing climb areas may qualify as compliant for five years following the date of this publication of this practice as

¹ This practice is under the jurisdiction of ASTM Committee F24 on Amusement Rides and Devices and is the direct responsibility of Subcommittee F24.10 on Test Methods.

Current edition approved May 1, 2017. Published July 2017. Originally approved in 2009. Last previous edition approved in 2009 as F2375 – 09. DOI: 10.1520/F2375-09R17.

long as any significant design related failures or significant design related safety issues have been mitigated. Thereafter, climb areas must qualify as “Service Proven” per Practice F2291 or meet the requirements of this practice.

1.8 The values stated in inch-pound units are to be regarded as standard. The values given in parentheses are mathematical conversions to SI units that are provided for information only and are not considered standard.

1.9 *This standard does not purport to address all of the safety concerns, if any, associated with its use. It is the responsibility of the user of this standard to establish appropriate safety, health, and environmental practices and determine the applicability of regulatory limitations prior to use.*

1.10 *This international standard was developed in accordance with internationally recognized principles on standardization established in the Decision on Principles for the Development of International Standards, Guides and Recommendations issued by the World Trade Organization Technical Barriers to Trade (TBT) Committee.*

2. Referenced Documents

2.1 *ASTM Standards:*²

F747 [Terminology Relating to Amusement Rides and Devices](#)

F770 [Practice for Ownership, Operation, Maintenance, and Inspection of Amusement Rides and Devices](#)

F853 [Practice for Maintenance Procedures for Amusement Rides and Devices \(Withdrawn 2014\)](#)³

F893 [Guide for Auditing Amusement Rides and Devices \(Withdrawn 2013\)](#)³

F1159 [Practice for Design of Amusement Rides and Devices that are Outside the Purview of Other F24 Design Standards](#)

F1193 [Practice for Quality, Manufacture, and Construction](#)

² For referenced ASTM standards, visit the ASTM website, www.astm.org, or contact ASTM Customer Service at service@astm.org. For *Annual Book of ASTM Standards* volume information, refer to the standard's Document Summary page on the ASTM website.

³ The last approved version of this historical standard is referenced on www.astm.org.

- of Amusement Rides and Devices
- F1292 Specification for Impact Attenuation of Surfacing Materials Within the Use Zone of Playground Equipment
- F1305 Guide for Classification of Amusement Ride and Device Related Injuries and Illnesses (Withdrawn 2011)³
- F1487 Consumer Safety Performance Specification for Playground Equipment for Public Use
- F1918 Safety Performance Specification for Soft Contained Play Equipment
- F2291 Practice for Design of Amusement Rides and Devices
- 2.2 *Other Standards:*
- ASSE/ANSI A10.11 Safety Requirements for Personnel and Debris Nets⁴
- CDC Growth Charts CDC Basic Body Measurements⁵
- CI 1500 Test Methods for Fiber Rope⁶
- NFPA 701 Standard Methods of Fire Tests for Flame Propagation of Textiles and Films⁷

3. Terminology

3.1 *Definitions of Terms Specific to This Standard:*

3.1.1 *safety net, n*—net that is intended to arrest a falling person.

4. Material and Manufacture

4.1 The manufacturer shall maintain a quality assurance program in conformance with Practice F1193.

4.2 *Hardware and Structures*—All metals, hardware and supports shall meet the requirements per Section 4 of Consumer Safety Performance Specification F1487.

4.3 *Climb Nets:*

4.3.1 Rope climb nets shall be manufactured from rope with a minimum diameter or width of 0.50 in. (13 mm) and breaking strength of 3000 lb (1361 kg), per CI 1500-01, sections 11.1 through 11.5.

4.3.2 Web climb nets shall be manufactured from webbing with a minimum width of 1.0 in. (25 mm) and breaking strength of 3000 lb (1361 kg).

4.3.3 All nodes shall be fixed and incapable of sliding along rope, web, or netting material.

4.3.4 The nodes shall be either be soft and flexible, or shall not extend more than 0.25 in. (6 mm) above the top net rope surface. Nodes shall meet the testing requirements in 7.6.

4.4 *Barrier Nets:*

4.4.1 The interior hole size of Class 1 barrier net or Class 2 barrier rated barrier net must be larger than 1.25 in. (32 mm), or meet the requirements of the prototype test procedure described in 7.4 for maximum hole size of no-hold netting and must meet the test requirements of 7.1, and the strength requirements of either the Class 1 barrier net requirements

described in 7.2, or the Class 2 barrier net requirements described in 7.3, as determined by use.

4.4.2 No-hold netting is allowed providing it meets the requirements in 7.5, and is not necessary for use as a handhold. Small mesh shall meet the Class 1 barrier net requirements described in 7.2 or the Class 2 barrier net requirements described in 7.3.

4.4.3 Two categories of barriers and standardized testing and rating of barriers is provided and are dependent on designed loads as specified by the design engineer of record for selection and use.

4.4.4 Barrier nets/mesh are vertical nets intended to prevent both inadvertent and deliberate attempts to pass through the device, or to contain persons within an area.

4.4.5 *Class 1 Barrier Nets/Mesh:*

4.4.5.1 Class 1 barrier nets/mesh are enclosures around an elevated surface that helps passively contain the users(s) within the bounded area, such as in soft contained play equipment, inflatable, or railings. Typically these are smaller paneled areas.

4.4.5.2 Class 1 barrier nets/mesh are allowed in more passive use areas, such as Soft Play units, additional security on railings, queue lines, etc.

4.4.6 *Class 2 Barrier Nets/Mesh:*

4.4.6.1 Class 2 barrier nets/mesh shall be used in interactive climbs where the barrier is a component of use. Examples are mazes, bridges, ramps etc. such as found in typical amusement park climbs, water parks, and zoo net areas.

4.4.6.2 Typically these are larger netted enclosures around elevated surfaces such as a cabled bridge, ramp etc.

4.4.7 In areas such as bridges where no-hold netting is desired, a higher rating may be accomplished by installing the no-hold netting inside the Class 2 rated barrier.

4.5 *Fire Retardant*—Barrier and debris netting used in indoor applications shall be fire retardant, and shall meet NFPA 701 method 2 (large scale test) for outdoor use unless a different standard is required by local, state, or federal law.

4.6 *No-Hold Netting*—Openings in the mesh of no-hold netting shall be designed to prevent entrapment of fingers or toes, or snaring of buttons normally used in children's clothing. Mesh openings shall meet the testing requirements in 7.4.

4.7 *Debris Net*—Debris netting shall be capable of catching items that, if dropped, may cause a hazard to users below, as determined by the owner/operator, and must meet the requirements in 7.2 or 7.3 as determined by the designer/engineer of record, and based on use.

4.8 *Safety Nets:*

4.8.1 Any net that is hung horizontally and is intended to, or may be required to, arrest a fall shall meet the requirements of ASSE/ANSI A10.11 and the test procedure described in 7.5.

4.8.2 The net mesh for safety nets shall be attached to a border rope with a minimum breaking strength of 5000 lb (2268 kg). The attached mesh shall be individually attached to the border rope in a manner that will prevent it from sliding or moving on the border rope. The fastening method shall meet or exceed the strength of the material the mesh is made of.

⁴ Available from American National Standards Institute (ANSI), 25 W. 43rd St., 4th Floor, New York, NY 10036, <http://www.ansi.org>.

⁵ Available from Centers for Disease Control & Prevention (CDC), 1600 Clifton Rd., Atlanta, GA 30333, <http://www.cdc.gov>.

⁶ Available from Cordage Institute, 994 Old Eagle School Road, Suite 1019, Wayne, PA 19087, <http://www.ropecord.com/>.

⁷ Available from National Fire Protection Association (NFPA), 1 Batterymarch Park, Quincy, MA 02169-7471, <http://www.nfpa.org>.

5. General Design and Manufacture Requirements

5.1 Netting represented as complying with this performance standard shall meet all applicable requirements specified herein. Anyone representing compliance with this specification shall keep such essential records as are necessary to document any claim that the requirements within this specification have been met.

5.2 Netting manufacturers shall include a certificate of compliance that the net's material meets the requirements of this standard. The certificate shall include: (1) Name of manufacturer, (2) Identification of net material, (3) Date manufactured, (4) Date of prototype test, (5) Designation of test method, (6) Name of the testing agency, and (7) Serial number or Batch number.

5.2.1 Safety, climb nets, and bordered barrier nets shall be permanently labeled with the information in 5.2.

5.3 Netted areas shall meet requirements per Practice F2291-05, Section 1, sub-sections 1.3, 1.4, 1.5; Section 2, all sub-sections; Section 3, sub-sections 3.1.5, 3.1.10, 3.1.13, 3.1.14, 3.1.16, 3.1.20, 3.1.22, 3.1.24, 3.1.25, 3.1.28; Section 5, sub-sections 5.1 through 5.1.1.2, 5.1.2 through 5.1.4, 5.2 through 5.2.1.1, 5.4 through 5.5.2; Section 6, sub-sections 6.1 through 6.1.2, 6.2.1, 6.6.1 through 6.6.2.1, 6.6.2.3 through 6.6.2.5, 6.6.3, 6.6.3.2 through 6.7; Section 8, all sub-sections; Section 13, sub-sections 13.2.11, 13.3, 13.3.2, 13.3.4 through 13.3.8, 13.3.10, 13.3.11, 13.3.16, 13.3.17; Section 14, all sub-sections; Section 15, all sub-sections; and Section 16, all sub-sections.

5.4 Netted areas shall meet requirements per Practice F2291-05 specific to the ride or device which may include but not be limited to: hydraulics, pneumatics, electrical.

6. Performance Requirements

6.1 *Foot, Arm, Head, and Neck Entrapment*—Netted areas shall be designed and constructed or assembled so that any accessible net opening shall meet the performance requirements per Consumer Safety Performance Specification F1487 and test requirements in 7.1, 7.4, or 7.7 of this standard, based on intended age range.

7. Test Procedures

7.1 *Climb Net or Barrier Net:*

7.1.1 *In Place Test Procedure*—Place the foot probe (Fig. A1.1) in the opening, tapered-end first, with the plane of its base parallel to the plane of the opening; rotate the probe to its most adverse orientation (that is, the major axis of the base of the probe parallel to the major axis of the opening); apply a force of 50 lb (23 kg.) to the probe to attempt to pass it through the opening. A climb or barrier net passes the test if the opening does not allow the foot probe (Fig. A1.1) to be inserted so deeply that the opening admits the base of the probe when it is rotated to any orientation about its own axis. A climb or barrier net fails the test if the opening allows full passage of the foot probe (Fig. A1.1).

7.1.2 Climb nets and barrier nets shall meet this standard during commission and throughout its life cycle.

7.1.2.1 Testing is assumed to be conducted without guests on the nets. Testing can be conducted with or without the weight of the person conducting the test, depending on access to the testing locations.

7.1.3 Backer nets shall not be used as part of the climbing surface to bring the climbing net into compliance with test requirements described in 7.1.1.

7.2 *Prototype Test for a Class 1 Barrier and No-hold Netting:*

7.2.1 Class 1 barrier net or no-hold net shall be prototype tested. The test shall consist of two drops of a test as described in 7.2.2 – 7.2.4. After the drops are completed, and the weight is removed there shall be no broken strands fraying of the mesh, knots, nodes, or damaged bars. The net manufacturer shall provide certification of this test and material compliance per 5.2.

7.2.2 A Class 1 barrier net or no-hold net shall be secured in a non-movable manner in a rigid frame 4 by 4 ft (1.22 by 1.22 m). The test frame shall provide a 4 by 4-ft (1.22 by 1.22-m) inside opening appropriate for hanging net. The net shall not contact any surface during the test.

7.2.3 When hung in accordance with 7.2.2, the net shall not sag more than 3 in. at its center before the first drop. The net edge shall be level. It is understood and acceptable for sag to be present after the first or second drop.

7.2.4 A 50-lb (23 kg) bag of sand, 24 ± 2 in. (0.61 m \pm 51 mm) in diameter and no more than 12 in. (0.30 m) high, shall be dropped into the net from a height of 8 ft (2.44 m) above the net surface at center point of the net.

7.3 *Prototype Test Procedure for a Class 2 Barrier Net:*

7.3.1 Class 2 barrier net shall be prototype tested. The test shall consist of two drops of a test as described in 7.3.2 – 7.3.4. After the drops are completed, and the weight is removed there shall be no broken strands fraying of the mesh, knots, nodes, or damaged bars. The net manufacturer shall provide certification of this test and material compliance per 5.2.

7.3.2 A Class 2 barrier net shall be secured by each mesh, in a non-movable manner in a rigid frame 4 by 4 ft (1.22 by 1.22 m). The test frame shall provide a 4 by 4-ft (1.22 by 1.22-m) inside opening appropriate for hanging the net. The net shall not contact any surface during the test.

7.3.3 When hung in accordance with 7.3.2, the net shall not sag more than 3 in. at its center before the first drop. The net edge shall be level. It is understood and acceptable for sag to be present after the first or second drop.

7.3.4 A 250-lb (113 kg) bag of sand, 24 ± 2 in. (0.61 m \pm 51 mm) in diameter and no more than 24 in. (0.61 m) high, shall be dropped into the net from a height of 8 ft (2.44 m) above the net surface at center point of the net.

7.4 *Prototype Test Procedure for Maximum Hole Size of No-Hold Netting:*

7.4.1 The hole entry resistance of the no-hold netting shall be such that it will prevent the user(s) fingers or toes from becoming inadvertently caught or entangled in the net. A mesh opening shall not admit a 0.37-in. (9.5-mm) diameter rod with full-radius tip, when tested in accordance with 7.4.2 and 7.4.3.

The manufacturer shall provide certification of this test and material compliance per 5.2.

7.4.2 The no-hold netting shall be secured in a rigid 10 by 10-in. (0.25 by 0.25 m) opening ± 0.50 in. (13 mm). The frame shall be elevated sufficiently to prevent the net, when hung, from contacting any surface below the net during the test.

7.4.3 Gradually apply a force of 10 lb (45 N) to the center most adverse location in the mesh hole. Apply the above force in 10 random locations. The net must not accept the test rod at any time.

7.5 *Prototype Test Procedure for a Safety Net:*

7.5.1 The safety net shall be prototype test. The test shall consist of three drops of a 350-lb test weight as described in 7.5.2 – 7.5.4. After the drops are completed, and the weight is removed there shall be no broken strands fraying of the mesh, knots, nuds, or damaged bars. The net manufacturer shall provide certification of this test and material compliance per 5.2 or 5.2.1.

7.5.2 A net shall be attached to the cables in the test frame (Fig. A1.5 and Fig. A1.6). The net shall not contact any surface during the test.

7.5.3 When hung in accordance with 7.5.2, the net shall not sag more than 3 ft at its center before the first drop (Fig. A1.6). It is understood and acceptable for additional sag to be present after the first, second, or third drop.

7.5.4 A 350-lb bag of sand, 24 ± 5 in. ($0.61 \text{ m} \pm 127 \text{ mm}$) in diameter and no more than 40 in. (1.02 m) high shall be dropped in to into the net from a height of 50 ft (15.24 m). The test weight shall be dropped one time in each of the three locations as shown in (Fig. A1.6). The order of the drop locations is not required, so long as one drop is done in each location.

7.6 *Test Procedure for Hard Nodes:*

7.6.1 In-place test procedure and manufacturer's test procedure for all nodes manufactured from hard materials shall be as follows:

7.6.2 When the top rope is held parallel with the left and right side of the hard node height gauge (Fig. A1.3) the net node shall not be higher than the 0.25 in. (6 mm) center section (Fig. A1.4).

7.7 *Test Procedures for Nets with Large Openings:*

7.7.1 *In Place Test Procedure*—Place the foot probe (Fig. A1.1) in the opening, tapered-end first, with the plane of its base parallel to the plane of the opening; rotate the probe to its most adverse orientation (that is, the major axis of the base of the probe parallel to the major axis of the opening); apply a force of 50 lb (23 kg) to the probe to attempt to pass it through the opening. A support net passes the test if: (1) the opening does not allow the foot probe (Fig. A1.1) to be inserted so deeply that the opening admits the base of the probe when it is rotated to any orientation about its own axis, or (2) the opening allows full passage of the foot probe (Fig. A1.1) and also allows full passage of the larger head probe (Fig. A1.2) to pass completely through.

8. Installation and Use

8.1 *Attachments:*

8.1.1 Attachment methods for attaching climb nets, barrier nets, backer nets, and debris nets to their supports such as cables, ropes, pipes, etc. shall meet or exceed the tested rating of the net's rope, webbing, or cord per 4.3.1 or 4.3.2, as they apply to the material being used.

8.1.2 The nets may be lashed, hung, woven or tied to the support member or together. The fastening method, lashing, and/or fastening devices must meet or exceed the strength of the material the net is made of per 4.3.1 or 4.3.2, as they apply to the material being used.

8.1.2.1 If the strength of the netting material being used exceeds the minimum strength as required per 4.3.1 or 4.3.2, the attaching material shall meet the minimum requirements per 4.3.1 or 4.3.2, or the higher minimum required per the responsible designer.

8.1.3 The method of installation must be such that a normal and expected failure mode will result in a safe condition. dependence on one point of attachment is avoided. Example: The side barrier is secured to a cable; in addition, the climb net is attached to the barrier, which is attached to an upper cable, thus creating a redundant load path.

8.1.4 If the climb net contacts the ground or any hard surface, the surface shall meet the requirement of Specification F1292.

8.1.5 Climb nets are recommended to attach flush to decks, platforms, and landings.

8.1.6 Flexible portions of a net climb, barrier or safety net shall not be placed adjacent to potential impact hazards such as glass windows, furniture, or unpadded supports/structures.

8.1.7 Protective roof nets should be installed so as to maintain visibility throughout the area, and in a manner or mesh size, or both, to discourage swinging or hanging from the netting.

8.1.8 Protective roof nets shall meet the minimum strength requirements described in 7.2, Class 1 Barrier, and hole size/strength requirements per 4.4.1 or 4.4.2.

8.1.9 The netting support, structure, frame, cables, and ropes shall be designed to discourage climbing.

8.1.10 When safety nets are required, they shall comply with ASSE/ANSI A10.11 standards, and 7.5 of this standard.

8.2 *Fasteners and Hardware:*

8.2.1 All fasteners used to construct climb, barrier and debris nets, support and attachments shall be manufactured in accordance with Consumer Safety Performance Specification F1487 and shall meet the requirements of Sections 4 and 8 of this standard.

8.2.2 Any fasteners or attachment points the user can come into contact with shall meet Safety Performance Specification F1918.

8.2.3 Tie wraps shall have a minimum load rating to meet the requirements of 8.1.1 and 8.1.2. If the tie-wrap tails are cut, they must be flush, and free of any sharp points or edges.

8.2.3.1 Tie wraps utilized in an exterior application shall be rated for exterior use.

8.2.4 All fasteners, connecting and covering devices shall be inherently corrosion resistant or be provided with a corrosion-resistant coating.

8.2.5 Support cables shall be protected from causing chafing on any net (for example, coated cable, unmovable attachment method).

8.2.6 Support cables shall not run through an extra loop or hole in the supports. Each cable shall be an independent assembly, or secured with a thimble or equal support at each attachment or support point.

8.2.7 Steel cable that is permanently affixed to a hanger assembly shall have bearing surfaces, such as thimbles, to avoid wear on the cable strands.

8.2.8 Steel cable ends should be inaccessible or capped. Cables and steel-cored ropes shall be protected to prevent fraying, loosening, unraveling, or excessive shifting of joints. No frayed or splayed ends of the cable shall be exposed to the user(s).

8.2.9 When installed in accordance with the manufacturer's instructions, fasteners, connecting devices, and covering devices shall be installed to minimize loosening, or not be removable without the use of tools. Lock washers, self-locking nuts, locking pins, or other locking means shall be provided for all nuts and bolts to protect them from detachment. Hardware in moving joints shall also be secured against unintentional loosening.

8.3 *Operational Performance:*

8.3.1 Netting material that can be stretched by a force of 50 lb (23 kg.) when applied with the foot probe (Fig. A1.1) shall not contact any unpadding hard objects.

8.3.2 Barrier nets shall pass the following test:

8.3.2.1 Apply 50 lb (23 kg) of load to the foot probe (Fig. A1.1) with the handle at a 45° angle 12 in. (0.30 m) above the climbing net surface (Fig. A1.7).

8.3.2.2 With the same force, slide the foot probe (Fig. A1.1) down towards the climb net/attachment (Fig. A1.8).

8.3.2.3 The barrier net passes if the width of the foot probe (Fig. A1.1) does not extend beyond the climb net attachment (Fig. A1.9 and Fig. A1.10).

8.3.2.4 The barrier net fails if the foot probe (Fig. A1.1) extends past the climb net/attachment (Fig. A1.11).

8.3.2.5 This requirement is designed to prevent the barrier from becoming a walking surface.

8.3.2.6 No test is required if the side barrier meets the climb nets requirements per 4.3 (Fig. A1.12).

8.3.3 Any vertical or horizontal rope or member installed inside the barrier or on top of the climbing net shall meet the test requirements of Consumer Safety Performance Specification F1487 Section 7.1.2.1, test procedures for completely bounded non-ridged openings.

8.3.4 Barrier nets shall extend up to a height of 48 in. (1.21 m) or greater.

8.3.5 Net doors, net walls, and net dividers are considered to be barriers and shall meet or exceed the requirements for Class 2 barrier nets found in 7.3.

8.3.6 There shall be no gap wider than 1.0 in. (25 mm) between a deck and the net connection.

8.3.7 There shall be no gap larger than 3.0 in. (76 mm) high that allows passage of the width of the foot probe between the net and landing surface (Fig. A1.13).

8.3.8 Any rope, cable, chain, or flexible elastic rope material longer than 7.0 in. (178 mm) shall be:

8.3.8.1 Fixed at both ends or incapable of creating an inside loop less than 5.0 in. (127 mm), or shall be incapable of creating an inside loop less than 29 in. (736.6 mm) when fully loaded.

8.3.9 Barrier mesh may be used as a hand hold for support.

9. Maintenance and Operations

9.1 *Manufacturer Responsibilities:*

9.1.1 Manufacturing requirements for this standard follow Practice F1193, with modifications and additions described in 9.1.2 and 9.1.3.

9.1.2 Manufacturer's maintenance instructions shall be supplied with netting and shall include, but not be limited to, the following (for repair or replacement the information may be limited to scope of work and material supplied):

9.1.2.1 Recommended assembly and disassembly techniques and procedures as deemed necessary by the manufacturer to accomplish installation, repairs and maintenance. These may include, but are not limited to, drawings, photos, descriptions, and directions.

9.1.2.2 Parts and components described and numbered for ordering purposes.

9.1.2.3 Description of the recommended inspection and maintenance procedures including frequency.

9.1.2.4 Description of maximum allowable wear.

9.1.2.5 Recommendations for replacement fasteners, torque requirements, and appropriate criteria regarding the use of fasteners. Existing hardware installation being reinstalled will revert back to the installation requirements of the original design or supplier.

9.1.2.6 Recommendations for solutions known to be compatible with the materials used in construction of the net.

9.1.2.7 Recommendations for a planned program of inspections and maintenance that may be used as guidance by the owner/operator in developing of an overall preventive maintenance plan.

9.1.3 Manufacturer's operation instructions shall be supplied with netting and shall include, but not be limited to, the following (information may be limited to scope of work and material supplied):

9.1.3.1 Description of the intended use of the netting element including function and operation of its major components.

9.1.3.2 Description of the recommended capacity in weight or number of persons (including per person maximum weight), or both, as applicable.

9.1.3.3 Restrictions relating to special conditions where applicable, such as chemicals in water areas, etc.

9.2 *Owner/Operator Responsibilities:*

9.2.1 Operations requirements for this standard follow Practice F770, with modifications and additions described in 9.2.2 – 9.2.4.

9.2.2 Based on the manufacturer's recommendations, each owner/operator shall implement a program of maintenance, testing, and inspection as specified in Practice F770, Practice F853, and Guide F893.

9.2.3 Each owner/operator shall have written operational procedures for the netting system based on manufacturer's recommendations, and shall provide appropriate training to operator/attendants as specified in Practice F770.

9.2.4 The owner/operator of climb nets, barrier nets, debris nets or safety nets shall maintain records of incidents and injuries as specified in Practice F770, and shall notify the

manufacturer of any serious injuries or incidents as specified in Practice F770 and Guide F893.

10. Keywords

10.1 backer net; barrier net; climb net; debris net; mesh; net; netting; node; no-hold netting; safety net; web net

ANNEX

(Mandatory Information)

A1. FIGURES

See Figs. A1.1-A1.13.

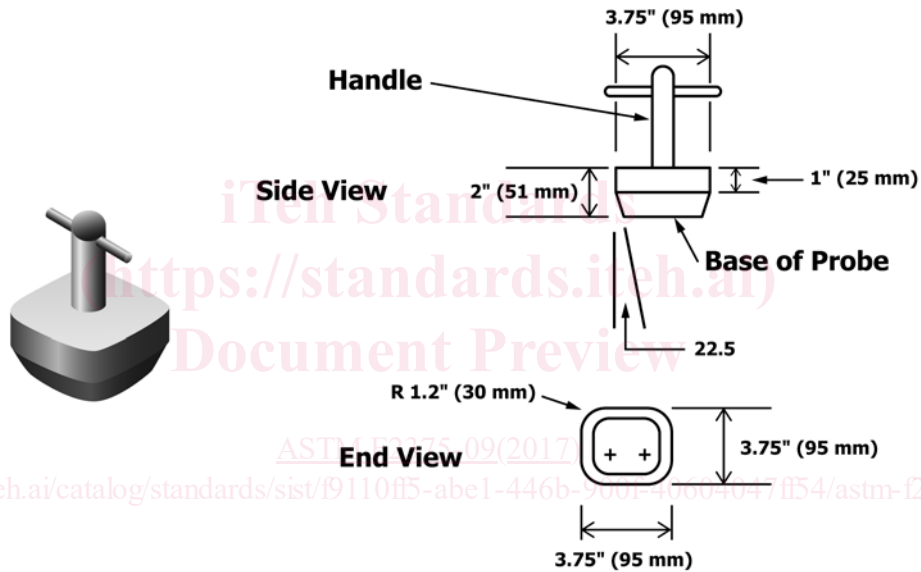

**NOTE: Any Ridged Material
FOOT PROBE**

NOTE 1—Reference paragraphs 7.1.1, 7.7.1, 8.3.1, 8.3.2.1, 8.3.2.2, 8.3.2.3, 8.3.2.4, X1.4, and X1.7.

FIG. A1.1 Foot Probe