



Designation: **E1754 – 17 E1754 – 17a**

## Standard Test Method for Determination of Low Levels of Water in Liquid Chlorine By Infrared Spectrophotometry<sup>1</sup>

This standard is issued under the fixed designation E1754; the number immediately following the designation indicates the year of original adoption or, in the case of revision, the year of last revision. A number in parentheses indicates the year of last reapproval. A superscript epsilon ( $\epsilon$ ) indicates an editorial change since the last revision or reapproval.

### 1. Scope\*

1.1 This test method covers the determination of the content of water in liquid chlorine in the concentration range of 0.5 to 15 mg/kg (ppm).

1.2 The values stated in SI units are to be regarded as standard. The values given in parentheses are for information only.

1.3 Review the current Safety Data Sheets (SDS) for detailed information concerning toxicity, first aid procedures, and safety precautions.

1.4 *This standard does not purport to address all of the safety concerns, if any, associated with its use. It is the responsibility of the user of this standard to establish appropriate safety and health practices and determine the applicability of regulatory limitations prior to use.* See Section 7 for specific hazards statements.

~~1.4 Review the current Safety Data Sheets (SDS) for detailed information concerning toxicity, first aid procedures, and safety precautions.~~

~~1.5 This international standard was developed in accordance with internationally recognized principles on standardization established in the Decision on Principles for the Development of International Standards, Guides and Recommendations issued by the World Trade Organization Technical Barriers to Trade (TBT) Committee.~~

### 2. Referenced Documents

2.1 *ASTM Standards:*<sup>2</sup>

[D1193 Specification for Reagent Water](#)

[D6809 Guide for Quality Control and Quality Assurance Procedures for Aromatic Hydrocarbons and Related Materials](#)

[E806 Test Method for Carbon Tetrachloride and Chloroform in Liquid Chlorine by Direct Injection \(Gas Chromatographic Procedure\)](#)

2.2 *Federal Standards:*<sup>3</sup> <https://standards.iteh.ai/catalog/standards/sist/e7ff7483-989c-4cd8-bb18-2b9b22027a72/astm-e1754-17a>

[49 CFR 173 Code of Federal Regulations Title 49 Transportation: Shippers' General Requirements for Shipments and Packaging, including Sections:](#)

[173.304 Charging of Cylinders with Liquefied Compressed Gas](#)

[173.314 Requirements for Compressed Gases in Tank Cars](#)

[173.315 Compressed Gases in Cargo Tanks and Portable Tank Containers](#)

### 3. Summary of Test Method

3.1 A sample of liquid chlorine is introduced into a special infrared cell and maintained as a liquid under its own pressure. A spectrometer scans from 400 to 4400 wavenumbers of the infrared transmission spectrum of liquid chlorine. This spectrum is then ratioed to one obtained of the nitrogen-filled infrared cell previously. The ratioed spectrum is converted to absorbance, and the net absorbance of the water band at 1596 wavenumbers, relative to a reference at 1663 wavenumbers, is determined. The amount of water corresponding to this net absorbance is determined from a calibration curve prepared from the infrared absorbances of standards that contain known concentrations of water in liquid chlorine.

<sup>1</sup> This test method is under the jurisdiction of ASTM Committee [D16](#) on [Aromatic Hydrocarbons-Aromatic, Industrial, Specialty and Related Chemicals](#) and is the direct responsibility of Subcommittee [D16.16](#) on Industrial and Specialty Product Standards.

Current edition approved [March 1, 2017](#) July 1, 2017. Published [March 2017](#) July 2017. Originally approved in 1995. Last previous edition approved in [2008](#) 2017 as E1754 – 08:17. DOI: [10.1520/E1754-17.10.1520/E1754-17a](#).

<sup>2</sup> For referenced ASTM standards, visit the ASTM website, [www.astm.org](http://www.astm.org), or contact ASTM Customer Service at [service@astm.org](mailto:service@astm.org). For *Annual Book of ASTM Standards* volume information, refer to the standard's Document Summary page on the ASTM website.

<sup>3</sup> Available from U.S. Government Printing Office, Superintendent of Documents, 732 N. Capitol St., NW, Washington, DC 20401-0001, <http://www.access.gpo.gov>.

\*A Summary of Changes section appears at the end of this standard

#### **4. Significance and Use**

4.1 Trace amounts of water may be detrimental to the use of chlorine in some applications. The amount of water in the chlorine must be known to prevent problems during its use.

**iTeh Standards**  
**(<https://standards.itih.ai>)**  
**Document Preview**

[ASTM E1754-17a](#)

<https://standards.itih.ai/catalog/standards/sist/e7ff7483-989c-4cd8-bb18-2b9b22027a72/astm-e1754-17a>



- 1/8" x 1/4"
- material: Hastalloy C
- 2 required

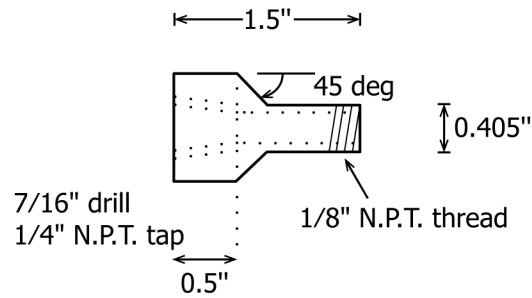
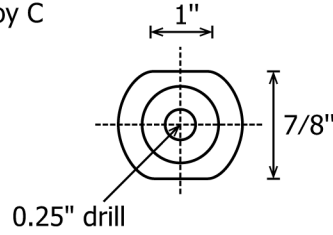

if desired, pipe adapters may be welded

FIG. 1(a) Pipe Adapter

(<https://standards.iteh.ai>)  
Document Preview

Hastalloy C  
1 required

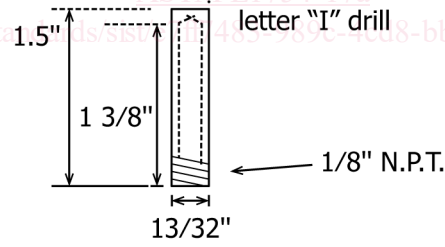

FIG. 1(b) Air Cap Detail

Letter "R" drill 7/16" deep

Letter "I" drill thru  
1/8" N.P.T. tap

3 holes as shown

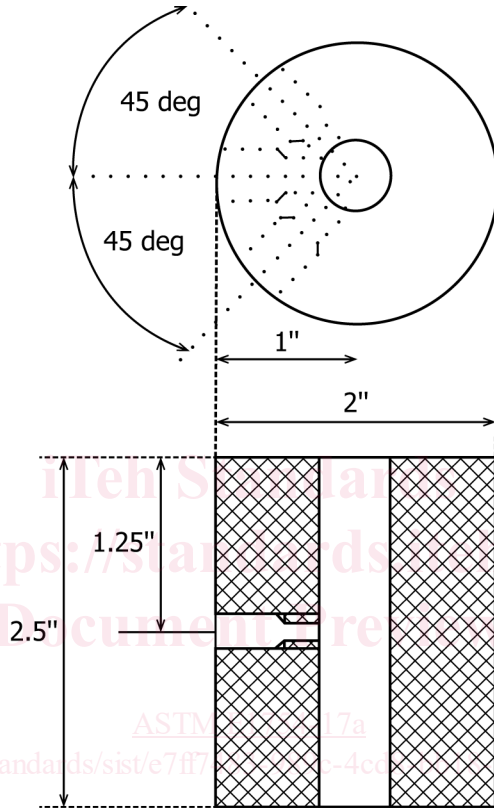
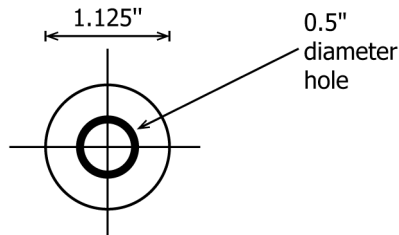

FIG. 1(c) Body Detail



DuPont Kalrez Perfluoroelastomer  
2 required  
material about 0.030" thick

FIG. 1(d) Gasket Detail

Material: Teflon  
2 required

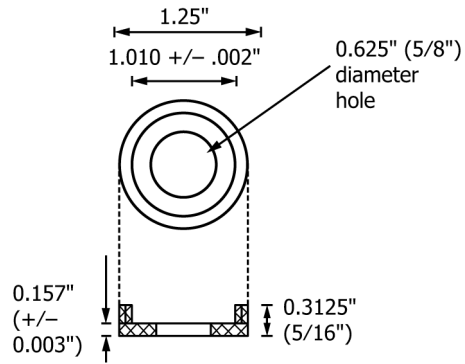

FIG. 1(e) Insert Detail

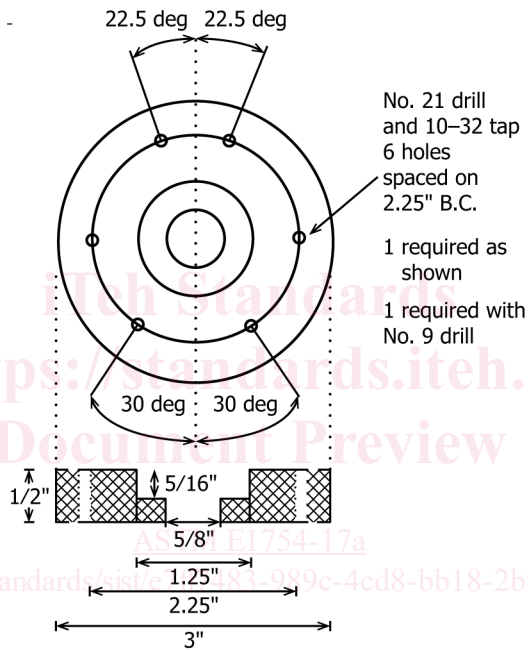

FIG. 1(f) Flange Detail