



# Standard Test Method for Oxidation Characteristics of Inhibited Mineral Oils<sup>1</sup>

This standard is issued under the fixed designation D943; the number immediately following the designation indicates the year of original adoption or, in the case of revision, the year of last revision. A number in parentheses indicates the year of last reapproval. A superscript epsilon ( $\epsilon$ ) indicates an editorial change since the last revision or reapproval.

*This standard has been approved for use by agencies of the U.S. Department of Defense.*

## 1. Scope\*

1.1 This test method covers the evaluation of the oxidation stability of inhibited steam-turbine oils in the presence of oxygen, water, and copper and iron metals at an elevated temperature. This test method is limited to a maximum testing time of 10 000 h. This test method is also used for testing other oils, such as hydraulic oils and circulating oils having a specific gravity less than that of water and containing rust and oxidation inhibitors.

1.2 The values stated in SI units are to be regarded as standard. No other units of measurement are included in this standard.

1.2.1 *Exception*—The values in parentheses in the figures are provided for information for those using old equipment based on non-SI units.

1.3 **WARNING**—Mercury has been designated by many regulatory agencies as a hazardous material that can cause central nervous system, kidney and liver damage. Mercury, or its vapor, may be hazardous to health and corrosive to materials. Caution should be taken when handling mercury and mercury containing products. See the applicable product Material Safety Data Sheet (MSDS) for details and EPA's website—<http://www.epa.gov/mercury/faq.htm>—for additional information. Users should be aware that selling mercury and/or mercury containing products into your state or country may be prohibited by law.

1.4 *This standard does not purport to address all of the safety concerns, if any, associated with its use. It is the responsibility of the user of this standard to establish appropriate safety and health practices and determine the applicability of regulatory limitations prior to use.* For specific warning statements, see Section 6.

1.5 *This international standard was developed in accordance with internationally recognized principles on standard-*

*ization established in the Decision on Principles for the Development of International Standards, Guides and Recommendations issued by the World Trade Organization Technical Barriers to Trade (TBT) Committee.*

## 2. Referenced Documents

### 2.1 ASTM Standards:<sup>2</sup>

A510 Specification for General Requirements for Wire Rods and Coarse Round Wire, Carbon Steel

B1 Specification for Hard-Drawn Copper Wire

D664 Test Method for Acid Number of Petroleum Products by Potentiometric Titration

D1193 Specification for Reagent Water

D3244 Practice for Utilization of Test Data to Determine Conformance with Specifications

D3339 Test Method for Acid Number of Petroleum Products by Semi-Micro Color Indicator Titration

D4057 Practice for Manual Sampling of Petroleum and Petroleum Products

D4310 Test Method for Determination of Sludging and Corrosion Tendencies of Inhibited Mineral Oils

D5770 Test Method for Semiquantitative Micro Determination of Acid Number of Lubricating Oils During Oxidation Testing

E1 Specification for ASTM Liquid-in-Glass Thermometers

E2877 Guide for Digital Contact Thermometers

### 2.2 Energy Institute Standards:<sup>3</sup>

Specifications for IP Standard Thermometers

### 2.3 British Standard:<sup>4</sup>

BS 1829

## 3. Summary of Test Method

3.1 The oil sample is contacted with oxygen in the presence of water and an iron-copper catalyst at 95 °C. The test continues until the measured acid number of the oil is 2.0 mg/g

<sup>1</sup> This test method is under the jurisdiction of ASTM Committee D02 on Petroleum Products, Liquid Fuels, and Lubricants and is the direct responsibility of Subcommittee D02.09.0C on Oxidation of Turbine Oils.

Current edition approved June 15, 2017. Published August 2017. Originally approved in 1947. Last previous edition approved in 2010 as D943 – 04a (2010) <sup>$\epsilon$ 1</sup>. DOI: 10.1520/D0943-17.

In 1976, this test method ceased to be a joint ASTM-IP standard.

<sup>2</sup> For referenced ASTM standards, visit the ASTM website, [www.astm.org](http://www.astm.org), or contact ASTM Customer Service at [service@astm.org](mailto:service@astm.org). For *Annual Book of ASTM Standards* volume information, refer to the standard's Document Summary page on the ASTM website.

<sup>3</sup> Available from Energy Institute, 61 New Cavendish St., London, W1G 7AR, U.K., <http://www.energyinst.org>.

<sup>4</sup> Available from British Standards Institution (BSI), 389 Chiswick High Rd., London W4 4AL, U.K., <http://www.bsigroup.com>.

\*A Summary of Changes section appears at the end of this standard

or above, acid number being the ratio of the mass of KOH in milligrams to the mass of the oil sample in grams. The number of test hours required for the oil to reach the measured acid number of 2.0 mg/g is the “oxidation lifetime.”

#### 4. Significance and Use

4.1 This test method is widely used for specification purposes and is considered of value in estimating the oxidation stability of lubricants, especially those that are prone to water contamination. It should be recognized, however, that correlation between results of this method and the oxidation stability of a lubricant in field service may vary markedly with field service conditions and with various lubricants. The precision statement for this method was determined on steam turbine oils.

NOTE 1—Furthermore, in the course of testing a lubricant by this method, other signs of deterioration, such as sludge formation or catalyst coil corrosion, may appear that are not reflected in the calculated oxidation lifetime. The subcommittee responsible for this method is investigating the application of alternative criteria for evaluation of lubricants using this test apparatus. Test Method D4310 is now available for sludge measurement.

#### 5. Apparatus

5.1 *Oxidation Cell*, of borosilicate glass, as shown in Fig. 1, consisting of a test tube, condenser, and oxygen delivery tube. The test tube has a calibration line at 300 mL (maximum error 1 mL). This calibration applies to the test tube alone at 20 °C.

5.2 *Heating Bath*, thermostatically controlled, capable of maintaining the oil sample in the oxidation cell at a temperature of 95 °C ± 0.2 °C, fitted with a suitable stirring device to provide a uniform temperature throughout the bath, and large enough to hold the desired number of oxidation cells immersed in the heating bath to a depth of 390 mm ± 10 mm and in the heating liquid itself to a depth of 355 mm ± 10 mm.

NOTE 2—Metal block heaters meeting the test method requirements may also be used. It is not known what types of heating baths were used in developing the precision statement.

5.2.1 Studies have suggested that direct sunlight or artificial light may adversely influence the results of this test.<sup>5</sup> To minimize effects of light exposure on the lubricant being tested, light shall be excluded from the lubricant by one or more of the following ways:

5.2.1.1 Use of heated liquid baths that are designed and constructed of metal, or combinations of metals and other suitable opaque materials, that prevent light from entering the test cell from the sides is preferred. If a *viewing window* is included in the design, this *viewing window* shall be fitted with a suitable opaque cover and be kept closed when no observation is being made.

5.2.1.2 If glass heating baths are used, the bath shall be wrapped with aluminum foil or other opaque material.

5.2.1.3 Bright light entering the test cell from directly overhead can be eliminated by use of an opaque shield.

<sup>5</sup> Supporting data (a summary of these results) have been filed at ASTM International Headquarters and may be obtained by requesting Research Report RR:D02-1365.

5.3 *Flowmeter*, with a capacity of at least 3 L/h of oxygen, and an accuracy of ±0.1 L/h.

5.4 *Heating Bath Thermometer*—ASTM Solvents Distillation Thermometer having a range from 72 °C to 126 °C, and conforming to the requirements for Thermometer 40C as prescribed in Specification E1, or for Thermometer 70C as prescribed in Specifications for IP Standard Thermometers. Alternatively, digital contact thermometers such as PRTs (platinum resistance thermometers), thermistors, or thermocouples in accordance with Specification E2877 of equal or better accuracy may be used.

5.5 *Oxidation Cell Thermometer*,<sup>3</sup> having a range from 80 °C to 100 °C, graduated in 0.1 °C, total length—250 mm, stem diameter—6.0 mm to 7.0 mm, calibrated for 76 mm immersion.<sup>6,7</sup> Alternatively, digital contact thermometers such as PRTs, thermistors, or thermocouples in accordance with Specification E2877 of equal or better accuracy may be used.

5.6 *Thermometer Bracket*, for holding the oxidation cell thermometer, of 18-8 stainless steel, having the dimensions shown in Fig. 2. The thermometer is held in the bracket by two fluoroelastomer O-rings of approximately 5 mm inside diameter. Alternatively, thin stainless steel wire may be used.

5.7 *Wire Coiling Mandrel*, as shown in Fig. 3.

5.8 *Abrasive Cloth*, silicon carbide, 100 grit with cloth backing.

5.9 *Syringes*, glass, with Luer-Lok locking connectors, 10 mL and 50 mL capacities for sampling, and water additions, respectively.

5.10 *Syringe Sampling Tube*, Grade 304 stainless steel tubing, 2.11 mm in outside diameter, 1.60 mm in inside diameter, 559 mm ± 2 mm long, with one end finished at 90° and the other end fitted with a Luer-Lok female connector. The Luer-Lok connector is preferably of elastomeric material, such as polyfluorovinylchloride to provide a good seal with the syringe.<sup>8,7</sup>

5.11 *Stopper*, for Luer fitting of syringe sampling tube, made of polytetrafluoroethylene or polyfluorovinylchloride.<sup>9</sup>

5.12 *Sampling Tube Holder*, for supporting the syringe sampling tube, made of methyl methacrylate resin, having the dimensions shown in Fig. 4.

5.13 *Sampling Tube Spacer*, for positioning the end of the sampling tube above the sampling tube holder, made of a length of plastic tubing polyvinyl chloride, polyethylene, polypropylene, or polytetrafluoroethylene having an inside diameter of approximately 3 mm and 51 mm ± 1 mm length.

<sup>6</sup> The sole source of supply of the Brooklyn thermometer No. 21276-RM known to the committee at this time is the Brooklyn Thermometer Co., Farmingdale, NY.

<sup>7</sup> If you are aware of alternative suppliers, please provide this information to ASTM International Headquarters. Your comments will receive careful consideration at a meeting of the responsible technical committee,<sup>1</sup> which you may attend.

<sup>8</sup> The sole source of supply of syringe needles with polychloro-trifluoroethylene hub known to the committee at this time is Hamilton Co., catalog number KF-714.

<sup>9</sup> Suitable stoppers are available from suppliers of infrared spectrometer sample cells.

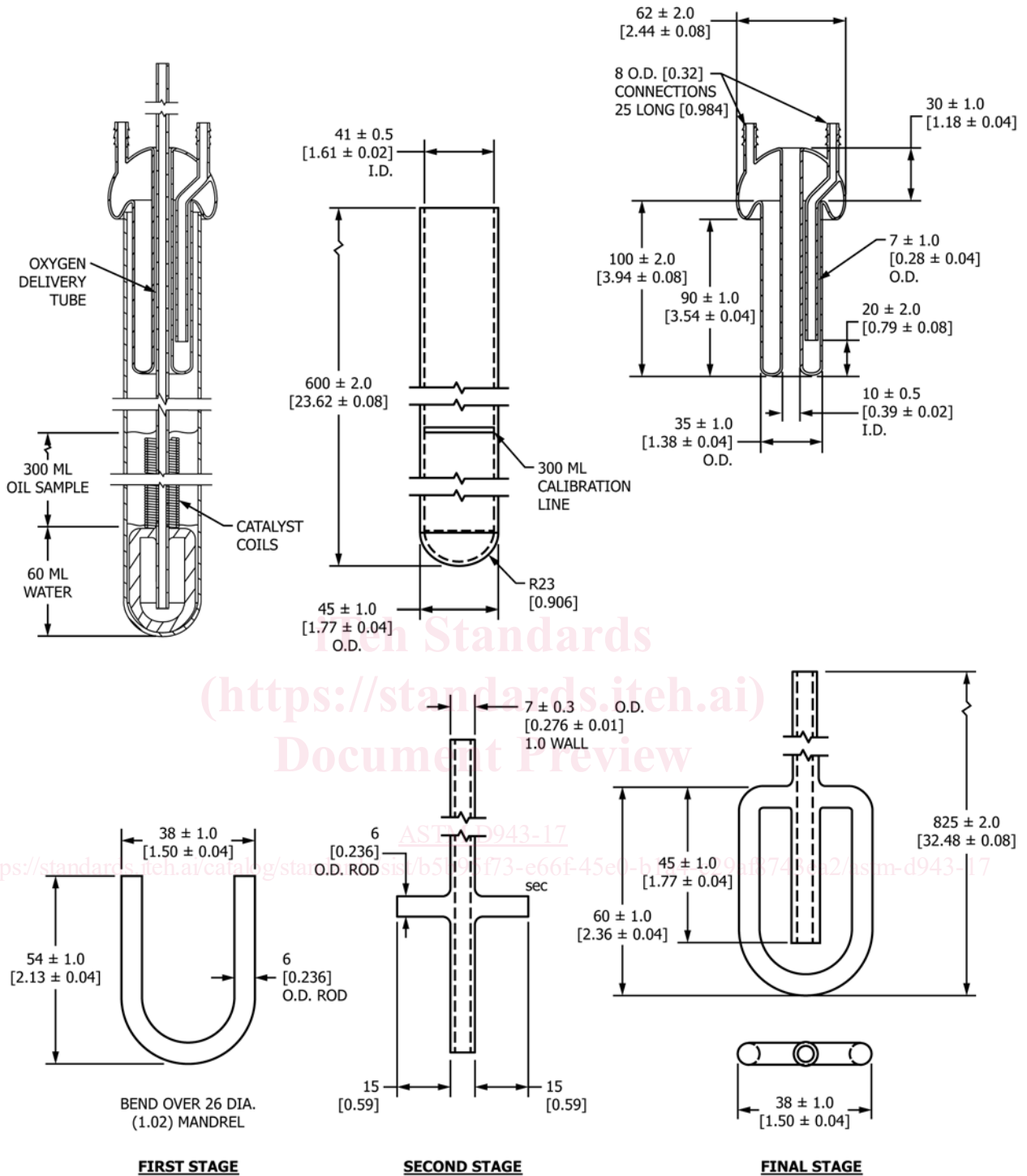

NOTE 1—All dimensions are in millimetres (inches).

NOTE 2—The oxidation test tube has a calibration line at 300 mL. This calibration applies to the test tube alone at 20 °C.

NOTE 3—Open tube ends to be ground and fire-polished.

FIG. 1 Oxidation Cell

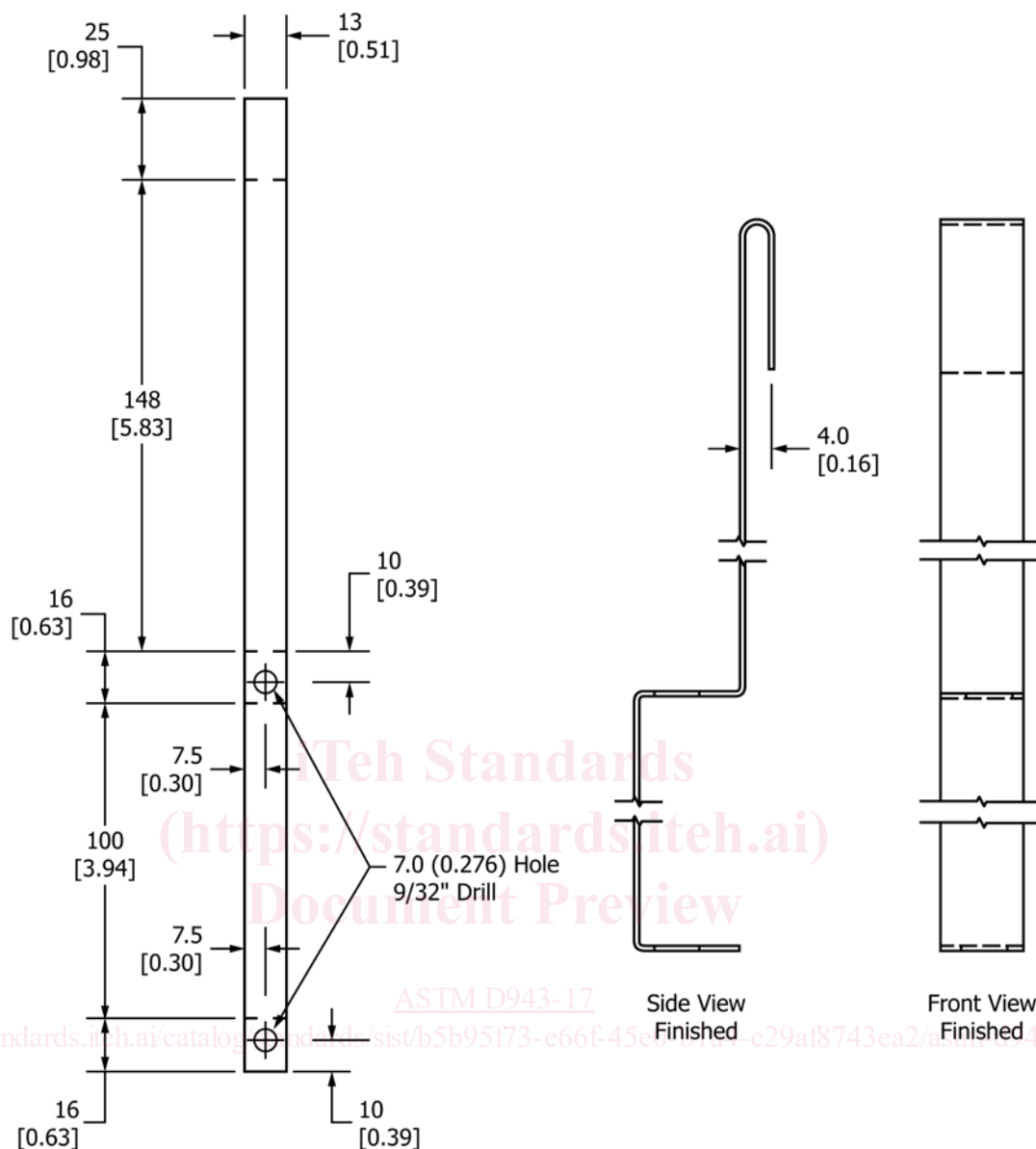

NOTE 1—All dimensions are in millimetres (inches).

NOTE 2—Material: 18-8 Stainless Steel, 22 Gage (0.792 mm).

FIG. 2 Thermometer Bracket

5.14 *Flexible Tubing*, polyvinyl chloride approximately 6.4 mm in inside diameter with a wall for delivery of oxygen to the oxidation cell.

## 6. Reagents and Materials

6.1 *Purity of Water*—Unless otherwise indicated, references to water shall be understood to mean reagent water as defined by Type II of Specification **D1193**.

6.2 *Purity of Reagents*—Reagent grade chemicals shall be used in all tests. Unless otherwise indicated, it is intended that all reagents conform to the specifications of the Committee on Analytical Reagents of the American Chemical Society where

such specifications are available.<sup>10</sup> Other grades may be used, provided it is first ascertained that the reagent is of sufficiently high purity to permit its use without lessening the accuracy of the determination.

6.3 *Acetone*, reagent grade. (**Warning**—Health hazard; flammable.)

<sup>10</sup> *Reagent Chemicals, American Chemical Society Specifications*, American Chemical Society, Washington, DC. For Suggestions on the testing of reagents not listed by the American Chemical Society, see *Annual Standards for Laboratory Chemicals*, BDH Ltd., Poole, Dorset, U.K., and the *United States Pharmacopeia and National Formulary*, U.S. Pharmacopeial Convention, Inc. (USPC), Rockville, MD.

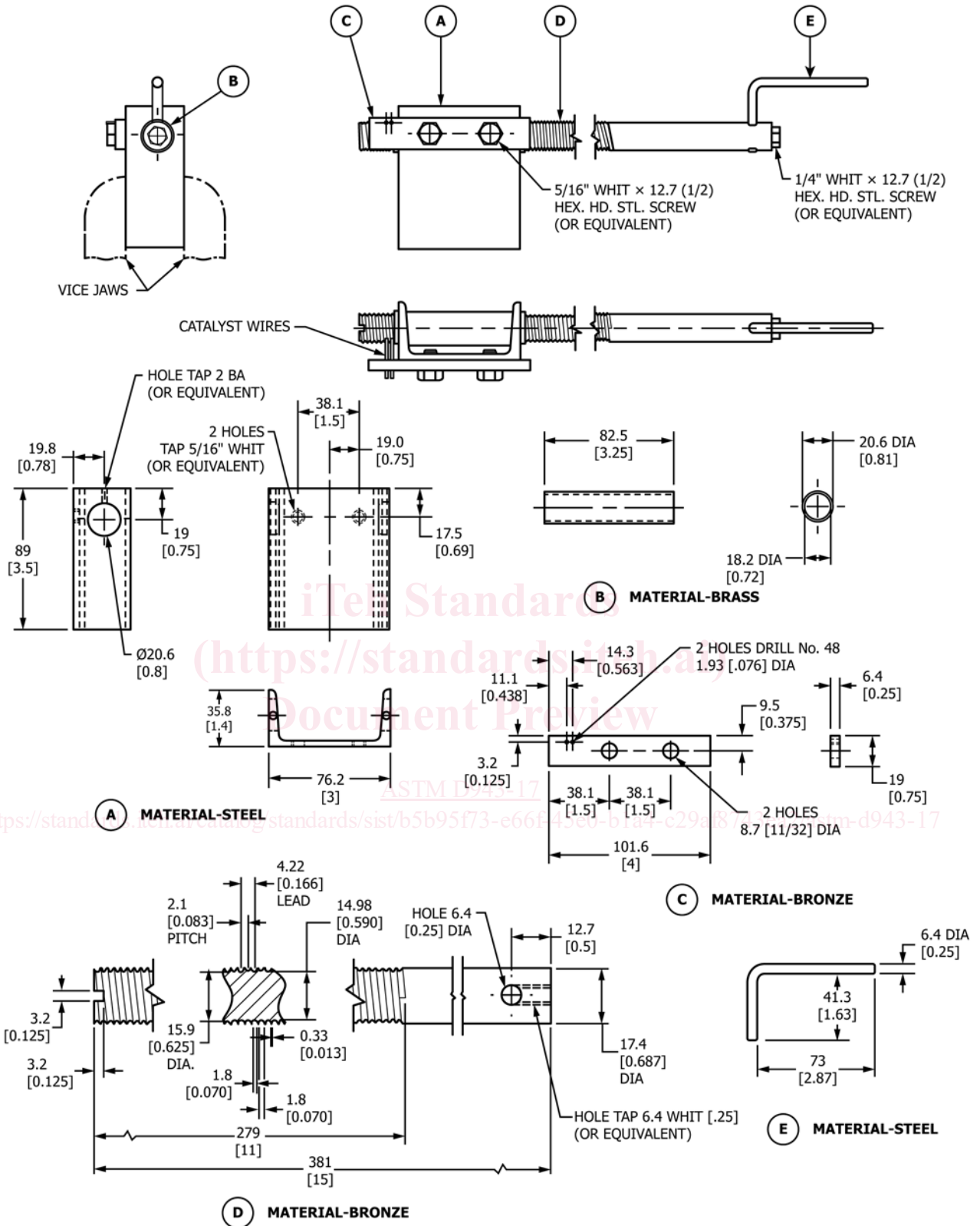

NOTE 1—Dimensions are in millimetres (inches).

FIG. 3 Mandrel for Winding Catalyst Coils

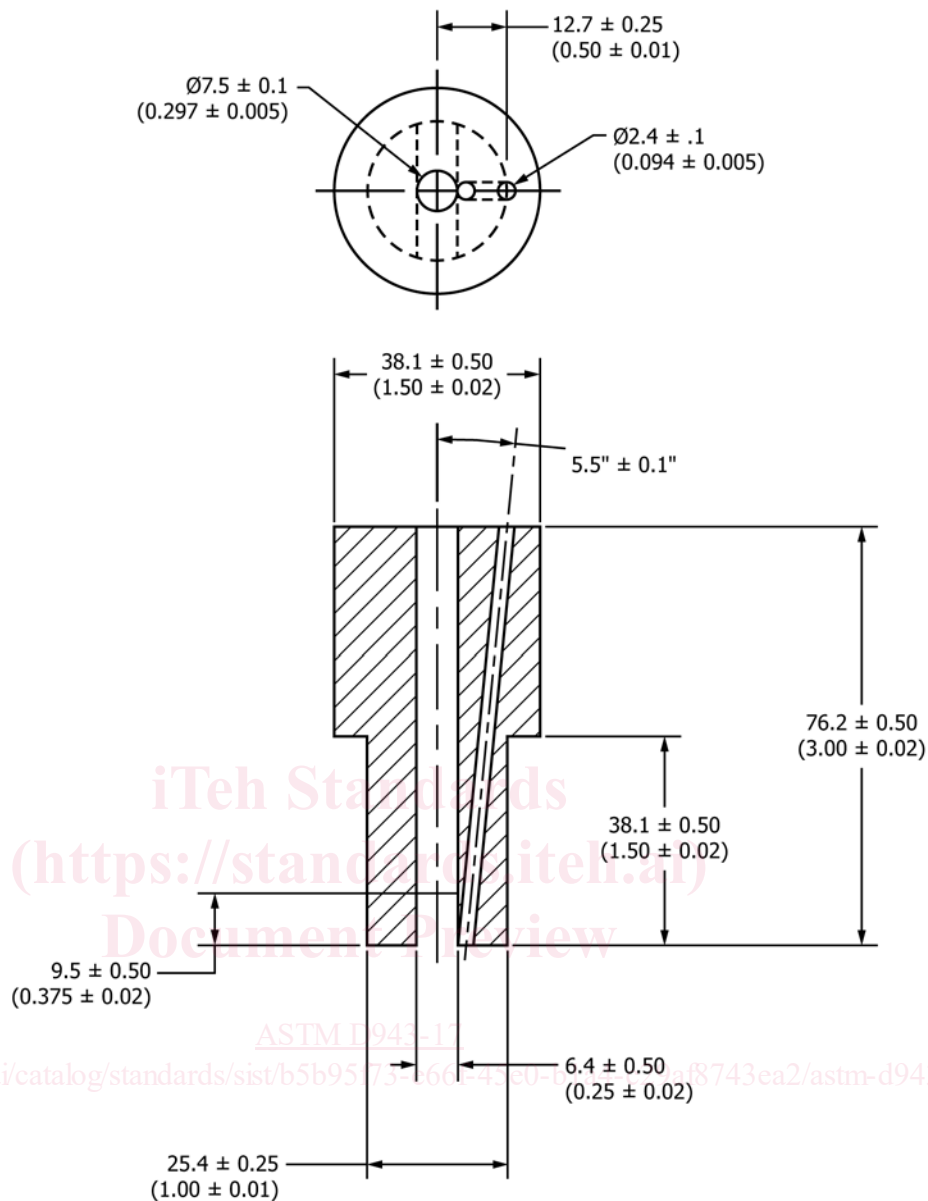

NOTE 1—Dimensions are in millimetres (inches).

FIG. 4 Sampling Tube Holder

6.4 Catalyst Wires:

6.4.1 Low-Metalloid Steel Wire,<sup>11</sup> 1.59 mm in diameter (No. 16 Washburn and Moen Gage).

6.4.2 Electrolytic Copper Wire, 1.63 mm in diameter (No. 16 Imperial Standard Wire Gage or No. 14 American Wire Gage), 99.9 % purity, conforming to Specification B1. Soft copper wire of an equivalent grade may also be used.

<sup>11</sup> Carbon steel wire, soft bright annealed and free from rust, of Grade 1008 as described in Specification A510 is satisfactory. Similar wire conforming to BS 1829 is also satisfactory. If these steels are not available, other equivalent steels may be used, provided they are found to be satisfactory in comparative tests using Test Method D943.

NOTE 3—Alternatively, suitably prepared catalyst coils may be purchased from a supplier.

6.5 Detergent, water-soluble.

6.6 n-Heptane, reagent grade. (**Warning**—Flammable. Harmful if inhaled.)

6.7 Hydrochloric Acid, concentrated [36 mass % (relative density 1.19)]. (**Warning**—Toxic and corrosive.)

6.8 Isopropyl Alcohol, reagent grade. (**Warning**—Flammable.)

6.9 Oxygen, 99.5 % minimum purity, with pressure regulation adequate to maintain a constant flow of gas through the