



Designation: D3123 – 09 (Reapproved 2017)

Standard Test Method for Spiral Flow of Low-Pressure Thermosetting Molding Compounds¹

This standard is issued under the fixed designation D3123; the number immediately following the designation indicates the year of original adoption or, in the case of revision, the year of last revision. A number in parentheses indicates the year of last reapproval. A superscript epsilon (ϵ) indicates an editorial change since the last revision or reapproval.

1. Scope

1.1 This test method covers a procedure for measuring the spiral flow of thermosetting molding compounds (soft or very soft) designed for molding pressures under 6.9 MPa (1000 psi). It is especially suited for those compounds used for encapsulation or other low pressure molding techniques. It involves the use of a standard spiral flow mold in a transfer molding press under specified conditions of applied temperature and pressure with a controlled charge mass.

1.2 The values stated in SI units are to be regarded as standard.

1.3 *This standard does not purport to address all of the safety concerns, if any, associated with its use. It is the responsibility of the user of this standard to establish appropriate safety and health practices and determine the applicability of regulatory limitations prior to use.*

NOTE 1—There is no known ISO equivalent to this test method.

1.4 *This international standard was developed in accordance with internationally recognized principles on standardization established in the Decision on Principles for the Development of International Standards, Guides and Recommendations issued by the World Trade Organization Technical Barriers to Trade (TBT) Committee.*

2. Referenced Documents

2.1 *ASTM Standards:*²

[D883 Terminology Relating to Plastics](#)

[D958 Practice for Determining Temperatures of Standard ASTM Molds for Test Specimens of Plastics](#) (Withdrawn 1995)³

¹ This test method is under the jurisdiction of ASTM Committee D20 on Plastics and is the direct responsibility of Subcommittee D20.30 on Thermal Properties (Section D20.30.08).

Current edition approved Aug. 1, 2017. Published August 2017. Originally approved in 1972. Last previous edition approved in 2009 as D3123 - 09. DOI: 10.1520/D3123-17.

² For referenced ASTM standards, visit the ASTM website, www.astm.org, or contact ASTM Customer Service at service@astm.org. For *Annual Book of ASTM Standards* volume information, refer to the standard's Document Summary page on the ASTM website.

³ The last approved version of this historical standard is referenced on www.astm.org.

[E105 Practice for Probability Sampling of Materials](#)

3. Terminology

3.1 *Definitions*—Definitions in this test method are consistent with Terminology [D883](#).

4. Significance and Use

4.1 The spiral flow of a thermosetting molding compound is a measure of the combined characteristics of fusion under pressure, melt viscosity, and gelation rate under specific conditions.

4.2 This test method is useful as a quality control test and as an acceptance criterion.

4.3 This test method, by itself, is not a valid means for comparing the moldability of similar or different molding compounds because it cannot duplicate actual conditions prevalent in different types of production molds.

4.4 This test method is presently intended for use at a transfer pressure of 6.9 MPa (1000 psi) and a mold temperature of 423 ± 3 K ($150 \pm 3^\circ\text{C}$ ($302 \pm 5^\circ\text{F}$)).

5. Apparatus

5.1 *Transfer Molding Press* with a minimum 150 by 150-mm (6 by 6-in.) platen area, transfer piston pressure potentially greater than 6.9 MPa (1000 psi), sufficient clamp pressure to prevent flashing, and a minimum plunger speed of 25.4 mm (1 in.)/s without load. It is recommended that the plunger be equipped with at least one peripheral sealing groove. It is recommended that a pot diameter between 31.75 and 44.45 mm (1.25 and 1.75 in.) be used whenever a choice is possible.

NOTE 2—Preliminary evidence indicates that, in many cases, reasonable correlations may be achieved between laboratories using presses with different pot diameters. Typical examples are presses with pot diameters of 31.750, 38.100, and 44.450 mm (1.250, 1.500, and 1.750 in.). However, a few well-documented cases are recorded where differences in pot diameters, even within this listed range, have caused large differences in flow-length readings. Therefore, for best interlaboratory correlation it is recommended that identical pot diameters be used.

5.2 *Standard Spiral-Flow Mold* shown in [Fig. 1](#) shall be utilized.

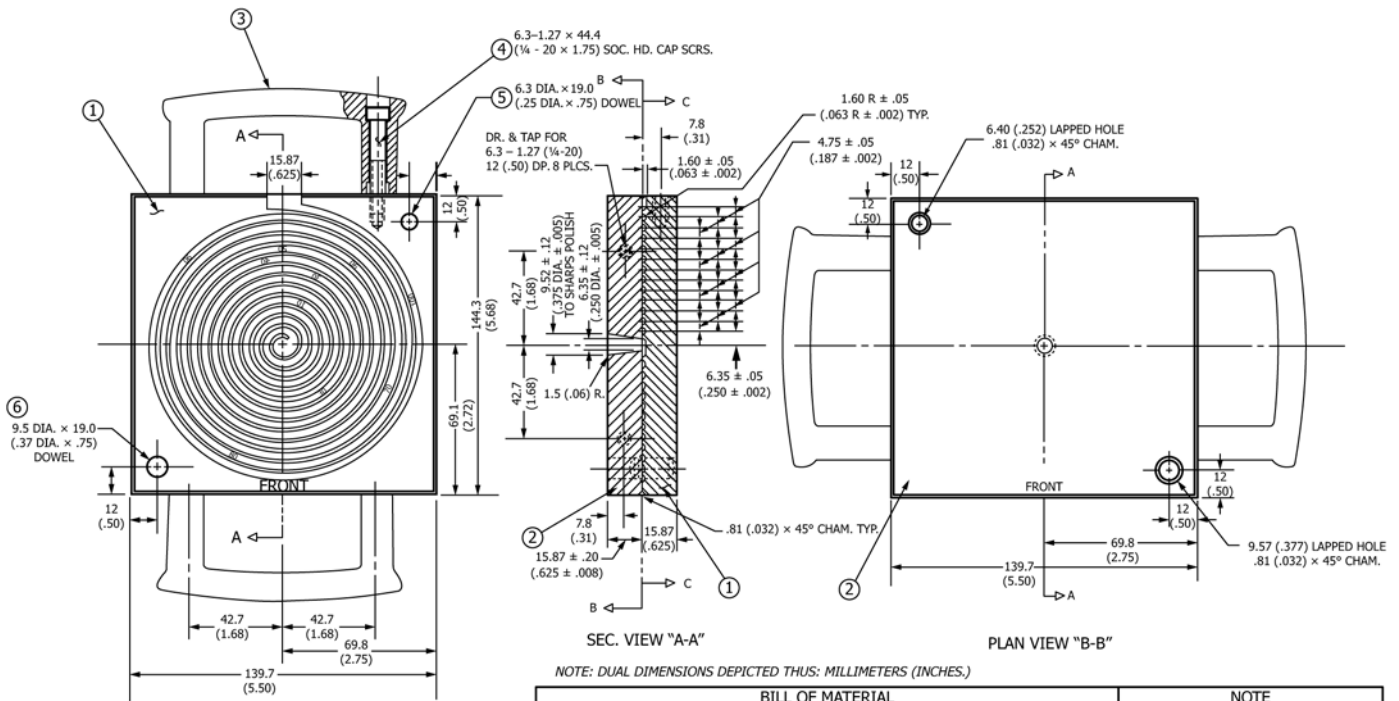

NOTE: DUAL DIMENSIONS DEPICTED THUS: MILLIMETERS (INCHES.)

BILL OF MATERIAL					NOTE
ITEM NO.	NO. REQ.	DESCRIPTION	SIZE	MATERIAL	
1	1	SPRAL MOLD PLATE	16 (5/8) × 138 (5 7/16) × 140 (5 1/2)	A.H.T.S.	1. SPIRAL IS A GENERATED SPIRAL. NO OFFSET.
2	1	SPRUE PLATE	16 (5/8) × 138 (5 7/16) × 140 (5 1/2)	"	2. MOLD SURFACES ARE HIGH POLISH & FLASH CHROME PLATE.
3	4	HULL STD. HANDLES		PLASTIC	3. INDENTATION AT SPIRAL ENTRY IS ZERO MM (INCHES). INDENTATIONS EVERY 25.4 (1.00) ALONG C OF SPIRAL ARE NUMBERED AT LEAST EVERY 254 MM (10 IN.)
4	8	SOC. HD. CAP. SCREWS	6.3-1.27 (1/4-20) × 44.4 (1 3/4)	STEEL	
5	1	DOWEL PIN	6.3 (1/4) DIA. × 19 (3/4)	"	
6	1	DOWEL PIN	9.5 (3/8) DIA. × 19 (3/4)	"	

FIG. 1 Standard Spiral-Flow Mold

6. Materials

6.1 Molding Compound:

6.1.1 Any thermosetting molding compound with a spiral flow between 762 and 1270 mm (30 and 50 in.) as determined at the standard temperature and pressure of this test can be evaluated.

NOTE 3—Since the only commercially available molds are calibrated in inches, spiral-flow length will be reported in these units. Conversion to SI units can readily be made by multiplying the flow length, in inches, by the appropriate conversion factor, 25.4 mm/in.

NOTE 4—There is considerable evidence that the test is usable over a wider range of flow lengths, but this has not yet been confirmed by interlaboratory testing.

6.1.2 Form—The form of the molding compound shall be loose powder or granules at 296 ± 2 K (23 ± 2°C (73.4 ± 3.6°F)).

NOTE 5—Preforms or pellets may be used if found necessary; however, flow length may be affected by their use.

7. Sampling

7.1 Unless otherwise agreed upon between the seller and purchaser, sampling shall be in accordance with Practice E105. Sampling, based on engineering principles, prior to packaging shall be considered an acceptable alternative.

8. Conditioning

8.1 Conditioning—All molding compounds shall be tested in “as-received” condition. For referee testing, all material shall be shipped and stored in moisture-barrier containers. They shall be stored for a minimum of 24 h at the standard laboratory temperature, before breaking the seal on the container. Take care to preserve the “as-received” moisture content and tests shall be made as soon as possible once the container has been opened. Alternative methods of conditioning samples shall be mutually agreed upon between manufacturer and purchaser.

9. Test Conditions

9.1 Spiral-Flow Mold—The mold shall be clean and free from any mold-release agents or lubricants. Several preliminary moldings shall be made with the material to be tested to purge the helical runner before beginning the test. This procedure is essential when changing from one compound to another and is recommended as a routine practice.

9.2 Molding Conditions:

9.2.1 Temperature—A temperature of 423 ± 3 K (150 ± 3°C (302 ± 5°F)) shall be maintained on the mold and transfer plunger. Measure the temperature in accordance with the procedures described in Practice D958 or by thermocouples