



Designation: D7140/D7140M – 13 (Reapproved 2017)

Standard Test Method to Measure Heat Transfer Through Textile Thermal Barrier Materials¹

This standard is issued under the fixed designation D7140/D7140M; the number immediately following the designation indicates the year of original adoption or, in the case of revision, the year of last revision. A number in parentheses indicates the year of last reapproval. A superscript epsilon (ϵ) indicates an editorial change since the last revision or reapproval.

1. Scope

1.1 This test method covers the evaluation of heat transfer of textile materials which are used as thermal barriers when exposed to a calibrated convective and radiant energy heat source for 60 s.

1.1.1 This standard is used to determine if the heat transfer is sufficient to ignite flammable materials which are contiguous to the textile thermal barriers.

1.2 This standard is used as a means to differentiate textile materials.

1.3 This test method is not intended to measure the insulation properties of materials used in protective clothing.

1.4 The values stated in either SI units or inch-pound units are to be regarded separately as standard. The values stated in each system may not be exact equivalents; therefore, each system shall be used independently of the other. Combining values from the two systems may result in non-conformance with the standard.

1.5 This standard is used to measure and describe the response of materials, products, or assemblies to heat and flame under controlled conditions, but does not by itself incorporate all factors required for fire hazard or fire risk assessment of the materials, products or assemblies under actual fire conditions.

1.6 *This standard does not purport to address all of the safety concerns, if any, associated with its use. It is the responsibility of the user of this standard to establish appropriate safety, health and environmental practices and determine the applicability of regulatory limitations prior to use.*

1.7 *This international standard was developed in accordance with internationally recognized principles on standardization established in the Decision on Principles for the Development of International Standards, Guides and Recommendations issued by the World Trade Organization Technical Barriers to Trade (TBT) Committee.*

¹ This standard is under the jurisdiction of ASTM Committee D13 on Textiles and is the direct responsibility of Subcommittee D13.52 on Flammability.

Current edition approved July 15, 2017. Published August 2017. Originally approved in 2005. Last previous edition approved in 2013 as D7140 – 13. DOI: 10.1520/D7140_D7140M-13R17.

2. Referenced Documents

2.1 *ASTM Standards:*²

D123 Terminology Relating to Textiles

D4391 Terminology Relating to The Burning Behavior of Textiles

2.2 *Other Standards:*

State of California, Technical Bulletin 603 Requirements and Test Procedures for Resistance of a Mattress/Boxspring Set to a Large Open Flame, January, 2004³

Code of Federal Regulations – Title 16 – Consumer Product Safety Commission Part 1633, Standard for the Flammability of Mattress Sets⁴

3. Terminology

3.1 The following terms are relevant to this standard: break open, charring, dripping, embrittlement, exposure energy to thermal end point, heat flux, ignition, melting, shrinkage.

3.1.1 For all terminology relating to D13.52, Flammability, refer to Terminology D4391.

3.2 For all terminology related to Textiles see Terminology D123.

4. Summary of Test Method

4.1 A textile thermal barrier that is used to prevent transfer of heat to flammable materials which are contiguous to this barrier are exposed to a controlled radiant and convective heat source for 60 s.

4.2 The heat transfer is measured using a data collection system.

4.3 Performance of thermal barrier textile material is determined by the amount of heat transferred through the specimen.

² For referenced ASTM standards, visit the ASTM website, www.astm.org, or contact ASTM Customer Service at service@astm.org. For *Annual Book of ASTM Standards* volume information, refer to the standard's Document Summary page on the ASTM website.

³ Available from the State of California.

⁴ Available from U.S. Consumer Product Safety Commission (CPSC), 4330 East West Hwy., Bethesda, MD 20814, <http://www.cpsc.gov>.

5. Significance and Use

5.1 This test method measures the level of heat transfer through the thermal barrier textile material within a specific period of time.

5.2 This test method is used to evaluate thermal barriers and determine if they are able to withstand impingement by an open flame.

5.2.1 This test method is used to evaluate heat transfer when thermal barrier textile materials are used in conjunction with materials that demonstrate any of the following behaviors when exposed to high heat:

- break open
- charring
- dripping
- embrittlement
- ignition
- melting
- shrinkage

5.3 This test method cannot be used in place of the full scale test method TB603 or 16 CFR 1633.

NOTE 1—This test method is intended to be used to evaluate thermal barrier textile material, used as the thermal barrier component for mattresses that are tested to comply with California Technical Bulletin 603 (TB603) or with 16 CFR 1633, two standards which are technically identical. Data obtained by using this method is intended to provide information as to whether it would be helpful to proceed with the full scale testing.

5.3.1 This test method can be used as part of a supplier quality assurance program.

5.4 This test method is not intended to be used in evaluating heat transfer of thermal barrier textile materials used in protective clothing.

5.5 This test method is not recommended for acceptance testing of commercial shipments, since information on inter-laboratory precision is incomplete. In some cases the purchaser and the supplier shall agree to test a commercial shipment of one or more specific materials and establish their own inter-laboratory precision and bias, and also agree on acceptability limits.

6. Apparatus

6.1 Arrange components as shown in Fig. 1.

6.1.1 Details of the calorimeter construction are shown in Fig. 2.

6.2 Liquid propane or natural gas with appropriate reducer and valving arrangement.

6.3 A gas rotometer with range to give flow equivalent to 2 L [0.007 ft³]/min. air at standard conditions.

6.4 Meeker or Fisher burner with 38 mm [1.5 in.] diameter top and with orifice size of 1.2 mm [3/64 in.] for natural gas. Propane requires a special orifice.

6.5 Copper calorimeter mounted in an insulating block and constructed as shown in Fig. 2.

6.5.1 Calorimeter is painted black using a high temperature flat black stove pipe primer.

6.6 Dimensions for two (2) mounting plates are Length 152 mm [6 in.], Width 152 mm [6 in.], each with a 76 mm [3 in.] by 76 mm [3 in.] hole in center. Each plate thickness is 3 mm [1/8 in.]. See Fig. 3. The bottom plate which faces the flame must be made of steel. The top plate must also be made of steel.

6.7 Any strip chart recorder with full scale deflection of at least 150° C [300°F] or 10 mV and sufficient sensitivity and scale divisions to read sensor response to 1°C [2° F] or ±0.05 mv. A chart speed to read exposure time to ±0.01 s is required.

6.8 Specimen Holder, see Fig. 3 Three complete assemblies are desirable.

6.9 Laboratory standard ring support and clamp are used to hold specimen holder assembly and position the burner.

7. Hazards

7.1 Perform the test in a hood or ventilated area to carry combustion products away. If air currents disturb the flame, shield the apparatus or turn off the hood while running the test, then turn the hood on after the test to clear fumes. Exercise care in handling the burner with the open flame. Maintain adequate separation between flame and combustible materials.

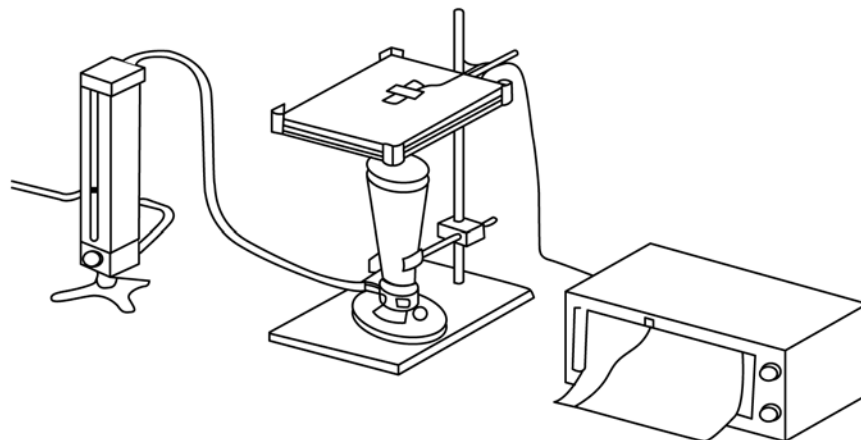

FIG. 1 Test Apparatus

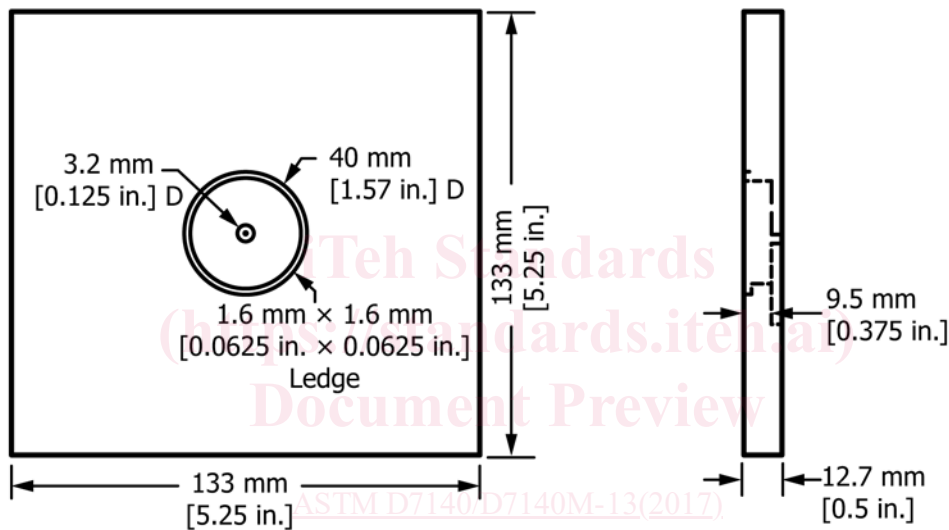
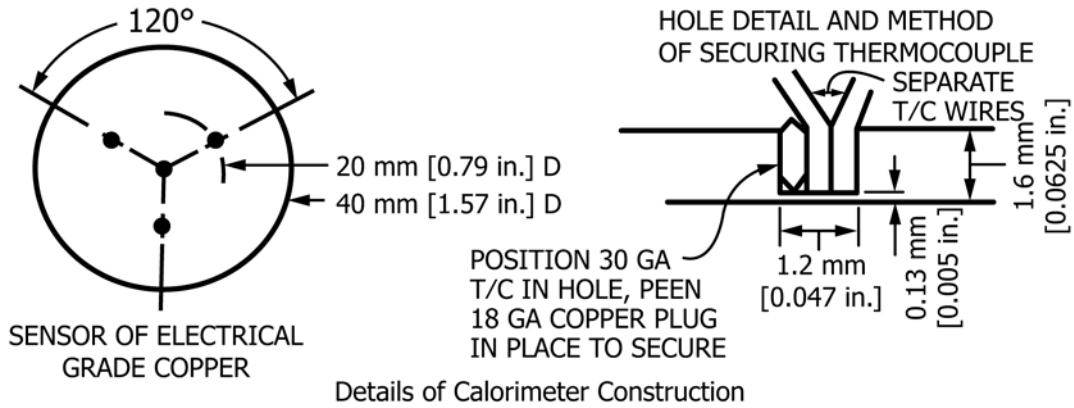

FIG. 2 Calorimeter Placement

7.2 The specimen holder and calorimeter assembly can become heated during prolonged testing. Use protective gloves when handling these hot objects.

NOTE 2—Some test specimens are hazardous when exposed to direct flames. Use care when the ignited specimen releases combustible gases. Remove the burner using gloves and allow the sample to burn out, or smother it with a plate.

7.3 Shut off the gas supply at the cylinder and allow flame to burn the gas from the lines when testing is completed.

8. Sampling and Test Specimen Preparation

8.1 *Lot Sample*—Randomly select the number of rolls or pieces of fabric directed in an applicable material specification or other agreement between the purchaser and the supplier. Consider the rolls or pieces of fabric to be the primary sampling units. In the absence of such an agreement, take the number of fabric rolls specified in Table 1. Consider a single

shipment of one style of fabric as the lot. A lot may constitute part of a single customer order.

NOTE 3—An adequate specification or other agreement between the purchaser and supplier requires taking into account the variability between rolls or pieces of fabric and between specimens from a swatch from a roll or piece of fabric to provide a sampling plan with a meaningful producer's risk, consumer's risk, acceptable quality level, and limiting quality level.

8.2 *Laboratory Sample*—Take a swatch extending the width of the fabric and approximately 1 m [1 yd] along the machine direction from each roll or piece in the lot sample. For rolls of fabric, take a sample that will exclude fabric from the outer wrap of the roll or the inner wrap around the core of the roll of fabric.

8.3 *Test Specimens*—Cut and identify five test specimens from each swatch in the laboratory sample. Make each test specimen 133 by 133 ± 2 mm [5.25 by 5.25 ± 1/16 in.] with two sides of the specimen parallel with either the machine