



Designation: D8127 – 17

# Standard Test Method for Coupled Particulate and Elemental Analysis using X-ray Fluorescence (XRF) for In-Service Lubricants<sup>1</sup>

This standard is issued under the fixed designation D8127; the number immediately following the designation indicates the year of original adoption or, in the case of revision, the year of last revision. A number in parentheses indicates the year of last reapproval. A superscript epsilon ( $\epsilon$ ) indicates an editorial change since the last revision or reapproval.

## 1. Scope

1.1 This automatic wear particle analysis<sup>2</sup> test method for in-service lubricants describes using a combination of pore blockage particle counting and energy dispersive X-ray fluorescence (EDXRF) spectrometry for the quantitative determination of solid particle counts larger than four (4) micrometres, and elemental content of suspended particulate of iron (Fe) and copper (Cu) in such lubricants.

1.2 This test method provides for the determination of the elemental content of suspended particulate of Fe greater than 4  $\mu\text{m}$  in the range of 6 mg/kg to 223 mg/kg. Suspended particulate of copper greater than 4  $\mu\text{m}$  is determined in the range of 3.5 mg/kg to 92.4 mg/kg in the lubricant. Total particle count greater than 4  $\mu\text{m}$  is determined in the range of 11 495 particles/mL greater than 4  $\mu\text{m}$  to 2 169 500 particles/mL greater than 4  $\mu\text{m}$  in the lubricant.

1.3 This test method is applicable to all known in-service lubricants (API Groups I-V) at any stage of degradation.

1.4 This test method uses an empirical inter-element correction methodology.

1.5 The values stated in SI units are to be regarded as standard. No other units of measurement are included in this standard.

1.6 *This standard does not purport to address all of the safety concerns, if any, associated with its use. It is the responsibility of the user of this standard to establish appropriate safety and health practices and determine the applicability of regulatory limitations prior to use.*

1.7 *This international standard was developed in accordance with internationally recognized principles on standard-*

<sup>1</sup> This test method is under the jurisdiction of ASTM Committee D02 on Petroleum Products, Liquid Fuels, and Lubricants and is the direct responsibility of Subcommittee D02.03 on Elemental Analysis.

Current edition approved July 1, 2017. Published August 2017. DOI: 10.1520/D8127-17.

<sup>2</sup> Iron (Fe) and copper (Cu) alloy metals are common elements for machine load bearing surfaces including bearings, gears, pistons, rings, valves, pins, couplings, and cylinders. This in-service lubricant analysis method addresses common challenges associated with extracting, counting, sizing, and elementally analyzing telltale wear debris so that appropriate observations and actions may be recommended.

*ization established in the Decision on Principles for the Development of International Standards, Guides and Recommendations issued by the World Trade Organization Technical Barriers to Trade (TBT) Committee.*

## 2. Referenced Documents

### 2.1 ASTM Standards:

D4057 Practice for Manual Sampling of Petroleum and Petroleum Products

D5854 Practice for Mixing and Handling of Liquid Samples of Petroleum and Petroleum Products

D4177 Practice for Automatic Sampling of Petroleum and Petroleum Products

D7669 Guide for Practical Lubricant Condition Data Trend Analysis

D7720 Guide for Statistically Evaluating Measurand Alarm Limits when Using Oil Analysis to Monitor Equipment and Oil for Fitness and Contamination

D7751 Test Method for Determination of Additive Elements in Lubricating Oils by EDXRF Analysis

D7874 Guide for Applying Failure Mode and Effect Analysis (FMEA) to In-Service Lubricant Testing

E1621 Guide for Elemental Analysis by Wavelength Dispersive X-Ray Fluorescence Spectrometry

### 2.2 ISO Standards:<sup>3</sup>

ISO 21018:3 Hydraulic fluid power—Monitoring the level of particulate contamination of the fluid—Part 3: Use of the filter blockage technique

## 3. Terminology

### 3.1 Definitions of Terms Specific to This Standard:

3.1.1 *contaminant particles, n*—particles introduced from an extraneous source into the lubricant of a machine or engine.

3.1.2 *empirical inter-element correction, n*—linear inter-element correction that is constructed from a matrix of calibration samples prepared with varying levels and amounts of known interferences. By diagonalizing the matrix of elements and interferences, an equation for the inter-element corrections for each element of interest is obtained.

<sup>3</sup> Available from American National Standards Institute (ANSI), 25 W. 43rd St., 4th Floor, New York, NY 10036, <http://www.ansi.org>.

3.1.3 *filter active area, n*—area of the filter membrane through which liquid is flowing.

3.1.3.1 *Discussion*—An example filter active area is 0.32 square centimetre (cm<sup>2</sup>).

3.1.4 *filter cartridge, n*—disposable assembly consisting of a plastic filter holder, and the filter membrane itself mounted over a sealing plastic feedthrough.

3.1.4.1 *Discussion*— On the back side of the plastic feedthrough, against which the filter membrane is mounted, a piece of felt is mounted, through which the liquid exits the filter cartridge. The felt is used to wick any remaining liquid off the filter membrane once the syringing process is completed.

3.1.5 *filter membrane, n*—a thin, flat, and smooth disposable membrane with circular pores of approximately 4 µm in capture diameter.

3.1.5.1 *Discussion*—An example would be a polycarbonate track-etched membrane. There are approximately 32 000 of such pores in the filter active area. Note that the nominal pore size is 5 µm in diameter but the membrane manufacturing process yields an effective pore capture diameter of approximately 4 µm due to observed edge material on the pores.

3.1.6 *interrogated material, n*—solid material present on the filter membrane that is analyzed by the EDXRF spectrometer.

3.1.7 *layering effect, n*—complex interferences of the EDXRF spectrometry due to the formation of multiple layers of particulate on sample that is being analyzed.

3.1.7.1 *Discussion*—When multiple layers are present, incident X-rays are attenuated as they travel through multiple layers of the sample, and interferences between X-rays emerging from various layers of the sample may affect the analysis.

3.1.8 *neat sample, n*—a sample of in-service lubricant drawn directly from the machinery without further processing.

3.1.9 *suspended particulate, n*—particles, including contaminant, wear, and soft particles, which can be trapped by a membrane filtration process.

3.1.10 *syringing, v*—process by which a syringe is emptied through a filter by way of applied force using a linear actuator on its plunger.

3.1.10.1 *Discussion*—The filter is sealed to the syringe to ensure that fluid passes from the syringe and through the filter only.

3.1.11 *wear, n*—damage to a solid surface, usually involving progressive loss or displacement of material, due to relative motion between that surface and a contacting substance or substances.

3.1.12 *wear particles, n*—particles generated from wearing surfaces of a machine or engine.

3.1.13 *X-ray calibration standard, n*—a paraffin wax puck in which is embedded various known amounts of metal powders.

3.1.13.1 *Discussion*—This check standard is placed in the EDXRF in order to provide a simple re-calibration of the device by the operator.

## 4. Summary of Test Method

4.1 This test method describes means by which particulate can be trapped from neat in-service lubricants, probed for particulate characteristics, and subsequently analyzed for elemental content. This test method describes, from this process, means by which a total particle count in particles per millilitre of lubricant (particles/mL) may be obtained in accordance with ISO 21018:3 for particles greater than 4 µm.

4.2 The EDXRF spectrometer provides the fluorescence spectrum, from which the elemental concentrations of iron and copper are calculated using their respective fundamental  $K\alpha$  lines by way of the established calibration that includes inter-element corrections. Compton backscattering corrections may also be applied.

## 5. Significance and Use

5.1 It has been shown in many industries that separating information regarding small or dissolved elemental materials in the lubricant from suspended particulate is crucial. In many cases only an overall elemental analysis is provided, which may not capture significant wear or even machinery failure events. Such events are often accompanied by a sudden increase in the production of large particulate, which is suspended in and can be detected in the machinery's lubricant. This test method specifically targets such particulate, which has historically been difficult to quantify. Users of the technique include numerous military organizations, and maintainers of wind turbines, nuclear power facilities, and offshore rigs.

## 6. Interferences

6.1 The filter presented for EDXRF analysis will have a small amount of residual in-service lubricant. If any of the elements being monitored is present in significant amounts (>500 mg/kg) in dissolved form in the lubricant, the EDXRF will see additional signal due to that dissolved elemental material and report a positively biased signal for that element.

6.2 Self-absorption, matrix, and inter-element effects (beyond the empirical correction factors), which are discussed in, for example, Test Method **D7751**, are well-known and can interfere with the reported quantities of each element. Further, no inter-element correction procedures have been developed for interfering elements which are outside the scope of this test method, but may nonetheless be present in the in-service lubricant. Since the interrogated material thickness is significantly smaller than the X-ray beam penetration and layering effects are small, these interfering effects are minimized, but will still occur when any element is present in quantities greater than the range of calibration (500 mg/kg).

6.3 Peculiar particle size distribution will affect the accuracy of the particle count. Common particle size distributions demonstrate power law decay, where counts increasingly decline as size increases. A high bias in particle count has been observed when more small particles (4 µm to 6 µm in diameter) than the expected power law distribution are present by a factor of more than two. Similarly, when there are fewer small particles than expected by less than half, a low bias is expected. No bias has been observed when there is an abnormal large

particle distribution. For example, the method has been tested to stay within specified calibration up to a mass distribution of suspended particulate as a function of particle size which is approximately flat from 4  $\mu\text{m}$  to 35  $\mu\text{m}$ . Such a distribution would indicate an abnormally high presence of large particles (greater than 6  $\mu\text{m}$  in diameter) up to a factor of 6 relative to the expected power law distribution.

## 7. Apparatus

7.1 A sample processing system consisting of the following:

7.1.1 A disposable filter cartridge functionally similar the one shown in Fig. 1, which serves the purpose of holding the filter membrane in place during the syringing process, as well as ensuring that fluid flows through the active area of the filter membrane, out the back of the filter cartridge and a drain to waste.

7.1.2 A syringing apparatus, into which the syringe and filter cartridge are mounted and in-service lubricant syringed through the filter. A typical setup shown in Fig. 2 contains associated pressure monitoring sensors, linear actuator to perform the syringing, limit switches for the actuator, and drain to waste.

NOTE 1—The syringing apparatus is mounted perpendicular to the ground, and the filter cartridge is mounted into the syringing apparatus parallel to the ground, again to prevent any captured particulate from being urged off or displaced from the filter active area. Fig. 3 provides a figurative example of a syringe dispensing profile characterizing pore blockage in the active area of the filter membrane. As lubricant is syringed through the filter membrane active area (x-axis of Fig. 3), suspended particulate will register as an increase in differential pressure (y-axis of

Fig. 3) across the membrane, as the pores in the active area become filled with this particulate. The pressure increase based on the amount of lubricant syringed can be directly related to the overall particle count in the lubricant.

7.1.2.1 A predefined particle concentration limit is selected and corresponds to a point on the dispensing profile at which a predefined percentage of pores in the active area of the filter membrane have been blocked. Particle concentration limits are validated using appropriate concentrations of standardized test dust in liquid medium such as the NIST (SRM 2806b) test dust standard or another well classified standard dust in liquid medium.

7.1.3 An energy-dispersive X-ray fluorescence spectrometer (EDXRF), as described in Test Method D7751, with a programmable voltage tube, with a maximum tube voltage rating sufficient to fluoresce the  $K\alpha$  lines of copper and iron.

NOTE 2—The EDXRF is preferably mounted with its sample interface area facing towards the ground. This prevents any liquid from dripping into the window of the EDXRF, or any particulate captured on the filter membrane from moving off the filter active area. A typical arrangement is shown in Fig. 4.

## 8. Reagents and Materials

8.1 NIST (SRM 2806b) test dust standard or another appropriate and well classified standard dust in liquid medium should be obtained to provide calibration checks for the particle count.

8.2 Wax EDXRF calibration standard is provided by the manufacturer. These are fabricated using consumer grade

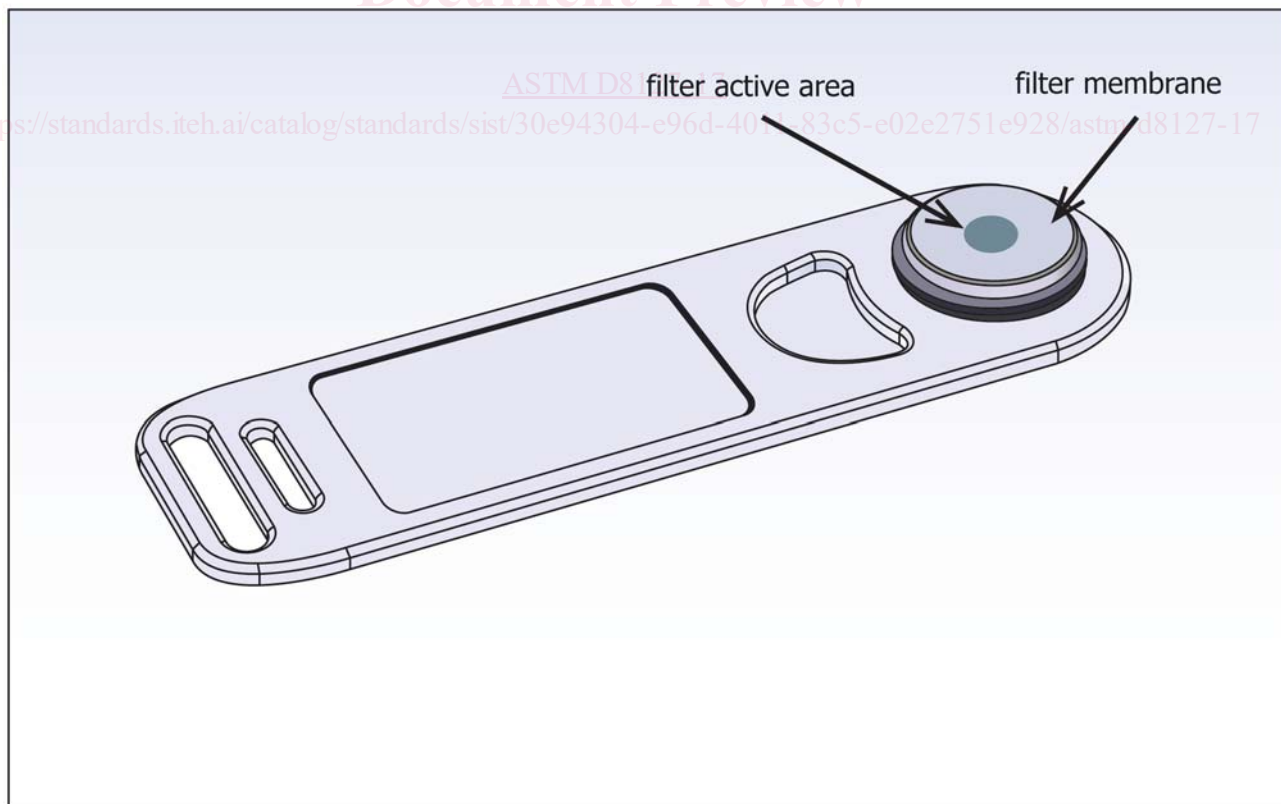

FIG. 1 Disposable Filter Cartridge

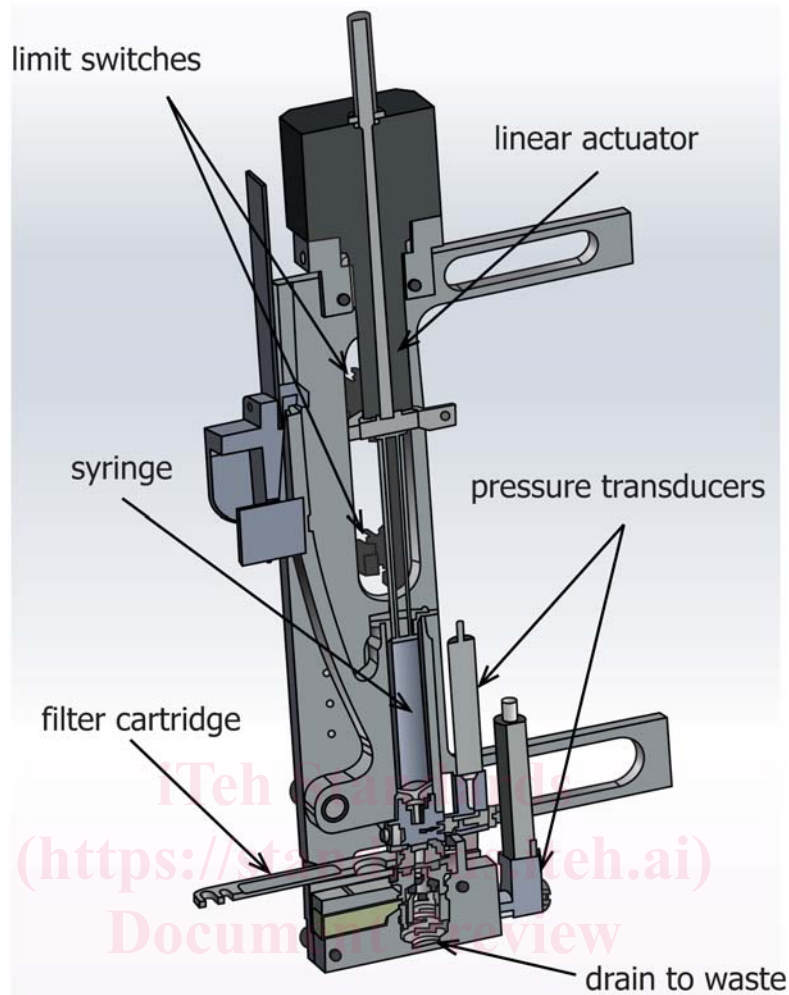

FIG. 2 Example Syringing Apparatus Cross-section

<https://standards.iteh.ai/catalog/standards/sist/30e94304-e96d-4011-83c5-e02e2751e928/astm-d8127-17>

paraffin canning wax as the base support material in the following fashion: Warm 10 g to 20 g of the wax to near melting (50 °C to 55 °C), then add a small amount (~0.5 mg) of each powdered metal (average particle size  $\leq 10 \mu\text{m}$ , minimum 99 % purity) of interest (examples are FE-M-02M-P 10 UM for iron and CU-M-02M-P 10 UM for copper from American Elements, Los Angeles, CA). Knead the wax/metal mixture by hand (using plastic gloves) until the metal powder is evenly dispersed throughout the wax. This usually requires several cycles of re-warming the wax to soften it enough for effective kneading. The original wax mixture is usually too concentrated in the metal powder, so must be diluted with up to tenfold clean paraffin wax. After the metal powders are evenly dispersed throughout the wax, a modified disposable filter cartridge is used to hold the final standard. A 6 cm hole is put in place of the filter membrane. This hole is filled with the warm wax standard, pressing the wax in by hand. The excess wax may be sliced off the top and bottom of the disposable filter cartridge using a razor blade.

8.3 Plastic, disposable syringe which can hold between 3 mL and 30 mL of liquid. Consult the manufacturer's instructions for syringe style needed for the apparatus.

8.4 Polypropylene industrial wipes or a clean cotton shop towel to clean the apparatus.

8.5 Disposable plastic waste bag or equivalent to capture the effluent liquid from the syringing process.

## 9. Hazards

9.1 Potential hazards arising from the presence of X-rays arising from a high-voltage tube source should be noted and proper health and safety precautions should be followed. Please see Guide E1621 for more considerations.

9.2 All precautions in the sampling and handling of in-service lubricant samples should be followed as appropriate. See Practices D4057 or D4177 for guidance.

## 10. Sampling, Test Specimens, and Test Units

10.1 A sample of the liquid should be obtained following the guidelines described in Practices D4057 or D4177. A representative portion of the lubricant and of sufficient volume to fill the syringe should be collected in a clean, dry container. Care should be taken to ensure that the portion collected is as representative of the fluid as possible. Avoid sampling from the