

INTERNATIONAL STANDARD

ISO 4074-6

Third edition
1996-08-15

Rubber condoms —

Part 6:

Determination of bursting volume
and pressure

iTeh STANDARD PREVIEW
(standards.iteh.ai)

ISO 4074-6:1996
Préservatifs masculins en caoutchouc —
Partie 6: Détermination du volume et de la pression d'éclatement
<https://standards.iteh.ai/catalog/standards/sist/0e0f9dc0-368c-4b55-8938-15a2646da60/iso-4074-6-1996>

INTERNATIONAL

ISO



Reference number
ISO 4074-6:1996(E)

Foreword

ISO (the International Organization for Standardization) is a worldwide federation of national standards bodies (ISO member bodies). The work of preparing International Standards is normally carried out through ISO technical committees. Each member body interested in a subject for which a technical committee has been established has the right to be represented on that committee. International organizations, governmental and non-governmental, in liaison with ISO, also take part in the work. ISO collaborates closely with the International Electrotechnical Commission (IEC) on all matters of electrotechnical standardization.

Draft International Standards adopted by the technical committees are circulated to the member bodies for voting. Publication as an International Standard requires approval by at least 75 % of the member bodies casting a vote.

International Standard ISO 4074-6 was prepared by Technical Committee ISO/TC 157, *Mechanical contraceptives*.

This third edition cancels and replaces the second edition (ISO 4074-6:1984), of which it constitutes a technical revision.

ISO 4074 consists of the following parts, under the general title *Rubber condoms*:

- Part 1: Requirements
- Part 2: Determination of length
- Part 3: Determination of width
- Part 5: Testing for holes — Water leak test
- Part 6: Determination of bursting volume and pressure
- Part 7: Oven conditioning
- Part 9: Determination of tensile properties
- Part 10: Packaging and labelling — Condoms in consumer packages

© ISO 1996

All rights reserved. Unless otherwise specified, no part of this publication may be reproduced or utilized in any form or by any means, electronic or mechanical, including photocopying and microfilm, without permission in writing from the publisher.

International Organization for Standardization
Case Postale 56 • CH-1211 Genève 20 • Switzerland

Printed in Switzerland

Annex A of this part of ISO 4074 is for information only.

iTeh STANDARD PREVIEW
(standards.iteh.ai)

ISO 4074-6:1996

<https://standards.iteh.ai/catalog/standards/sist/0e0f9dc0-368c-4b55-8938-f3aa204bda60/iso-4074-6-1996>

iTeh STANDARD PREVIEW
This page intentionally left blank
(standards.iteh.ai)

ISO 4074-6:1996

<https://standards.iteh.ai/catalog/standards/sist/0e0f9dc0-368c-4b55-8938-f3aa204bda60/iso-4074-6-1996>

Rubber condoms —

Part 6:

Determination of bursting volume and pressure

1 Scope

This part of ISO 4074 specifies the method of determining the bursting volume and pressure of rubber condoms.

2 Principle

A specified length of the condom is inflated with air and the volume of air used for inflation and the pressure at the moment of bursting are recorded.

NOTE 1 Burst volume is the volume of air that has flowed into the condom until the moment of burst.

3 Apparatus

Inflation apparatus, as shown in figure 1, suitable for inflating the condom with clean oil-free and moisture-free air at a specified rate, provided with equipment for measuring volume and pressure and having the features in 3.1 to 3.4.

If an inflation cabinet is used, it is recommended that it have a window for viewing the condom during inflation, and that it be of sufficient size to allow the condom to expand freely without touching any part of the cabinet.

3.1 Pressure gauge, capable of measuring the pressure at burst of the condom to an accuracy of $\pm 0,05$ kPa, configured such that there is no pressure

differential between the condom and the pressure gauge.

3.2 Apparatus for recording the volume of inflation air, configured such that the volume of air is measured or calculated at the appropriate pressure within the condom and not at the line pressure which may be higher.

Whatever method is used to measure volume, it shall be accurate to $\pm 0,03$ % for volumes greater than 10 dm^3 .

3.3 Rod of suitable length, having a smooth sphere or hemisphere of 25 mm in diameter at its top for hanging the unrolled condom when fixed to the apparatus, and fixed in a position such that when the condom is clamped, the length of the condom remaining for inflation is $150 \text{ mm} \pm 3 \text{ mm}$.

3.4 Clamping ring, having no sharp edges or protrusions.

The clamping ring should not stretch the condom as the clamping ring is placed onto its mount.

When used with an air-inflated cuff mount, the clamping ring should extend no more than approximately 3 mm above the air-inflated cuff, which should deflate to such a diameter that the condom freely rolls over it.

Dimensions in millimetres

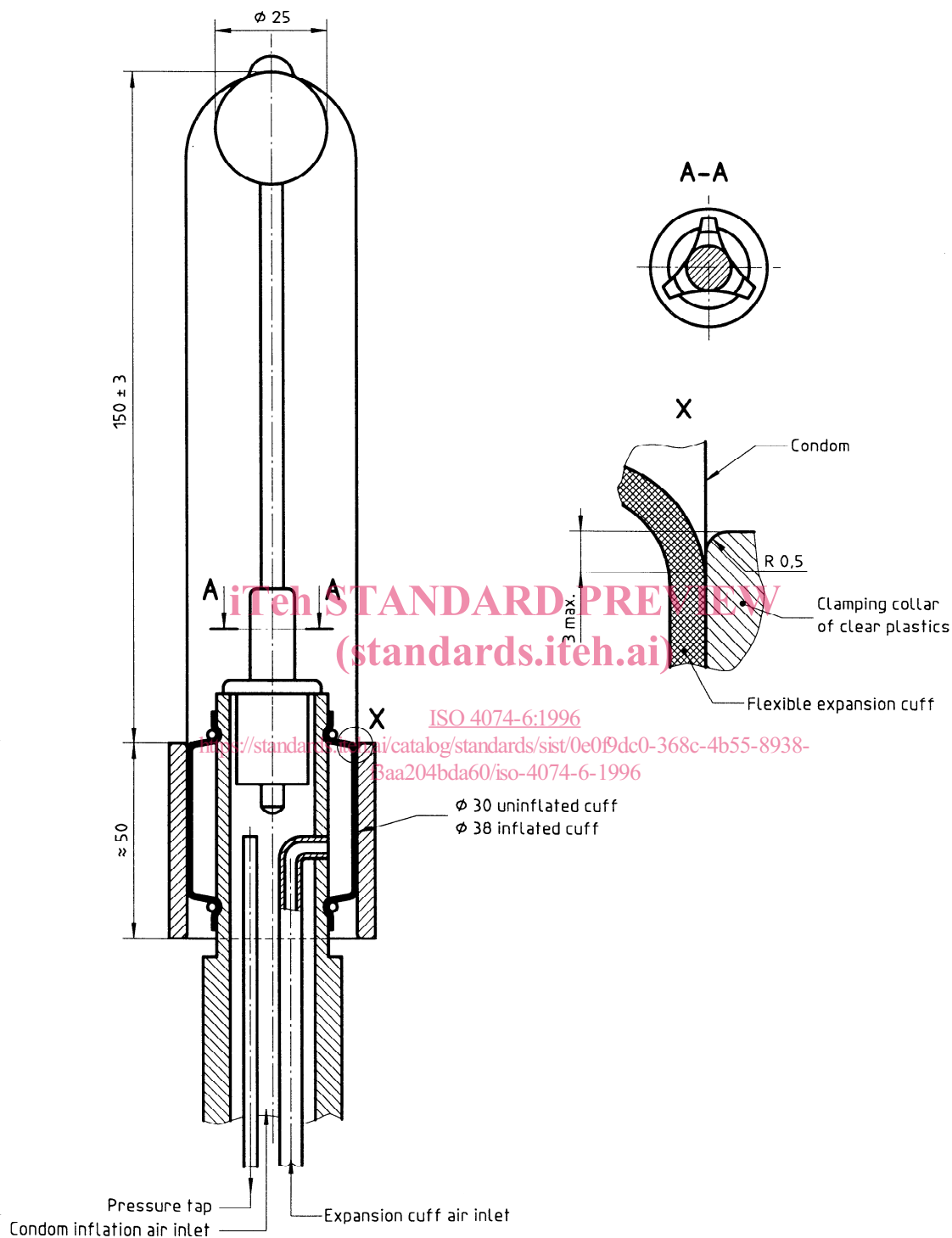

NOTE — The figure shows an example. Other types of clamps are also in use.

Figure 1 — Example of suitable apparatus

4 Procedure

4.1 Wear suitable gloves while handling the condom.

4.2 Move the condom inside the package such that it is away from the area where the package is to be torn. Tear the package and remove the condom.

In no circumstances use scissors or other sharp instruments to open the package.

4.3 Unroll the condom, ensuring that it is not excessively stretched in any direction.

NOTE 2 The condom may be unrolled directly onto the rod (3.3).

4.4 Hang the condom on the rod and fix to the mount. Inflate with air at a rate of $0,4 \text{ dm}^3/\text{s}$ to $0,5 \text{ dm}^3/\text{s}$ ($24 \text{ dm}^3/\text{min}$ to $30 \text{ dm}^3/\text{min}$). Check to ensure that the condom expands and that there are no visible leaks.

If the condom exhibits any obvious leaks or leaks are detected during the inflation, discontinue the test. The

condom is deemed to be a failure and the bursting volume and pressure are recorded as zero.

4.5 If the condom does not leak, measure and note the bursting volume, in cubic decimetres rounded to at least the nearest $0,5 \text{ dm}^3$, and the bursting pressure, in kilopascals rounded to the nearest $0,05 \text{ kPa}$.

5 Test record

The test record shall include at least the following particulars:

- a) the number of condoms tested;
- b) identification of the sample, e.g. batch number;
- c) the relevant test parameters;
- d) the bursting volume and bursting pressure of each condom tested;
- e) date of test.

ISO 4074-6:1996
<https://standards.iteh.ai/catalog/standards/sist/0e0f9dc0-368c-4b55-8938-f3aa204bda60/iso-4074-6-1996>

Annex A (informative)

Air inflation equipment for determination of bursting volume and pressure: Example of system checks and calibrations

A.1 System check algorithm

Due to the diversity of equipment used by different laboratories, it is not practical to define all calibration and verification procedures.

The steps listed in figure A.1, if performed in order, are an example of suitable system checks for verification, audit and calibration which apply to many systems. The algorithm may need to be adapted to suit individual equipment configurations. Some systems may benefit from the installation of additional equipment, such as tees, isolating valves or manual control switches, to facilitate system checking.

In-house calibrations should be done at appropriate intervals, or whenever there is a reason to doubt the reading on an instrument.

A.2 Clamp slip force check

This test ensures that the condom length does not vary significantly during inflation and consists of making a mark on a condom as close as possible to the top of the collar, inflating the condom till it is near to burst, bursting it with a pin near the reservoir, and observing whether the mark has moved.

A.3 Inflation length check

This is a measurement, either on the test head or on the length-measuring mandrel, that verifies that 150 mm of condom is being inflated, i.e. that the length limiter is properly set, that the condom is not stretched by the clamping equipment, and that it is not being blown out of position before the clamp grips.

A.4 Cuff leak check

A check that inflatable cuffs do not leak air, especially

into the condom. If the cuff and the air supply can be actuated separately, it is possible to check the cuff by turning on the air supply, isolating the cuff, and then observing it to see that it is still inflated after, say, 5 min.

A.5 Air supply leak check

A check that there are no leaks in the air supply system and the pressure-sensing system that would cause an error in the measured volume.

A.6 Pressure gauge calibration

Pressure gauges or transducers can be checked regularly against a reference meter, connected in parallel with the gauge or transducer. A convenient and accurate reference is a water-tube manometer. The whole range of pressures encountered should be checked, either by placing a variable constriction over the test head or by inflating a condom (or two, one over the other) in stages.

A.7 Air flowrate adjustment and calibration

If the system relies on timing the inflation and multiplying by the flowrate, then the flowrate needs to be known accurately; if, however, total volume is measured, it needs only to be within the stipulated range. It is advisable to set the flowrate around the centre of the allowable range, to allow for fluctuations due to ambient conditions.

Flowrate calibration is conveniently carried out using a suitable variable area flowmeter (rotameter) calibrated against a certified instrument. Rotameters are simple in construction, having few moving parts, and much of the critical equipment inside the meter is directly visible to the user. Volume meters can also be used.

The calibrating meter should be attached directly to the condom test head, where the condoms are normally mounted. Suitable stands and connecting hoses (with minimal pressure drop) may be necessary. If there is no permanent in-line meter, it is important to verify that the connection of the meter does not alter the flowrate significantly.

Changes in ambient conditions may affect the flowrate slightly, and on systems that rely on elapse of time to burst, flowrate should be checked and recalculated twice daily, and whenever there are major weather changes.

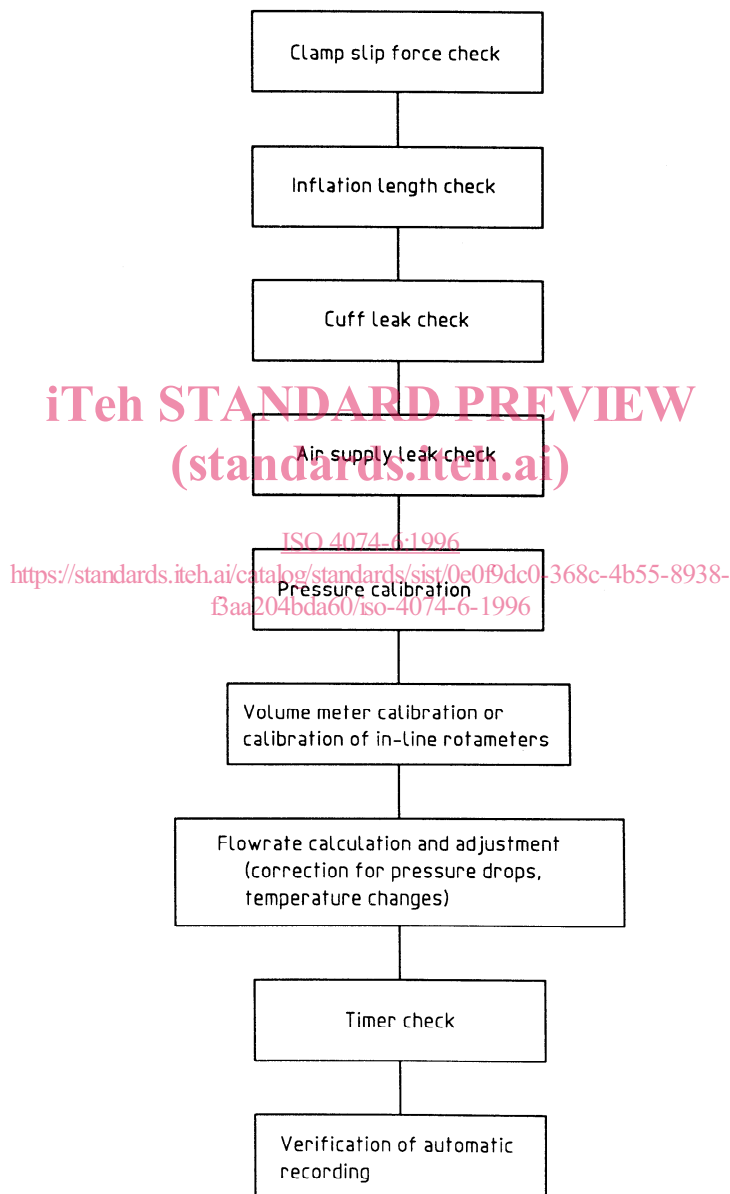

NOTE — Some items, such as elimination of leaks, are a prerequisite to others, such as calibration of volume and pressure readings, but others, such as timer checking, inflation length and verification of automatic recording, can be done independently of most other checks.

Figure A.1 — List of periodic checks