



Designation: F3186 – 17

Standard Specification for Adult Portable Bed Rails and Related Products¹

This standard is issued under the fixed designation F3186; the number immediately following the designation indicates the year of original adoption or, in the case of revision, the year of last revision. A number in parentheses indicates the year of last reappraisal. A superscript epsilon (ϵ) indicates an editorial change since the last revision or reappraisal.

1. Scope

1.1 This safety specification establishes performance requirements for adult portable bed rails, related products, and adult portable bedrail accessories, including requirements for resistance to entrapment, marking and adhered labels, instructional literature, and advertising.

1.2 This standard is applicable to any such product (as defined below) that is not designed as part of the bed by the bed manufacturer, and is installed on, against or adjacent to the side of an adult bed and is for use by adults to reduce the risk of falling from the bed, assist in repositioning in the bed, assist in transitioning into or out of the bed, or other similar purposes as stated by the manufacturer.

1.3 This safety specification includes adult portable bed rails that meet the definition of a medical device and are therefore under the jurisdiction of the Food and Drug Administration (FDA), and adult portable bed rails that are not medical devices, and which therefore fall under the jurisdiction of the Consumer Product Safety Commission (CPSC).²

1.4 This safety specification does not cover guardrails or side rails intended for use on FDA regulated hospital beds, or portable rails for children which are included in Consumer Safety Specification F1821 for toddler beds, Consumer Safety Specification F2085 for portable bed rails for children, or IEC 60601-2-52 for medical beds.

1.5 This safety specification is intended to minimize entrapment and strangulation hazards that are attributed to design components, whether these hazards arise from normal installation and use, reasonably foreseeable mis-installation/misuse, or changes to the stability of the attachment over time, or combinations thereof. Other hazards may exist (for example, falls) that are not within the scope of this specification. Such hazards will be the subject of additional standards.

1.6 No adult portable bed rail, or related product as defined in this specification, shall, either by label or other means,

¹ This specification is under the jurisdiction of ASTM Committee F15 on Consumer Products and is the direct responsibility of Subcommittee F15.70 on Adult Safety Products.

Current edition approved Aug. 1, 2017. Published August 2017. DOI: 10.1520/F3186-17.

² See “Is The Product a Medical Device?”, www.fda.gov/medicaldevices/deviceregulationandguidance/overview/classifyyourdevice/ucm051512.htm.

indicate compliance with this specification unless it conforms to all the requirements contained herein.

1.7 *Units*—The values stated in inch-pound units are to be regarded as standard. The values given in parentheses are mathematical conversion to SI units that are provided for information only and are not considered standard.

1.8 *This standard does not purport to address all of the safety concerns, if any, associated with its use. It is the responsibility of the user of this standard to establish appropriate safety, health and environmental practices and determine the applicability of regulatory limitations prior to use.*

1.9 *This international standard was developed in accordance with internationally recognized principles on standardization established in the Decision on Principles for the Development of International Standards, Guides and Recommendations issued by the World Trade Organization Technical Barriers to Trade (TBT) Committee.*

2. Referenced Documents

2.1 ASTM Standards:³

D3359 Test Methods for Rating Adhesion by Tape Test

F1821 Consumer Safety Specification for Toddler Beds

F2085 Consumer Safety Specification for Portable Bed Rails

2.2 Federal Standards and Guidelines:⁴

16 CFR 1500.48 Technical Requirements for Determining a Sharp Point in Toys and Other Articles Intended for Use by Children Under 8 Years of Age

16 CFR 1500.49 Technical Requirements for Determining a Sharp Metal or Glass Edge in Toys and Other Articles Intended for Use by Children Under 8 Years of Age

2.3 Other Standards:

IEC 60601-2-52 Medical Electrical Equipment – Part 2-52: Particular Requirements for the Basic Safety and Essential Performance of Medical Beds⁵

³ For referenced ASTM standards, visit the ASTM website, www.astm.org, or contact ASTM Customer Service at service@astm.org. For *Annual Book of ASTM Standards* volume information, refer to the standard's Document Summary page on the ASTM website.

⁴ Available from U.S. Government Printing Office, Superintendent of Documents, 732 N. Capitol St., NW, Washington, DC 20401-0001, <http://www.access.gpo.gov>.

⁵ Available from International Electrotechnical Commission (IEC), 3, rue de Varembe, 1st Floor, P.O. Box 131, CH-1211, Geneva 20, Switzerland, <http://www.iec.ch>.

ANSI Z535.4 American National Standard for Product Safety Signs and Labels⁶

3. Terminology

3.1 Definitions of Terms Specific to This Standard:

3.1.1 *adult portable bed rail, n*—an adjacent type bed rail, grab bar, assistive bar, transfer aid, cane or rail (henceforth identified as the product or products) intended by the manufacturer to be installed on, against, or adjacent to an adult bed. The product may vary in lengths (for example, full, half, or partial rails, grab bar or handle or transfer post or pole), and is intended by the manufacturer to provide assistance to the bed occupant in moving on the bed surface, in entering or exiting the bed, to minimize the possibility of falling out of bed, or for other similar purposes. This includes similar products that are likely to be used for these purposes even if this is not explicitly stated by the manufacturer. However, the standard does not address ALL products that might be so used, for example, a chair.

3.1.2 *adjacent type bed rail, n*—a portable bed rail or related product in which the guard portion (portion that an adult would contact when rolling toward the mattress edge) is essentially a vertical plane or pole that is positioned against the side of the mattress.

3.1.3 *conspicuous, adj*—visible, when the product is in the manufacturer’s recommended use position, to a person standing near the unit at any one position around the unit but not necessarily visible from all positions.

3.1.4 *consumer adjustment, n*—those activities defined by the instructions to be taken by the installer in order to properly fit and secure the product to the mattress and bed structure.

3.1.5 *hazardous condition, n*—product design or arrangement between product, mattress, and accessories that is likely to create a condition that is likely to cause death or serious personal injury to persons exposed to such conditions.

3.1.6 *mattress topper, n*—a soft cushion that sits on top or encloses a bed’s mattress that is used to make the existing mattress more comfortable and may be made of an egg crate foam, memory or visco-elastic foam, poly fibers, feathers, or other materials

3.1.7 *retention system, n*—those parts of the product that serve to keep the product in place when installed in accordance with the instructions for use.

4. Test Set-up Requirements

4.1 The product shall be completely assembled in accordance with the instructions for use, unless otherwise noted in the tests below.

4.2 No testing shall be conducted within 48 h of manufacturing.

4.3 The product to be tested shall be in a room with an ambient temperature of $73 \pm 9^\circ\text{F}$ ($23 \pm 5^\circ\text{C}$) for at least 1 h prior to testing. Testing shall then be conducted within this temperature range.

⁶ Available from American National Standards Institute (ANSI), 25 W. 43rd St., 4th Floor, New York, NY 10036, <http://www.ansi.org>.

4.4 All testing required by this specification shall be conducted on the same unit.

5. General Requirements

5.1 There shall be no hazardous sharp point or edges as defined by 16 CFR 1500.48 and 16 CFR 1500.49.

5.2 Any exposed parts shall be smooth and free from rough or jagged surfaces.

5.3 Products covered by this specification that can be installed on a bed that articulates shall meet all of the performance requirements in Section 6 when the bed is in the flat and articulated positions and shall be assessed for risk of entrapment as specified in Section 8.

6. Performance Requirements

6.1 Retention Systems:

6.1.1 All products shall include a method for maintaining the installed product in a position for which the product will continue to perform to the test methods in Section 8 without requiring readjustment of any components. Some movement of product or mattress is acceptable as long as it does not lead to failure to meet the tests in Section 8.

6.1.2 The retention system shall be permanently attached to the product, as described in 6.1.3, by the manufacturer or by the consumer during the initial assembly.

6.1.3 Permanently attached retention system components shall not be able to be removed without the use of a tool after initial installation.

6.1.4 Retention system components shall not allow the retention system to slip when tested in accordance with the entrapment tests in Section 8.

6.1.5 Straps:

6.1.5.1 Any straps used to attach the product to the bed must be shown to allow for the product to continue to meet the test requirements under the forces used for attachment and adjustment when tested in accordance with 8.6.

6.1.5.2 After initial assembly the straps shall require the use of a tool for removal.

6.2 Structural Integrity:

6.2.1 When installed using the thickest mattress recommended by the product manufacturer, the top of the product shall extend at least 4.0 in. (101.6 mm) above the top surface of the mattress.

6.2.2 After testing in accordance with 8.1 – 8.3, there shall be no changes in dimensions or hazardous condition created as defined in Section 5.

6.3 *Entrapment*—Products shall be tested with respect to each applicable Zone (Fig. 1) in accordance with Section 8. These zones are described in the cited FDA Guidance⁷ (see Appendix X1 for further details). Fig. 1 is similar to that used in the FDA Guidance. Adult portable bed rail products vary in shape, design, and use. Therefore, this figure serves as a

⁷ See Hospital Bed System Dimensional and Assessment Guidance to Reduce Entrapment (issued March 10, 2006), US Food and Drug Administration, <http://www.fda.gov/MedicalDevices/DeviceRegulationandGuidance/GuidanceDocuments/ucm072662.htm>.

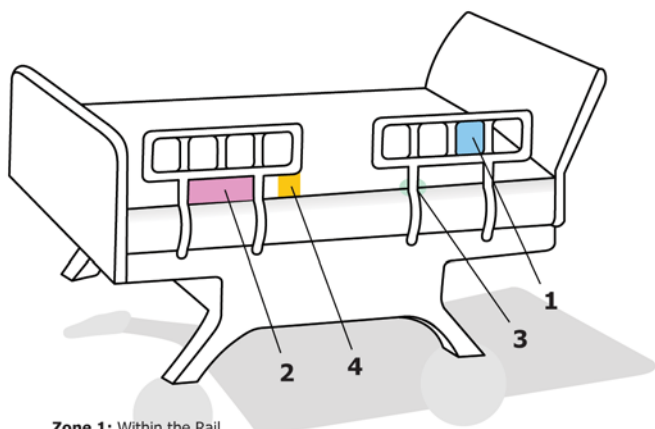

Zone 1: Within the Rail
Zone 2: Between rail support and bed mattress
Zone 3: Between rail and mattress
Zone 4: Under end of rail and mattress

NOTE 1—See FDA Guidance⁷ for further discussion of entrapment zones.

FIG. 1 Entrapment Zones

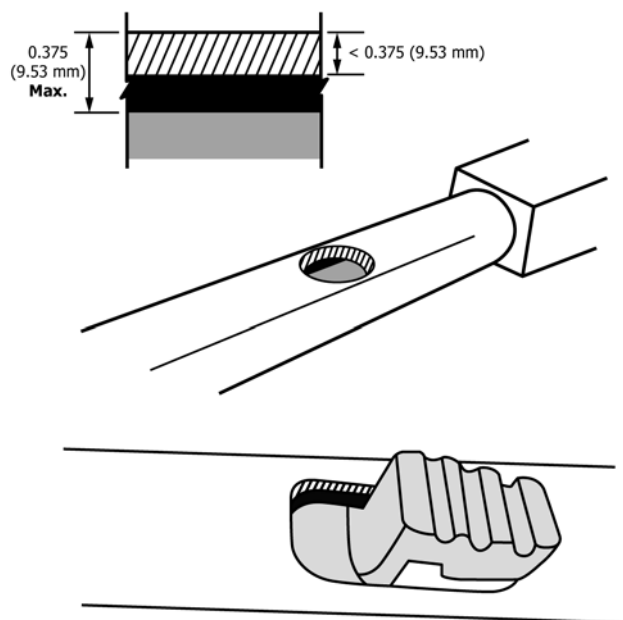

FIG. 2 Opening Example

reference for zone or areas of entrapment for a portable bed rails, but the actual shapes and sizes of products could be different from Fig. 1.

6.3.1 A bed rail type product is shown in Fig. 1. Other bed rails and products covered by this specification may not have one or more of the indicated entrapment zones and testing shall be adjusted accordingly, for example a product without penetrating openings will not have Zone 1. However, if the area represented by a zone is present, that area must pass the applicable test. Most products will have an area at each end indicated by Zone 4.

6.3.2 Zones 1–2—The test probe (see 7.2 for discussion of the test probe) shall not pass completely through the opening when tested according to 8.4.3 and 8.4.4.

6.3.3 Zone 3—The highest point on the cylinder of the test probe (see 7.2) shall not pass completely below the horizontal uncompressed plane of the mattress when tested according to 8.4.5.

6.3.4 Zone 4—The test probe shall not pass completely through the opening or touch the product in the red area of the test probe when tested according to 8.4.6.

6.4 Openings:

6.4.1 Holes or slots that extend entirely through a wall section of any rigid material less than ¼ in. (6.35 mm) thick and admit a 5/8 in. (13 mm) diameter rod shall also admit a 1 in. (25.4 mm) diameter rod. Holes or slots that are between 8 mm and 25 mm and have a wall thickness less than ¼ in. (6.35 mm) but are limited in depth to ¼ in. (6.35 mm) maximum by another rigid surface shall be permissible (see Fig. 2).

6.5 Misassembled Products:

6.5.1 Any structural components and retention system components of a product covered by this specification that requires consumer assembly shall not be able to be misassembled when evaluated to 6.5.2.

6.5.2 *Determining Misassembled Product:* A product covered by this specification shall be considered misassembled if

it appears to be functional under any condition and it does not meet the requirements of 6.1 – 6.4.

7. Test Equipment:

7.1 Test Platform:

7.1.1 *Mattress and Mattress Support*—Testing shall be conducted on each mattress and mattress support and type of bed that the manufacturer specifies as suitable for use with their product.

7.1.2 Products intended by the manufacturer to be used on articulating type bed systems shall be tested using the recommended system. Testing shall be performed with the mattress oriented in the flat position and in the articulated positions that present the greatest risk of entrapment as determined by the tester.

7.2 *Entrapment Test Probe*—The test probe shall be as described in the FDA Guidance Document “Hospital Bed System Dimensional and Assessment Guidance to Reduce Entrapment” which can be found at <http://www.fda.gov/MedicalDeviceRegulationandGuidance/GuidanceDocuments/ucm072662>. The test probe can be independently manufactured, or it can be purchased from NST Sales & Customer Service Office, 5154 Enterprise Blvd., Toledo, Ohio 43612, 800-678-7072, www.nst-usa.com.⁸ A video illustrating use of the test probe is available at the NST website (free registration required).

7.3 *Force Gauge*—The force gauge of the test probe shall have a minimum range of 0 to 50 lbf (222.5 N) with a maximum tolerance of ±0.25 lbf (1.11 N).

⁸ The sole source of supply of the apparatus known to the committee at this time is Bionix Safety Technologies. If you are aware of alternative suppliers, please provide this information to ASTM International Headquarters. Your comments will receive careful consideration at a meeting of the responsible technical committee,¹ which you may attend.

8. Test Requirements and Methods

8.1 All products shall be tested fully assembled in accordance with the manufacturer’s instructions.

8.1.1 All tests in this section shall be performed sequentially.

8.1.2 Adjustments may be made between tests to realign product with mattress provided that any movement shall not have caused the product to fail the prior test.

8.2 Products provided with accessories shall be tested in positions that create the greatest risk of entrapment. Such testing shall be done with and without supplied accessories installed unless accessories are intended as a functional part of the product by the manufacturer and require use of a tool for removal.

8.3 Test Method for Structural Integrity of Product:

8.3.1 Product shall be secured to a rigid, smooth surface in the same orientation as it would be installed on a bed. Adjustments may be made to test equipment securing the product to the test platform between tests. Product component adjustments shall not be performed between load tests.

8.3.2 Apply a force of 22.5 lbf (100 N) perpendicular to the top middle section of the product in the direction of E (Fig. 3). Apply the force in the reverse direction, D (Fig. 3). Repeat for 500 cycles.

8.3.3 Apply a force of 22.5 lbf (100 N) lengthwise on the product in the direction indicated by C. Apply the force in the reverse direction, B (Fig. 3). Repeat for 500 cycles and at each end.

8.3.4 Apply a force of 22.5 lbf (100 N) on the uppermost part of the product in the vertical direction indicated by A (Fig. 3). Repeat for 500 cycles.

8.4 Entrapment Tests:

NOTE 1—The tests described in this section are identical to those

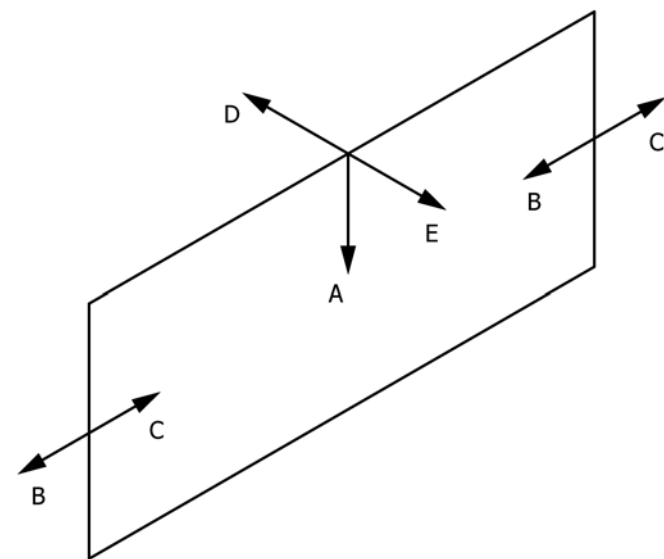

NOTE 1—Forces are applied at the locations most likely to result in failure.

FIG. 3 Structural Integrity

described in the referenced FDA Guidance Document⁷ and in the NSA video.

8.4.1 The test probe safety strap should be attached to the test probe and attached to the rail prior to testing to avoid injury and ensure that the strap does not interfere with testing. Ensure that the strap is short enough to keep the tool from injuring your feet if it falls and long enough so it does not interfere with the test being performed.

8.4.2 Any component provided with the product that can be removed without the use of a tool shall be removed prior to testing.

8.4.3 Zone 1 (Fig. 1), Within the Product:

8.4.3.1 This test requires the use of a force gauge and the cone portion of the test probe.

8.4.3.2 Determine the largest opening within the product.

8.4.3.3 Insert the 2.4 in. (60 mm) end of the entrapment test cone perpendicular to the opening until it is in full contact with the product.

8.4.3.4 If the test probe does not pull through freely attach the force gauge and exert a 22.5 lbf (100 N) pulling force to the 2.4 in. (60 mm) cylindrical end of the entrapment test tool perpendicular to the plane of the opening in both directions. If the 4.7 in. (120 mm) end of the cone does not enter any of the openings, this space passes the test. If the 4.7 in. (120 mm) end of the test probe cone does enter and pass through any of the openings, this space fails the test.

8.4.4 Zone 2 (Fig. 1), Between the Product Support(s) and the Bed Mattress, When Applicable, Under the Product:

8.4.4.1 This test requires the use of a force gauge and the cone portion of the test probe.

8.4.4.2 Determine the largest opening between the product support(s), bottom of the product and the mattress.

8.4.4.3 Insert the 2.4 in. (60 mm) end of the cone perpendicular to the opening from the longitudinal centerline of the mattress. Slide the cone into the opening until it is in full contact with the product. The mattress shall only be compressed by the weight of the cone.

8.4.4.4 Using the force gauge, exert a 22.5 lbf (100 N) pulling force to the 2.4 in. (60 mm) cylindrical end of cone in both directions perpendicular to the rail.

(1) If the 4.7 in. (120 mm) end of the cone does not enter the space under the product, or pass under the product, this space passes the test.

(2) If the 4.7 in. (120 mm) end of the cone does enter the space under the product, and pass under the product, this space fails the test.

8.4.5 Zone 3 (Fig. 1), Between the Product and the Mattress:

8.4.5.1 This test requires the use of the cone portion of the test probe.

8.4.5.2 Orient the cone centerline along the longitudinal line of the mattress.

8.4.5.3 Gently place the cone into the gap between the product and mattress.

8.4.5.4 Turn the cone until the line on the face of the 4.7 in. (120 mm) end is horizontal and let the cone sink into the space by its own weight.