

INTERNATIONAL STANDARD

IEC
60335-2-69

2002

AMENDMENT 1
2004-11

Amendment 1

**Household and similar electrical appliances –
Safety –**

**Part 2-69:
Particular requirements for wet and dry
vacuum cleaners, including power brush,
for industrial and commercial use**

<https://standards.iteh.ai/catalog/standards/iec/86748e1e-ec2f-43c8-b5a2-327ccc962224/iec-60335-2-69-2002/amd1:2004>

© IEC 2004 Droits de reproduction réservés — Copyright - all rights reserved

International Electrotechnical Commission, 3, rue de Varembé, PO Box 131, CH-1211 Geneva 20, Switzerland
Telephone: +41 22 919 02 11 Telefax: +41 22 919 03 00 E-mail: inmail@iec.ch Web: www.iec.ch



Commission Electrotechnique Internationale
International Electrotechnical Commission
Международная Электротехническая Комиссия

FOREWORD

This amendment has been prepared by subcommittee 61J: Electrical motor-operated cleaning appliances for industrial use, of IEC technical committee 61: Safety of household and similar electrical appliances.

The text of this amendment is based on the following documents:

FDIS	Report on voting
61J/169/FDIS	61J/172/RVD

Full information on the voting for the approval of this amendment can be found in the report on voting indicated in the above table.

The committee has decided that the contents of this amendment and the base publication will remain unchanged until the maintenance result date indicated on the IEC web site under "<http://webstore.iec.ch>" in the data related to the specific publication. At this date, the publication will be

- reconfirmed,
- withdrawn,
- replaced by a revised edition, or
- amended.

CONTENTS

Add the titles of the new Annexes CC and DD as follows:

Annex CC (normative) Particular requirements for vacuum cleaners, suction sweeping machines and dust extractors for the collection of dusts which are an explosion risk

Annex DD (normative) Particular requirements for vacuum cleaners for use in ESD protected areas

Add the titles of the following new figures:

Figure 102 – Apparatus for testing the abrasion resistance of current-carrying hoses

Figure 103 – Apparatus for testing the resistance to flexing of current-carrying hoses

Figure 104 – Configuration of the hose for the freezing treatment

Figure 105 – Flexing positions for the hose after removal from the freezing cabinet

Figure AA.2 – Test method for essential filter material

Figure AA.3 – *In situ* essential filter element test

Figure AA.4 – Assembled appliance test

Figure CC.1 – Marking – Type 22 vacuum cleaners and suction sweeping machines

Figure CC.2 – Marking – Type 22 dust extractor

Replace the title of Table AA.1 as follows:

Table AA.1 – Penetration limits

FOREWORD

Add the following new item to the list of differences existing in some countries:

- 7.12: No requirements for sound marking exist (USA)

2 Normative references

Add the following new references:

IEC 60704-2-1, *Household and similar electrical appliances – Test code for the determination of airborne acoustical noise – Part 2-1: Particular requirements for vacuum cleaners*

IEC 61241-1-1, *Electrical apparatus for use in the presence of combustible dust – Part 1-1: Electrical apparatus protected by enclosures and surface temperature limitation – Specification for apparatus*

IEC 61241-10:2004, *Electrical apparatus for use in the presence of combustible dust – Part 10: Classification of areas where combustible dusts are or may be present*

ISO 2602, *Ergonomics – Danger signals for public and work areas – Auditory danger signals*

ISO 6344-2, *Coated abrasives – Grain size analysis – Part 2: Determination of grain size distribution of macrogrits P12 to P220*

ISO 7731, *Safety of machinery; Auditory danger signals; General requirements, design and testing*

ISO 11428, *Ergonomics – Visual danger signals – General requirements, design and testing*

3 Definitions

Add the following new definitions:

3.102

water-suction cleaning appliance

appliance for aspirating an aqueous solution that may contain foaming detergent

3.103

motorized cleaning head

accessory containing a motor that is supplied from the appliance and which is attached to the end of a hand-held hose or tube

NOTE The main cleaning head permanently attached is not regarded as a motorized cleaning head.

6 Classification

6.1 Replace the existing second paragraph of this subclause with the following:

Metal parts that may continuously contact the body shall be considered as handles for which 22.36 applies.

7 Marking and instructions

7.1 *Delete this subclause.*

Add the following subclause:

7.6 *Addition:*

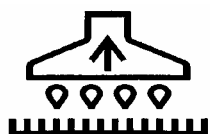

[symbol IEC 60417-5935 (DB:2000-10) motorized cleaning head for water-suction cleaning]

7.12 *Replace the existing text of the addition by the following:*

The front cover of the instruction manual shall include the substance of the following:

CAUTION Read the instruction manual before using the appliance.

This wording may be replaced by symbols ISO 7000-0434A/B and ISO 7000-1641 (DB:2004:01). If these symbols are used, their meaning is to be explained in the instructions for use.

The instruction manual shall include the substance of the following warnings, as applicable.

- CAUTION This appliance is not suitable for picking up hazardous dust.
- CAUTION This appliance is for dry use only and is not to be used or stored outdoors in wet conditions.
- WARNING Only use the brushes provided with the appliance or those specified in the instruction manual. The use of other brushes may impair safety.

The instruction manual shall give details regarding the following, as applicable:

- the precautions to be taken when using the appliance under specific conditions such as handling flammable liquids or dust and dust hazardous to health;
- a statement that the appliance is to be disconnected from its power source during cleaning or maintenance, and that when replacing parts or converting the appliance to another function:
 - for mains operated appliances, the plug is to be removed from the socket-outlet;
 - for battery operated appliances, the key of the supply switch is to be removed or an equivalent disconnection is to be made;
- the intended use of brushes which are specified for the appliance.

The instruction manual shall state the A-weighted sound pressure level L_{PA} in dB(A) emitted by the appliance. If the A-weighted sound pressure level exceeds 85 dB(A), it shall also state the sound power level L_{WA} in dB(A) and that appropriate ear protection has to be used (the sound level is measured in accordance with IEC 60704-2-1).

The instruction manual shall include the substance of the following.

This appliance is suitable for commercial use, for example in hotels, schools, hospitals, factories, shops, offices and rental businesses.

The instruction manual for mains operated appliances shall include the substance of the following:

- do not allow the rotating brushes to come into contact with the supply cord;
- regularly examine the supply cord for damage, such as cracking or ageing. If damage is found, replace the cord before further use;
- only replace the supply cord with the type specified in the instruction manual;
- only use the socket outlet on the appliance for purposes specified in the instruction manual.

For wet suction appliances, the instruction manual shall state the substance of the following:

- CAUTION If foam or liquid escapes from the appliance, switch off immediately.
- regularly clean the water level limiting device in accordance with the instructions and examine it for signs of damage.

The instructions for appliances having a current-carrying hose operating at other than **safety extra-low voltage** shall include the substance of the following:

CAUTION: This hose contains electrical connections:

- do not use to collect water;
- do not immerse in water for cleaning;
- the hose should be checked regularly and shall not be used if damaged.

If symbol IEC 60417-5935 is used, its meaning shall be explained.

Add the following subclauses:

7.14 Addition:

The height of symbol IEC 60417-5935 shall be at least 15 mm.

Compliance is checked by measurement.

7.101 Motorized cleaning heads shall be marked with

- **rated voltage** or **rated voltage range** in volts;
- **rated power input** in watts;
- name, trade mark or identification mark of the manufacturer or responsible vendor;
- model or type reference.

Motorized cleaning heads for water-suction cleaning appliances, except those of **class III construction** having a **working voltage** up to 24 V shall be marked with symbol IEC 60417-5935.

NOTE This symbol is an information sign and, except for the colours, the rules of ISO 3864 apply.

Compliance is checked by inspection.

7.102 Appliance outlets for accessories shall be marked with the maximum load in watts.

NOTE This marking may be on the appliance close to the appliance outlet.

Compliance is checked by inspection.

10 Power input and current

Add the following subclause:

10.1 Addition:

The power input of **motorized cleaning heads** is measured separately.

15 Moisture resistance

15.2 Replace the text after note 101 by the following:

Nozzles and **motorized cleaning heads of water-suction cleaning appliances** are placed in a container, the base of which is level with the surface supporting the appliance. The container is filled with a detergent solution to a level of 5 mm above its base, this level being maintained throughout the test.

The solution consists of 20 g of NaCl and 1 ml of a solution of 28 % by mass of dodecyl sodium sulphate in each 8 l of water.

The appliance is operated until its liquid container is completely full and for a further 5 min.

NOTE 102 The solution should be stored in a cool atmosphere and used within seven days of its preparation.

NOTE 103 The chemical designation of dodecyl sodium sulphate is $C_{12}H_{25}NaSO_4$.

NOTE 104 If it is not possible to overfill the container for soiled liquid owing to the construction of the appliance, the test specified in 19.101 is considered to be adequate.

After each of these tests, the appliance shall withstand the electric strength test of 16.3.

Inspection shall show that there is no trace of liquid on insulation that could result in a reduction of **clearances** or **creepage distances** below the values specified in Clause 29.

NOTE 105 The appliance is allowed to stand in normal test room atmosphere for 24h before being subjected to the test of 15.3

Add the following subclause.

15.101 Motorized cleaning heads of water suction cleaning appliances shall be resistant to liquids that may come into contact with them.

Compliance is checked by the following tests.

The **motorized cleaning head** is subjected to an impact test as described in IEC 60068-2-75, the value of the impact being 2 J. The **motorized cleaning head** is rigidly supported and three blows are applied to every point of the enclosure that is likely to be weak.

It is then subjected to the free fall test procedure 1 of IEC 60068-2-32. It is dropped 4 000 times from a height of 100 mm onto a steel plate having a thickness of not less than 15 mm. It is dropped

- 1000 times on its right side;
- 1000 times on its left side;
- 1000 times on its front face;
- 1000 times on its cleaning surface.

The **motorized cleaning head** is then subjected to the test described in 14.2.7 of IEC 60529, the water containing approximately 1 % NaCl.

The **motorized cleaning head** shall then withstand the electric strength test of 16.3, the voltage being applied between the **live parts** and the solution, and inspection shall show that there is no trace of saline solution on insulation which could result in a reduction of **clearances** and **creepage distances** below the values specified in Clause 29.

NOTE The test is not carried out on **motorized cleaning heads** of **class III construction** having a **working voltage** up to 24 V.

16 Leakage current and electric strength

Add the following subclause:

16.3 Addition:

Current-carrying hoses, except for their electrical connections, are immersed for 1 h in water containing approximately 1 % NaCl, at a temperature of $20\text{ °C} \pm 5\text{ °C}$. While the hose is still immersed, a voltage of 2 000 V is applied for 5 min between each conductor and all the other conductors connected together. A voltage of 3 000 V is then applied for 1 min between all the conductors and the saline solution.

19 Abnormal operation

19.1 Add the following new paragraph:

The test of 19.7 is only carried out on **motorized cleaning heads**.

19.7 Replace the existing text with the following:

Motorized cleaning heads are tested with the rotating brush or similar device locked for 30 s.

20 Stability and mechanical hazards

Add the following subclauses:

20.1 Addition:

NOTE 101 **Motorized cleaning heads** are not subjected to this test.

20.101 Shaft ends and similar rotating parts shall be protected if they protrude by more than a quarter of their diameter, unless the end is rounded and less than 50 mm in length.

Injury due to unintentional closing or slamming of parts, such as movable side walls and covers, shall be prevented.

Wheels or rollers for the transport of appliances heavier than 20 kg shall be located or protected so that injury to the feet of the operator is prevented.

Compliance is checked by inspection, by measurement and by manual test.

21 Mechanical strength

Add the following new subclauses:

21.102 Current-carrying hoses shall be resistant to crushing.

Compliance is checked by the following test.

The hose is placed between two parallel steel plates each having a length of 100 mm, a width of 50 mm and the edges of the longer sides rounded with a radius of 1 mm. The axis of the hose is positioned at right angles to the longer sides of the plates. The plates are placed at a distance of approximately 350 mm from one end of the hose.

The steel plates are pressed together at a rate of 50 mm/min \pm 5 mm/min until the applied force is 1,5 kN. The force is then released and the electric strength test of 16.3 is carried out between the conductors connected together and the saline solution.

21.103 Current-carrying hoses shall be resistant to abrasion.

Compliance is checked by the following test.

One end of the hose is attached to the connecting rod of the crank mechanism shown in Figure 102. The crank rotates at 30 revolutions per minute resulting in the end of the hose moving horizontally backwards and forwards over a distance of 300 mm.

The hose is supported by a rotating smooth roller over which a belt of abrasive cloth moves at a speed of 0,1 m/min. The abrasive is corundum grit size P 100, as specified in ISO 6344-2.

A mass of 1 kg is suspended from the other end of the hose, which is guided to avoid rotation.

In the lowest position, the mass has a maximum distance of 600 mm from the centre of the roller.

The test is carried out for 100 revolutions of the crank.

After the test, **basic insulation** shall not be exposed and the electric strength test of 16.3 is carried out between the conductors connected together and the saline solution.

21.104 Current-carrying hoses shall be resistant to flexing.

Compliance is checked by the following test.

The end of the hose intended to be connected to the **motorized cleaning head** is attached to the pivoting arm of the test equipment shown in Figure 103. The distance between the pivot axis of the arm and the point where the hose enters the rigid part is 300 mm \pm 5 mm. The arm can be raised from the horizontal position by an angle of 40° \pm 1°. A mass of 5 kg is suspended from the other end of the hose or from a convenient point along the hose so that when the arm is in the horizontal position the mass is supported and there is no tension on the hose.

NOTE 1 It may be necessary to reposition the mass during the test.

The mass slides against an inclined plate so that the maximum deflection of the hose is 3°.

The arm is raised and lowered by means of a crank that rotates at a speed of 10 \pm 1 r/min.

The test is carried out for 2 500 revolutions of the crank after which the fixed end of the hose is turned through 90° and the test continued for a further 2 500 revolutions. The test is repeated in each of the other two 90° positions.

NOTE 2 If the hose ruptures before 10 000 revolutions of the crank, the flexing is terminated.

After the test, the hose shall withstand the electric strength test of 16.3.

21.105 Current-carrying hoses shall be resistant to torsion.

Compliance is checked by the following test.

One end of the hose is held in a horizontal position with the remainder of the hose freely suspended. The free end is rotated in cycles, each cycle consisting of five turns in one direction and five turns in the opposite direction, at a rate of 10 turns per minute.

The test is carried out for 2 000 cycles.

After the test, the hose shall withstand the electric strength test of 16.3 and shall not be damaged to such an extent that compliance with this standard is impaired.

21.106 Current-carrying hoses shall be resistant to cold conditions.

Compliance is checked by the following test.

A 600 mm length of hose is bent as shown in Figure 104 and the ends are tied together over a length of 25 mm. The hose is then placed for 2 h in a cabinet having a temperature of $-15\text{ °C} \pm 2\text{ °C}$. Immediately after the hose is removed from the cabinet it is flexed three times, as shown in Figure 104, at a rate of one flexing per second.

The test is carried out three times.

There shall be no cracks or breaks in the hose and it shall withstand the electric strength test of 16.3.

NOTE Any discoloration is neglected.

24 Components

Add the following subclause:

24.2 Addition:

For appliances worn on the body in normal use, a remote switching device may be located at the end of an **interconnecting cord**, when the switching device cannot come into contact with the floor when the appliance is worn on the user.

The strain relieves on both sides of the **interconnecting cord** shall comply with 25.15.

25 Supply connection and external flexible cords

Add the following subclause:

25.23 Addition:

NOTE 101 There is no limitation on the length of conductors in flexible hoses.

Dimensions in millimetres

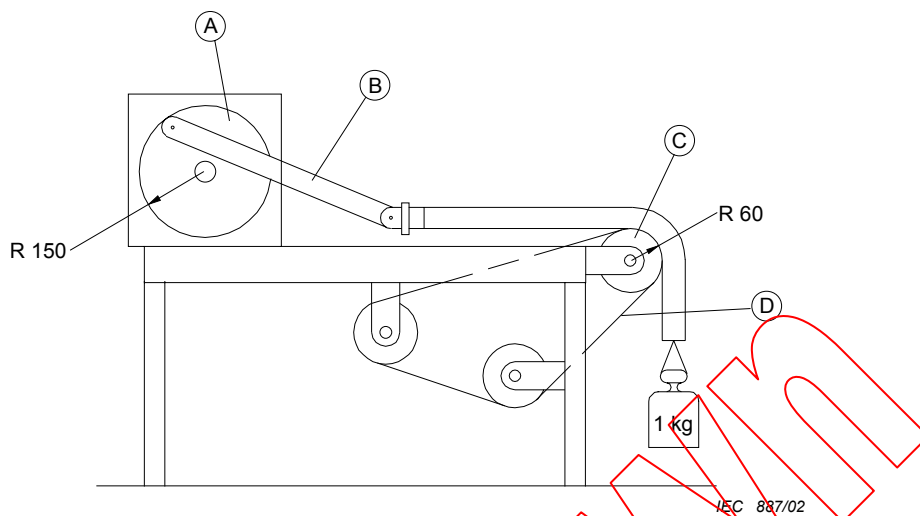

Key

- A Crank mechanism
- B Connecting rod
- C Roller, diameter 120 mm
- D Abrasive cloth belt

Figure 102 – Apparatus for testing the abrasion resistance of current-carrying hoses

Dimensions in millimetres

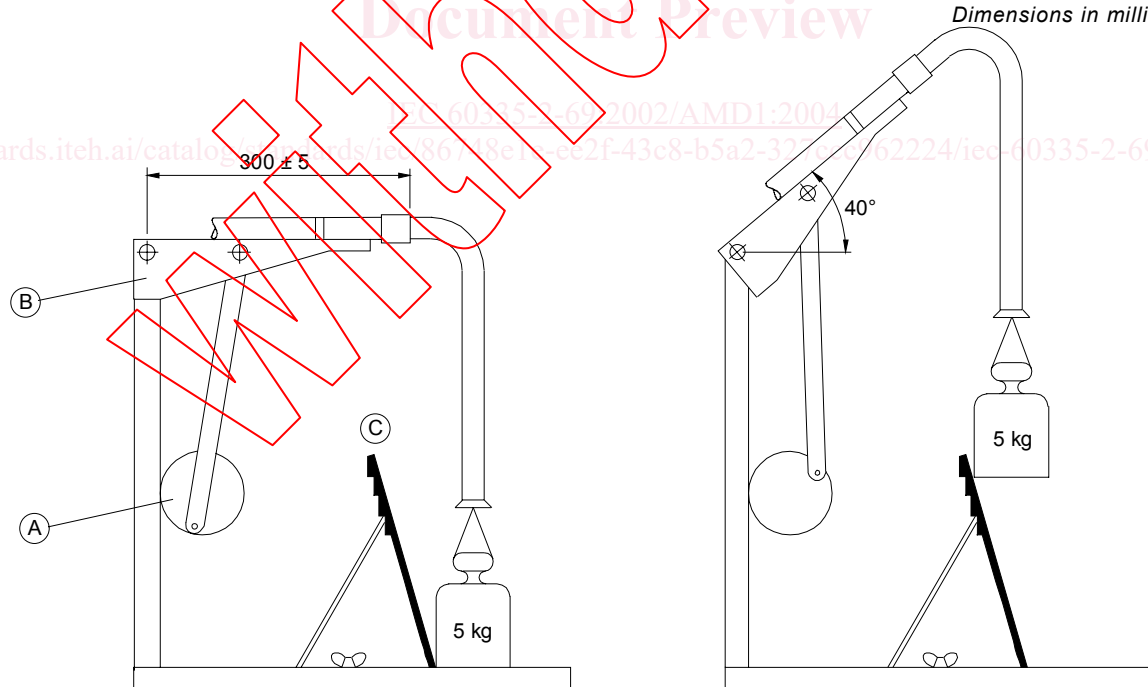

Key

- A Crank mechanism
- B Arm
- C Inclined plane

Figure 103 – Apparatus for testing the resistance to flexing of current-carrying hoses

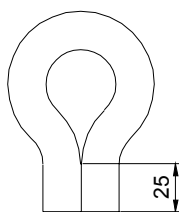
Dimensions in millimetres

IEC 889/02

Figure 104 – Configuration of the hose for the freezing treatment

Intermediate position

Position of the hose at start
and finish of each flexing

IEC 890/02

Figure 105 – Flexing positions for the hose after removal from the freezing cabinet