



Designation: G 142 – 98

# Standard Test Method for Determination of Susceptibility of Metals to Embrittlement in Hydrogen Containing Environments at High Pressure, High Temperature, or Both<sup>1</sup>

This standard is issued under the fixed designation G 142; the number immediately following the designation indicates the year of original adoption or, in the case of revision, the year of last revision. A number in parentheses indicates the year of last reapproval. A superscript epsilon ( $\epsilon$ ) indicates an editorial change since the last revision or reapproval.

## 1. Scope

1.1 This test method covers a procedure for determination of tensile properties of metals in high pressure or high temperature, or both, gaseous hydrogen-containing environments. It includes accommodations for the testing of either smooth or notched specimens.

1.2 This applies to all materials and product forms including, but not restricted to, wrought and cast materials.

1.3 The values stated in SI units are to be regarded as the standard.

1.4 *This standard does not purport to address all of the safety concerns, if any, associated with its use. It is the responsibility of the user of this standard to establish appropriate safety and health practices and determine the applicability of regulatory limitations prior to use. See 6.1 for additional information.*

## 2. Referenced Documents

### 2.1 ASTM Standards:

D 1193 Specification for Reagent Water<sup>2</sup>

E 4 Practices for Force Verification of Testing Machines<sup>3</sup>

E 8 Test Methods for Tension Testing of Metallic Materials<sup>3</sup>

E 691 Practice for Conducting an Interlaboratory Study to Determine the Precision of a Test Method<sup>4</sup>

G 15 Terminology Relating to Corrosion and Corrosion Testing<sup>5</sup>

G 111 Guide for Corrosion Tests in High Temperature or High Pressure Environment, or Both<sup>5</sup>

G 129 Practice for Slow Strain Rate Testing to Evaluate the Susceptibility of Metallic Materials to Environmentally Assisted Cracking<sup>5</sup>

### 2.2 Military Standard:

MIL-P-27201B Propellant, Hydrogen<sup>6</sup>

## 3. Terminology

### 3.1 Definitions:

3.1.1 *control test, n*—a mechanical test conducted in an environment that does not produce embrittlement of a test material.

3.1.2 *hydrogen embrittlement, n*—hydrogen induced cracking or severe loss of ductility caused by the presence of hydrogen in the metal.

3.1.3 Other definitions and terminology related to testing can be found in Terminology G 15.

## 4. Summary of Test Method

4.1 Specimens of selected materials are exposed to a gaseous hydrogen containing environment at high pressure or high temperature, or both, while being pulled to failure in uniaxial tension. The susceptibility to hydrogen embrittlement is evaluated through the determination of standard mechanical properties in tension (that is, yield strength, ultimate tensile strength, notched tensile strength, reduction in area or elongation, or both). Comparison of these mechanical properties determined in a hydrogen-containing environment to those determined in a non-embrittling environment (control test) provides a general index of susceptibility to cracking versus the material's normal mechanical behavior.

## 5. Significance and Use

5.1 This test method provides a reliable prediction of the resistance or susceptibility, or both, to loss of material strength and ductility as a result of exposure to hydrogen-containing gaseous environments. This test method is applicable over a broad range of pressures, temperatures, and gaseous environments. The results from this test method can be used to evaluate the effects of material composition, processing, and heat treatment as well as the effects of changes in environment composition, temperature, and pressure. These results may or

<sup>1</sup> This test method is under the jurisdiction of ASTM Committee G-1 on Corrosion of Metals and is the direct responsibility of Subcommittee G01.06 on Stress Corrosion Cracking and Corrosion Fatigue.

Current edition approved April 10, 1998. Published September 1998. Originally published as G 142-96. Last previous edition G 142-96.

<sup>2</sup> *Annual Book of ASTM Standards*, Vol 11.01.

<sup>3</sup> *Annual Book of ASTM Standards*, Vol 03.01.

<sup>4</sup> *Annual Book of ASTM Standards*, Vol 14.02.

<sup>5</sup> *Annual Book of ASTM Standards*, Vol 03.02.

<sup>6</sup> Available from Standardization Documents, Order Desk, Bldg. 4 Section D, 700 Robbins Ave., Philadelphia, PA 19111-5094, Attn: NPODS.

may not correlate with service experience for particular applications. Furthermore, this test method may not be suitable for the evaluation of high temperature hydrogen attack in steels unless suitable exposure time at the test conditions has taken place prior to the initiation of tensile testing to allow for the development of internal blistering, decarburization or cracking, or both.

## 6. Apparatus

6.1 Since this test method is intended to be conducted at high pressures and may also involve high temperatures, the apparatus must be constructed to safely contain the test environment while being resistant to the embrittling effects of hydrogen. Secondly, the test apparatus must be capable of allowing introduction of the test gas, removal of air from the test cell, and accurate performance of the tension test on the test specimen. In cases where the tests are conducted at elevated temperatures, the apparatus must provide for heating of the specimen and the test environment in direct contact with the specimen.

6.2 Fig. 1 shows a schematic representation of a typical test cell designed to conduct HP/HT gaseous hydrogen embrittlement experiments.<sup>7</sup> The typical components include:

6.2.1 *Metal Test Cell*—The test cell should be constructed from materials that have proven to have high resistance to hydrogen embrittlement under the conditions. A list of potential materials of construction is shown in Fig. 2.<sup>8</sup> Materials with high values of tensile ratios (environment versus a control

environment) should be used. Materials with low values of this parameter should be avoided.

6.2.2 *Closure and Seal*—To facilitate operation of the test cell and tension testing, the closure should provide for rapid opening and closing of the test cell and reliable sealing capabilities for hydrogen. This can include either metallic or non-metallic materials with high resistance to hydrogen embrittlement and degradation.

6.2.3 *Gas Port(s)*—The gas port should be designed to promote flow and circulation of the gaseous test environments, inert gas purging and evacuation as required to produce the intended test environment. Usually two ports are used so that flow-through capabilities are attained to facilitate these functions.

6.2.4 *Electrical Feed-Throughs*—If very high temperature conditions are required it may be advantageous to utilize an internal heater to heat the test specimen and the gaseous environment in the immediate vicinity of the specimen. Therefore, a feed-through would be needed to reach an internal resistance or induction heater. These feed-throughs must also provide electrical isolation from the test cell and internal fixtures, and maintain a seal to prevent leakage of the test environment. If external heaters are used, no electric feed-throughs would be required for testing.

6.2.5 *Tensile Feed-Through(s)*—To apply tensile loading to the test specimen it is necessary to have feed-through(s) which provide linear motion and transmission of loads from an external source. Care must be taken to design such feed-throughs to have low friction to minimize errors due to friction losses when using externally applied loads. These are usually designed to incorporate thermoplastic or elastomeric materials, or both. If elevated temperature tests are being conducted, then

<sup>7</sup> R. D. Kane, "High Temperature and High Pressure", *Corrosion Tests and Standards*, Ed. Robert Baboian, ASTM, West Conshohocken, PA.

<sup>8</sup> *Metals Handbook, Vol 9, Corrosion*, 9th Edition, ASM International, Metals Park, OH, 1987, p. 1104.

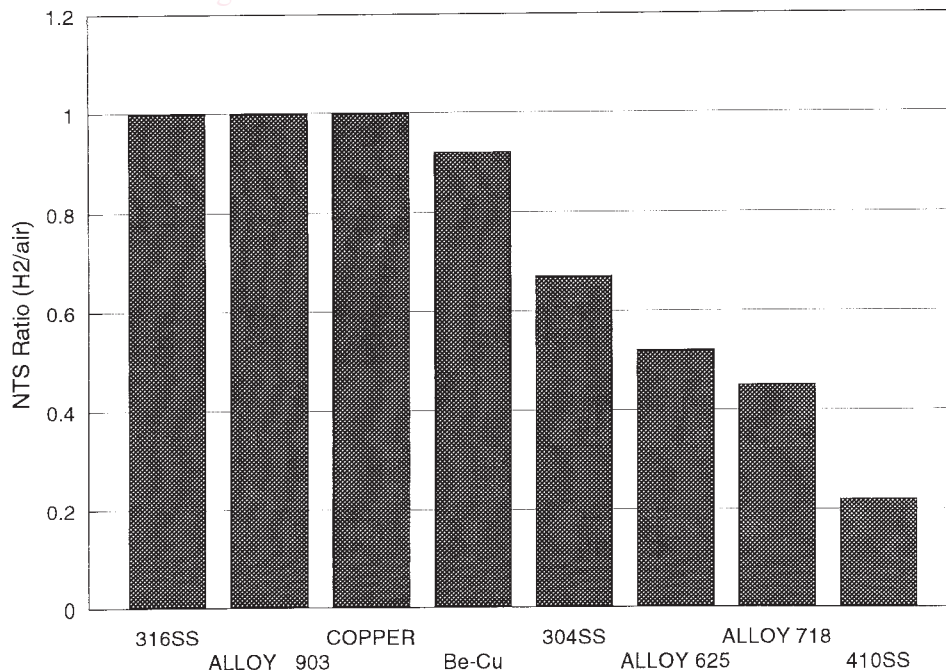

**FIG. 2 Notched Tensile Strength (NTS) Ratio for Various Alloys in 35 to 69 MPa Gaseous Hydrogen versus Air Tested at Room Temperature**

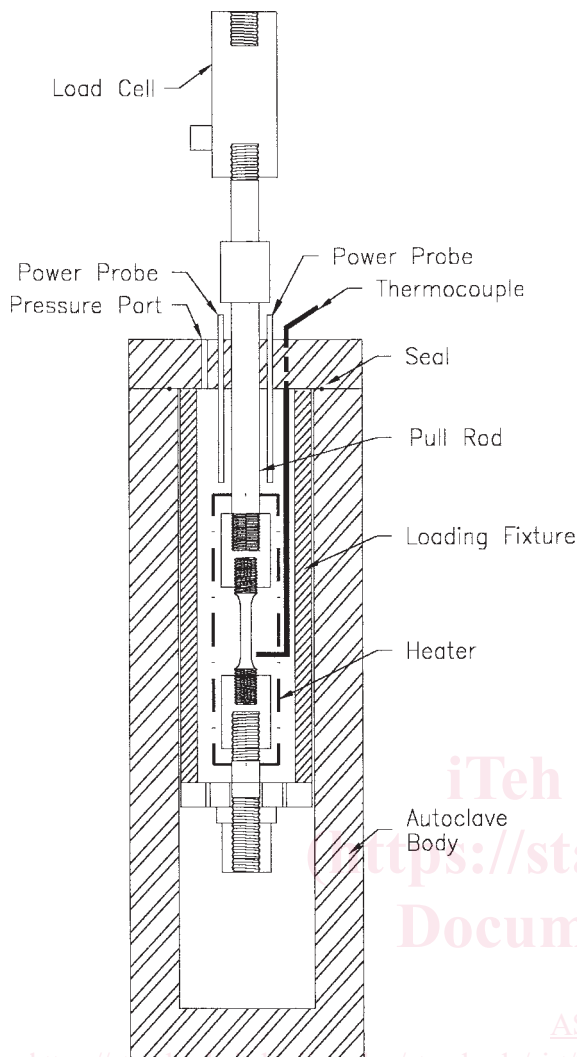

(CDN10127)

FIG. 1 Hydrogen Tensions Test Autoclave for Various Alloys in Hydrogen versus Air

extreme care must be used in the selection of these materials to also resist deterioration and loss of mechanical properties at the test temperature.

6.2.6 *Pull Rod*—The pull rod works in combination with the tensile feed-through to provide for loading of the test specimen. It is usually attached to a tensile testing machine on one end and the tension specimen on the other. It should be designed to have adequate cross-sectional area to minimize compliance in the loading system under the anticipated loads to be used. Also, to minimize frictional forces in the seal and promote sealing, it should be made with a highly polished surfaces [ $<0.25 \mu\text{m}$  (10  $\mu\text{in.}$ ) RMS]. It is possible to obtain pull rod systems that are pressure balanced so specimen loading from the internal pressure in the test cell can be minimized.

6.2.7 *Load Cell*—Load cells for conducting high pressure tensile tests may be two configurations:

6.2.7.1 External load cells which are attached to the pull rod outside of the test cell, and

6.2.7.2 Internal load cells which are either attached to the pull rod or grip assembly inside of the autoclave or are integrated into the pull rod. When using external load cells it is important to correct load cell readings for frictional forces in the pressure seal. Additionally, if non-pressure balanced pull rods are used, compensation for pressure loading of the specimen must be also performed.

6.2.8 *Electric Resistance or Induction Heater(s)*—Either internal or external heaters can be used to obtain elevated temperature. For lower temperatures and when using test environments containing reactive constituents in addition to hydrogen, external heating of the test cell is typically more convenient. At high temperatures when using non-reactive or hydrogen gas environments, an internal heater can be used to heat only the test specimen and the gaseous environment in the vicinity of the test specimen to limit power requirements and problems with high temperature sealing and pressure containment.

6.2.9 *Grips*—Grips shall provide for efficient and accurate transfer of load from the pull rods to the test specimen. Grips should be designed to minimize compliance in the loading system under the anticipated loads to pull the test specimen.

6.2.10 *Loading Fixture*—A fixture is used to react the load used to pull the specimen. An internal fixture is shown schematically in Fig. 1.

6.2.11 *Testing Machines*—Tension testing machines used for conducting tests according to this test method shall conform to the requirements of Practices E 4. The loads used in tests shall be within the calibrated load ranges of the testing machines in accordance with Practices E 4.

## 7. Reagents

7.1 *Purity of Reagents*—Reagent grade chemicals and ultra low oxygen gases ( $<1 \text{ ppm}$ ) shall be used in all tests unless the test environment is derived from a field or plant environment. If the test is to be conducted for aerospace propulsion applications, the environment shall consist of hydrogen gas per MIL-P-27201B.

7.2 If water is to be added to any test environment, distilled or deionized water conforming to Specification D 1193 Type IV shall be used.

## 8. Test Environment

8.1 Test environments can consist of either field or plant samples or be prepared in the laboratory from chemicals and gases as indicated in Section 7.

8.2 When testing in hydrogen containing environments, susceptibility to hydrogen embrittlement typically increases with decreasing oxygen content of the test environment. Therefore, strict procedures for deaeration shall be followed and periodically qualified for oxygen content as discussed in Sections 9 and 11.

8.3 For purposes of standardization, suggested standardized pressures for hydrogen gas testing shall be 7 MPa, 35 MPa, and 69 MPa. However, for materials evaluation for specific applications, the test pressure should be equal to or greater than that which represents the service conditions.



## 9. Sampling

9.1 The procedure for sampling mill products is typically covered in product or other specifications and is outside the scope of this document.

9.2 Sampling of the test environment is recommended to confirm that the test environment is in conformance with this test method and attains the intended test conditions. Such sampling shall be conducted immediately prior to and after testing. The frequency of environmental sampling shall be as required to cover applicable product, purchase or in-house testing specifications, or both. As a minimum requirement to be in compliance with this test method, however, sampling of the test environment shall be conducted at the start of testing and again when any element of the test procedure or test system has been changed or modified.

## 10. Test Specimens

10.1 Tension specimens shall be used for evaluation of hydrogen embrittlement. These specimens shall conform to the dimensions and guidelines provided in Test Methods E 8. However, in some cases, the material size, configuration and form or the confines of various test cells may limit the actual dimensions of the test specimen. In such cases, the specimen geometry and dimensions shall be fully described. Take care to only compare the results obtained from similar specimens.

10.2 For purposes of standardizing the evaluation of materials according to this test method, two standard test specimens shall be used: standard smooth tension specimen, and standard notched tensile specimen. The dimensions of these specimens are given in Fig. 3a and Fig. 3 b.

10.3 Specimens shall be machined to have a minimal amount of cold work on the gage or notch surfaces. Total metal removed in the last two passes shall be limited to a total of 0.05 mm and have a surface finish of  $0.25\ \mu\text{m}$  ( $10\ \mu\text{in.}$ ) or better. The method of final machining of the gage section should be by grinding (not turning) to avoid localized grooves and cold worked areas.

## 11. Standardization

11.1 To provide an indication when some inadvertent deviation from the correct test conditions occurs, it is necessary to test a control specimen of a material of known susceptibility to hydrogen embrittlement using the procedures given herein. This control material should exhibit an easily reproducible degree of embrittlement.

11.2 The control materials for tests conducted in a hydrogen containing environment shall be as given below:

11.2.1 *Low Resistance*—Low Alloy Steel: UNS G43400 (austenitize at  $900^\circ\text{C}$  for 1 h plus water quench and temper at  $454^\circ\text{C}$  for 2 h).

11.2.2 *Intermediate Resistance*—Nickel Base Alloy: UNS N07718 (solution annealed at  $954^\circ\text{C}$  for 1 h plus air cool; age at  $718^\circ\text{C}$  for 8 h plus furnace cool to  $620^\circ\text{C}$  hold for 8 h plus air cool).

11.2.3 *High Resistance*—Stainless Steels: A 286—AMS 5737 (solution annealed at  $893^\circ\text{C}$  for 1 h plus water quench and aged at  $721^\circ\text{C}$  for 16 h plus air cool).

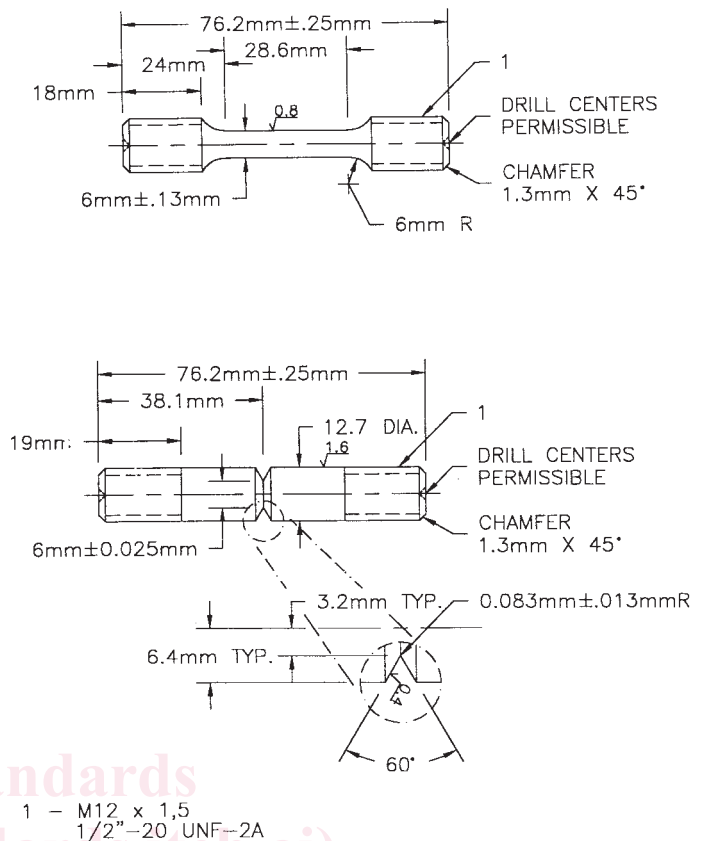

FIG. 3 Standard Tension Specimens (a) Smooth and (b) Notched

## 12. Test Procedure

12.1 Follow the basic guidelines for high pressure/high temperature corrosion testing in Guide G 111 where applicable.

12.2 Measure the initial specimen dimensions. For smooth tensile specimens, the dimensions measured are gage length and diameter. For notched specimens, the dimensions are gage and notch diameter.

12.3 Degrease and clean the specimen. Once cleaned the specimen shall not be handled with bare hands.

12.4 Mount the specimen in the test cell using suitable grips which are attached to the pull rods. Take care to prevent misalignment and non-axial loading. See Test Methods E 8 for more information. Upon initial set-up of the test cell, an alignment verification using an instrumented dummy specimen is recommended.

12.5 After sealing the test cell, remove air from the test vessel and associated system, using alternate vacuum/inert gas (that is, argon or helium) purges which reduce the oxygen level in the test cell to the desired level. The procedure for this may vary slightly depending on the specific test system used, but it should typically involve evacuation of the test cell followed by back-filling with inert gas. For testing in hydrogen containing environments, it is recommended that at least three vacuum/inert gas cycles be used. The procedure used in deaeration shall be verified by gas analysis and re-verified following any change in the pressure containing portion of the test system or deaeration procedure.

12.6 To ensure the pressure integrity of the system prior to testing, the test cell shall be pressure tested with inert gas to at