



Designation: D4796 – 17

# Standard Test Method for Bond Strength of Thermoplastic Pavement Marking Materials<sup>1</sup>

This standard is issued under the fixed designation D4796; the number immediately following the designation indicates the year of original adoption or, in the case of revision, the year of last revision. A number in parentheses indicates the year of last reapproval. A superscript epsilon ( $\epsilon$ ) indicates an editorial change since the last revision or reapproval.

## 1. Scope

1.1 This test method provides an instrumental means for the determination of thermoplastic pavement marking material bond strengths using cement bricks and loading fixtures.

1.2 The values stated in inch-pound units are to be regarded as standard. The values given in parentheses are mathematical conversions to SI units that are provided for information only and are not considered standard.

1.3 *This standard does not purport to address all of the safety concerns, if any, associated with its use. It is the responsibility of the user of this standard to establish appropriate safety, health and environmental practices and determine the applicability of regulatory limitations prior to use.*

1.4 *This international standard was developed in accordance with internationally recognized principles on standardization established in the Decision on Principles for the Development of International Standards, Guides and Recommendations issued by the World Trade Organization Technical Barriers to Trade (TBT) Committee.*

## 2. Referenced Documents

2.1 *ASTM Standards:*<sup>2</sup>

**C109/C109M Test Method for Compressive Strength of Hydraulic Cement Mortars (Using 2-in. or [50-mm] Cube Specimens)**

**D16 Terminology for Paint, Related Coatings, Materials, and Applications**

**D4541 Test Method for Pull-Off Strength of Coatings Using Portable Adhesion Testers**

**D5179 Test Method for Measuring Adhesion of Organic Coatings in the Laboratory by Direct Tensile Method**

**D7234 Test Method for Pull-Off Adhesion Strength of Coat-**

**ings on Concrete Using Portable Pull-Off Adhesion Testers**

**D7307 Practice for Sampling of Thermoplastic Traffic Marking Materials**

**D7308 Practice for Sample Preparation of Thermoplastic Pavement Marking Materials**

**E177 Practice for Use of the Terms Precision and Bias in ASTM Test Methods**

**E691 Practice for Conducting an Interlaboratory Study to Determine the Precision of a Test Method**

## 3. Terminology

3.1 The terms and definitions in Terminology **D16** apply to this method.

3.2 *Definitions of Terms Specific to This Standard:*

3.2.1 *cement brick, n*—a type of brick (a solid masonry unit, rectangular in shape) made from a mixture of cement and sand, molded under pressure and cured under steam at 200°F (93°C); used as backing brick and where there is no danger of attack from acid or alkaline conditions. These bricks are not colorized and have a compressive strength of 3000 to 5000 psi.

3.2.2 *loading fixture, n*—(also referred to as dollies, studs, or jigs) metal fixture round and flat on one end for bonding to test sample and shaped on the other end for attaching to tensile testing device. Measurements are listed in inches. (Fig. 1).

3.2.3 *thermoplastic, n*—pavement marking (same as 3.2.4).

3.2.4 *thermoplastic pavement marking, n*—a highly filled 100 % total solids highway marking system that when heated to a molten state can be extruded or sprayed onto a road surface and when cooled forms a solid durable delineator or road marking thermoplastic usually melted to 425°F (218°C).

## 4. Summary of Test Method

4.1 The thermoplastic specimen is prepared for this test by first melting a sample to its application temperature under continuous agitation. The specimen is then applied to the specified cement brick using a hot drawdown bar (Fig. 2), heated to 220 ± 5°F (104 ± 2°C), at 125 mils (3.175 mm) thickness. While the thermoplastic is still soft, three cuts are made with a 1.6 in. (40.6 mm) diameter die (Fig. 4), heated to 220 ± 5°F (104 ± 2°C), in order to separate the test area from the rest of the drawdown. The die may be heated while

<sup>1</sup> This test method is under the jurisdiction of ASTM Committee **D01** on Paint and Related Coatings, Materials, and Applications and is the direct responsibility of Subcommittee **D01.44** on Traffic Coatings.

Current edition approved July 1, 2017. Published August 2017. Originally approved in 1988. Last previous edition approved in 2010 as D4796 – 10. DOI: 10.1520/D4796-17.

<sup>2</sup> For referenced ASTM standards, visit the ASTM website, www.astm.org, or contact ASTM Customer Service at service@astm.org. For *Annual Book of ASTM Standards* volume information, refer to the standard's Document Summary page on the ASTM website.

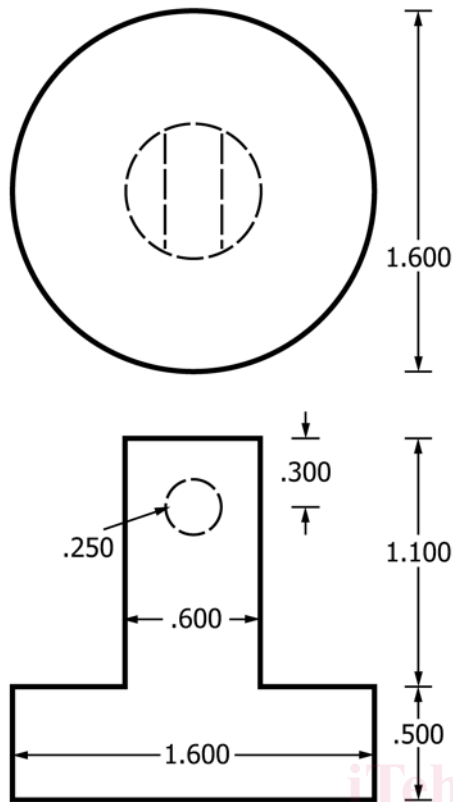

FIG. 1 Loading Fixture

## 6. Types of Separation in Bond Strength Tests

6.1 *Thermoplastic to Loading Fixture Separation*—This type of separation occurs when:

- (a) an insufficient coverage of the thermoplastic to the fixture at time of placement,
- (b) material or jig temperature is too low.

These type of separations are acceptable when the the results exceed the specified bond strength.

6.2 *Thermoplastic to Thermoplastic Separation*—This type of separation is caused by internal cohesive failure of the thermoplastic. This separation is acceptable when it exceeds the specified bond strength.

6.3 *Thermoplastic to Cement Brick Separation*—This type of separation is caused by the failure of the bond between the thermoplastic specimen and the cement brick. This separation is acceptable when it exceeds the specified bond strength.

6.4 *Cement Brick to Cement Brick*—This type of separation is caused by the internal cohesive failure of the brick. This is due, in most cases, to a bond between the thermoplastic and cement brick that exceeds the cohesive strength of the cement brick. This separation is not acceptable when the bond strength values are lower than specified.

## 7. Apparatus

7.1 *Loading Fixture (three)*, 1.6 in. (40.6 mm) diameter 2 sq in. (50.8 sq mm) area on one end and post for attaching to the tensile testing device and load cell (Fig. 1).

7.2 *Cement Bricks*, 3.75 by 2.5 by 7.75 in. (9 by 5.5 by 19 cm) in size with a compressive strength of 3000 to 5000 psi (210.9 to 351.5 kg/m<sup>2</sup>).

NOTE 1—Cement bricks can be obtained at a local block plant or Block USA. Home improvement paving bricks usually do not have enough cohesive strength. Concrete bricks conforming to Test Method C109/C109M have been used but proved more variable due to migration of a thin veneer of cement to the top of the brick making determinations erratic. The cement bricks may be obtained from local block plants. The term cement brick is common for the industry and is used in this test method extensively.

7.3 *Tensile Testing Equipment* with a minimum capacity of 200 ± 2 lbs (910 ± 1 kg) having a pull-rate capability of at least 0.275 in./min (7 mm/min).

NOTE 2—The unit should be fitted with a steel frame to hold the cement brick for testing (see Fig. 3).

7.4 *Drawdown Bar*, 2 by 1 by 4 in. (5 by 2.5 by 10 cm) in size capable of laying down a 125 mil or 0.125 in. (3.175 mm) molten thermoplastic film 2 in. (50.8 mm ) wide (Fig. 2).

7.5 *Hot Plate*, capable of maintaining 220 ± 5°F (104 ± 2°C).

7.6 *Oven*, capable of maintaining 425 ± 5°F (218 ± 2°C).

7.7 *Die Cutter*, 1.6 in. (40.6 mm) diameter (Fig. 4).

7.8 *Metal Frame* for holding concrete brick (Fig. 3).

## 8. Sampling

8.1 Samples may be obtained by following Practice D7307.

submerged in glycerin to prevent thermoplastic from sticking to the die. The test areas are allowed to cool slightly and then three 1.6 in. (40.6 mm) diameter heated loading fixtures are laid on the test areas. The samples are then allowed to cure overnight before determining the bond strength on a tensile testing device.

## 5. Significance and Use

5.1 The function of this test method is to provide numerical instrumental results indicating the cohesive and/or adhesive bond strength of thermoplastic pavement marking to a specified cement brick substrate.

5.2 The use of this test method allows the user and manufacturer to control the quality of the product and make inferences about the performance of the thermoplastic pavement marking product. Results from these tests also provide information helpful in researching and developing thermoplastic pavement marking materials.

5.3 The method has been revised to be more consistent to methodology in other ASTM bond methods for coatings in Test Methods D4541, D5179, and D7234.

5.4 Strict adherence to the procedures outlined is necessary for precision of the test method. Under no conditions should the bond strength be accepted unless there is conformance to the method.

2 inch Draw Down Bar

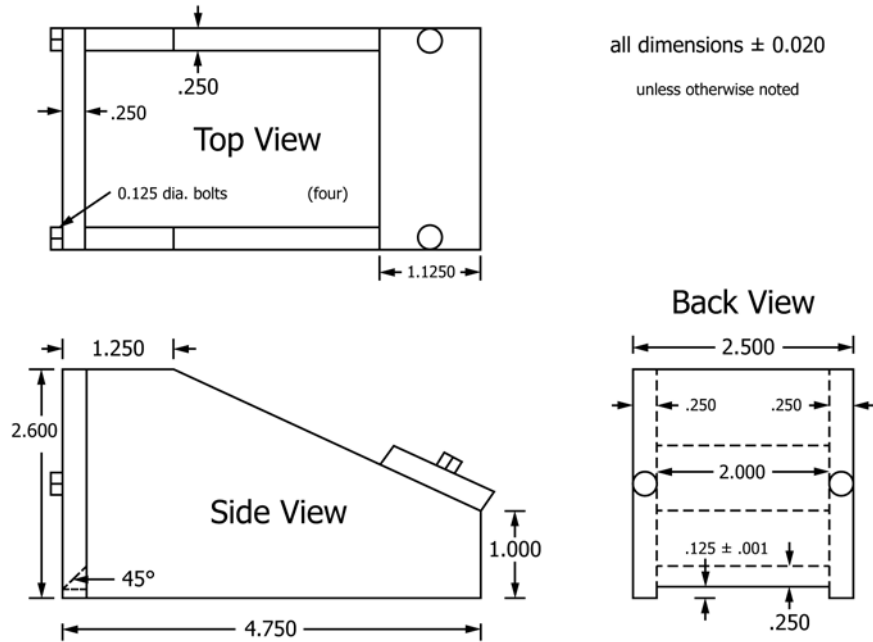

FIG. 2 Drawdown Bar (in inches)

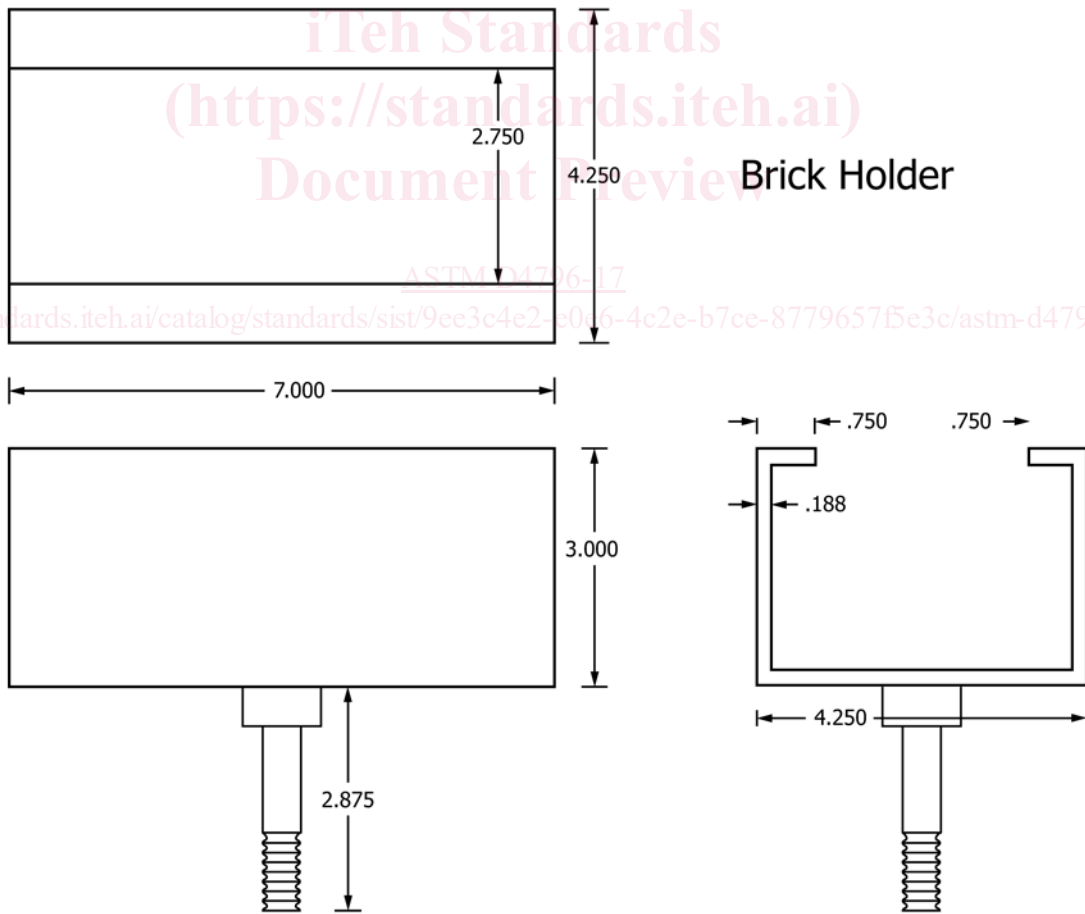

FIG. 3 Brick Holder