



Designation: D1525 – 17^ε¹

Standard Test Method for Vicat Softening Temperature of Plastics¹

This standard is issued under the fixed designation D1525; the number immediately following the designation indicates the year of original adoption or, in the case of revision, the year of last revision. A number in parentheses indicates the year of last reapproval. A superscript epsilon (ϵ) indicates an editorial change since the last revision or reapproval.

This standard has been approved for use by agencies of the U.S. Department of Defense.

^ε¹ NOTE—Editorial changes were made throughout the standard in September 2017.

1. Scope*

1.1 This test method covers determination of the temperature at which a specified needle penetration occurs when specimens are subjected to specified controlled test conditions.

1.2 This test method is not recommended for ethyl cellulose, nonrigid poly(vinyl chloride), poly(vinylidene chloride), or other materials having a wide Vicat softening range.

1.3 The values stated in SI units are to be regarded as standard. No other units are included in this standard.

1.4 Due to the potential safety and environmental hazards associated with mercury-filled thermometers, the use of alternative temperature measuring devices (such as thermocouples and RTDs) is encouraged with liquid-in-glass thermometers containing mercury, the use of alternative measuring devices, such as digital thermometers using thermocouple or RTD sensors is encouraged.

1.5 *This standard does not purport to address all of the safety concerns, if any, associated with its use. It is the responsibility of the user of this standard to establish appropriate safety, health and environmental practices and determine the applicability of regulatory limitations prior to use.*

NOTE 1—This test method is equivalent to ISO 306 in all sections with the exceptions of the allowance for creep, prior to the beginning of the test and the allowance of the fluidized powder as a heat transfer medium.

1.6 *This international standard was developed in accordance with internationally recognized principles on standardization established in the Decision on Principles for the Development of International Standards, Guides and Recommendations issued by the World Trade Organization Technical Barriers to Trade (TBT) Committee.*

¹ This test method is under the jurisdiction of ASTM Committee D20 on Plastics and is the direct responsibility of Subcommittee D20.30 on Thermal Properties (Section D20.30.07).

Current edition approved Aug. 1, 2017. Published August 2017. Originally approved in 1958. Last previous edition approved in 2009 as D1525 - 09. DOI: 10.1520/D1525-17E01.

2. Referenced Documents

2.1 ASTM Standards:²

- D618 Practice for Conditioning Plastics for Testing
- D883 Terminology Relating to Plastics
- D1898 Practice for Sampling of Plastics (Withdrawn 1998)³
- E1 Specification for ASTM Liquid-in-Glass Thermometers
- E77 Test Method for Inspection and Verification of Thermometers
- E608/E608M Specification for Mineral-Insulated, Metal-Sheathed Base Metal Thermocouples
- E691 Practice for Conducting an Interlaboratory Study to Determine the Precision of a Test Method
- E879 Specification for Thermistor Sensors for General Purpose and Laboratory Temperature Measurements
- E1137/E1137M Specification for Industrial Platinum Resistance Thermometers
- E2251 Specification for Liquid-in-Glass ASTM Thermometers with Low-Hazard Precision Liquids
- E2935 Practice for Conducting Equivalence Testing in Laboratory Applications

2.2 ISO Standards:⁴

- ISO 306 Plastics—Thermoplastic Material—Determination of Vicat Softening Temperature

3. Terminology

3.1 Definitions:

3.1.1 Definitions of plastics used in this test method are in accordance with those defined in Terminology D883, unless otherwise specified.

3.1.2 *Vicat softening temperature*—the temperature at which a flat-ended needle of 1-mm² circular cross section will penetrate a thermoplastic specimen to a depth of 1 mm under

² For referenced ASTM standards, visit the ASTM website, www.astm.org, or contact ASTM Customer Service at service@astm.org. For *Annual Book of ASTM Standards* volume information, refer to the standard's Document Summary page on the ASTM website.

³ The last approved version of this historical standard is referenced on www.astm.org.

⁴ Available from American National Standards Institute (ANSI), 25 W. 43rd St., 4th Floor, New York, NY 10036, <http://www.ansi.org>.

*A Summary of Changes section appears at the end of this standard

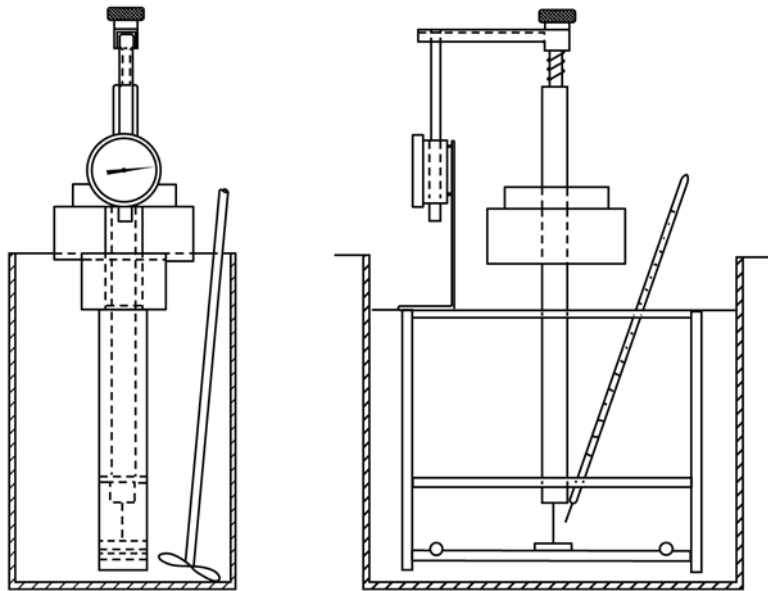

FIG. 1 Apparatus for Softening Temperature Determination (Immersion Bath)

a specified load (force) perpendicular to the test specimen using a selected uniform rate of temperature rise.

4. Summary of Test Method

4.1 A flat-ended needle loaded with a specified mass is placed in direct contact with a test specimen. The mass applied can be one of two accepted loads, as follows:

Loading 1 – 10 ± 0.2 N

Loading 2 – 50 ± 1.0 N

The specimen and needle are heated at either of two permissible rates, as follows:

Rate A – $50 \pm 5^\circ\text{C}/\text{h}$

Rate B – $120 \pm 10^\circ\text{C}/\text{h}$

The temperature at which the needle has penetrated to a depth of 1 ± 0.01 mm is recorded as the Vicat softening temperature.

5. Significance and Use

5.1 Data obtained by this test method is used to compare the heat-softening qualities of thermoplastic materials.

5.2 This test method is useful in the areas of quality control, development, and characterization of plastic materials.

6. Apparatus

6.1 The instrument shall have a heating system consisting of a heated bath (see Fig. 1) or a contact heating system (see Fig. 2):

The equipment shall be constructed essentially as shown in Fig. 2 and shall consist of the following:

6.1.1 *Immersion Bath*—An immersion bath containing the heat-transfer medium shall be equipped with an agitation system, temperature-measuring device, and heater. The heater shall have automatic control of the selected bath temperature-rise rate (see 4.1). The bath shall be constructed to allow the

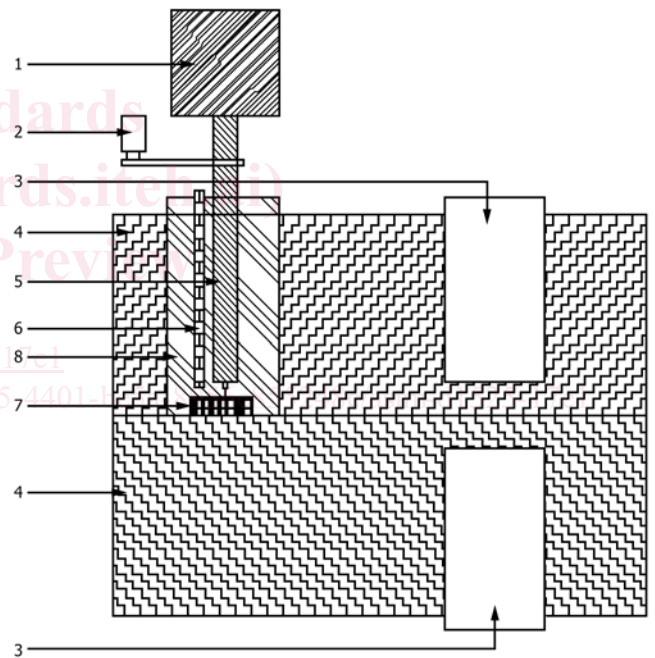

Key

- 1 Weight
- 2 Displacement-measurement device
- 3 Heater(s) (Note that multiple heaters are placed symmetrically throughout the instrument and not just in the one location shown.)
- 4 Heating block (contains lower contact plate)
- 5 Load rod with needle
- 6 Temperature-measuring device
- 7 Test specimen
- 8 Contact plate

FIG. 2 Apparatus for Softening Temperature Determination (Direct Contact)

specimens to be submerged at least 35 mm below the surface of the heat-transfer medium.

6.1.1.1 *Heat-Transfer Medium*—Shall be a liquid or fluidized powder.⁵ Several liquids, such as silicone oils, glycerine, ethylene glycol, and mineral oil have been used successfully for various plastics.⁶ The medium used shall be free from contaminants and shall have no short-time effect at elevated temperatures on the material being tested, liquid mediums shall be of low viscosity at room temperature.

NOTE 2—The results of the test can depend on the thermal diffusivity of the heat-transfer medium.

6.1.2 *Contact Heating Unit*—Shall consist of heater and heater blocks which, through conductive heating, raises the temperature of the specimen at the required controlled rate until the VICAT Softening Temperature is reached.

NOTE 3—It is desirable to have a method of cooling or heating the bath in order to reduce the time required to change the temperature of the bath between tests more quickly. This may be accomplished by using a cooling coil installed in the bath or an external heat-transfer system. If the temperature rise rate is adversely affected by the presence of residual coolant in the cooling coils, the coolant should be purged prior to beginning the test.

6.1.3 *Specimen Support*—A suitable stand or support for the specimen to be placed in the bath or be part of the contact heating structure. The vertical members that attach the specimen support to the upper plate shall be made of a material having the same coefficient of expansion as that used for the rod through which the load is applied in order that the penetration-measuring device reading caused by differential expansion over the intended temperature range does not exceed 0.02 mm when the specimen is replaced by a piece of heat-resistant material.⁷

6.1.4 *Penetration-Measuring Device*—The device used for measuring the penetration of the specimen shall be capable of measuring a penetration depth of at least 1 ± 0.01 mm. The measuring device shall be an analog or digital dial gauge or similar device, including an electronic-displacement sensing apparatus.

6.1.5 *Masses*—A set of masses of suitable sizes shall be supplied so that the net force on the needle point shall be equal to 10 ± 0.2 N (Loading 1) or 50 ± 1.0 N (Loading 2) when the apparatus is assembled. The net force shall consist of the weight of the needle rod assembly, the force attributed to action of the penetration-measuring device, and the extra weight that is required to balance the system. The required mass is calculated as follows:

$$\text{Required mass, } m_w = (F - F_s)/9.80665 - m_r$$

where:

- F = total force to be applied to the specimen, N,
- F_s = force exerted by any penetration-measuring device, N (this is a positive value if the thrust of the spring is towards the specimen (downward), a negative value if the thrust of the spring is opposing the descent of the rod, or zero if no such device is involved),

⁵ Aluminum Oxide has been found satisfactory and safe for short-term heat cycles up to 500°C.

⁶ Silicone oils having a room temperature viscosity of 100 cP have been found satisfactory and safe for short-term heat cycles up to 260°C.

⁷ Borosilicate glass or Quartz has been found satisfactory for this purpose.

- m_r = mass of the needle rod assembly, kg, and
- m_w = extra mass applied to attain the desired force, kg.

Verification of the load shall be made on new equipment and after replacing penetration-measuring devices, or at any time to ensure that the equipment is in calibration. The calibration procedure for dial-gauge-type penetration-measuring devices is described in **Appendix X1** and **Appendix X2**. The methods for determination of the thrust contributed by dial-gauge-type penetration-measuring devices are also given in **Appendix X1** and **Appendix X2**.

6.1.6 *Temperature-Measuring Device*, consisting of a sensor (for example, thermocouple, resistance thermometer (RTD), thermistor probe (**E879**), or platinum resistance thermometer (PRT)).

6.1.6.1 *Digital Thermometer*—A digital indicating device incorporating a sensor (that is, thermocouple probe, thermistor probe, or platinum resistance thermometer (PRT)) with associated conditioning, conversion, and readout instrumentation adequate to cover the range being tested. The sensor and related electronics shall be accurate to at least $\pm 0.5^\circ\text{C}$. Thermocouples shall comply with the requirements of Specification **E608/E608M**. Resistance thermometers shall comply with the requirements of Specification **E1137/E1137M**.

6.1.6.2 *Liquid-in-Glass Thermometer*—Older systems still in existence use a thermometer for temperature measurement at each individual test station. The thermometer shall be one of the following, or its equivalent, as prescribed in Specification **E1**: Thermometer 1C or 2C, having ranges from -20 to 150°C or -5 to 300°C , respectively, whichever temperature range is most suitable. Liquid-in-glass thermometers (refer to Specification **E2251**) shall be calibrated for the depth of immersion in accordance with Test Method **E77**.

NOTE 4—WARNING—Mercury has been designated by EPA and many state agencies as a hazardous material that can cause central nervous system, kidney and liver damage. Mercury, or its vapor, may be hazardous to health and corrosive to materials. Caution should be taken when handling mercury and mercury containing products. See the applicable product Material Safety Data Sheet (MSDS) for details and EPA's website- <http://www.epa.gov/mercury/faq.htm> - for additional information. Users should be aware that selling mercury and/or mercury containing products into your state may be prohibited by state law.

6.1.7 *Needle*—A flat-tipped, hardened steel needle with a cross-sectional area of 1.000 ± 0.015 mm² (diameter of 1.120 to 1.137 mm) shall be used. The tip shall be free of burrs and be perpendicular to the axis of the rod. The needle shall protrude at least 2 mm from the end of the rod.

7. Sampling

7.1 Unless otherwise agreed upon between the seller and the purchaser, sample in accordance with the sections on General Sampling Procedures and Specific Sampling Procedures of Practice **D1898**. Sampling based on engineering principles, prior to packaging, shall be considered an acceptable alternative.

8. Test Specimen

8.1 Use at least two specimens to test each sample. The specimen shall be flat, between 3 and 6.5 mm thick, and at least 10 by 10 mm in area or 10 mm in diameter. If an individual

layer of the specimen is less than 3 mm it is permissible to stack not more than three (3) layers to achieve the minimum thickness. The specimens shall be cut from sheet or molded material. The type of mold and the molding process used to produce test specimens will affect the results obtained in the test. Molding conditions shall be in accordance with the standard for the material being tested or be agreed upon between the cooperating laboratories.

NOTE 5—Discrepancies in test results due to variations in molding conditions often are minimized by annealing the test specimens before the test. Since different materials require different annealing conditions, annealing procedures shall be employed only if required by the material standard or if agreed upon between the cooperating laboratories.

9. Conditioning

9.1 If conditioning of the specimens is required, the test specimens shall be conditioned at $23 \pm 2^\circ\text{C}$ and at $50 \pm 10\%$ relative humidity for not less than 40 h in accordance with Procedure A of Practice D618, unless otherwise specified by agreement or the relevant ASTM material specification. In cases of disagreement, the tolerances shall be $\pm 1^\circ\text{C}$ and $\pm 5\%$ relative humidity.

NOTE 6—Conditioning periods less than the 40 h, as specified by Practice D618, may be used when it is shown that the Vicat softening temperature is not affected by the shorter conditioning time. Longer conditioning times may be required for some materials that take longer to reach temperature and humidity equilibrium. Refer to the applicable ASTM standards for those materials.

10. Procedure

10.1 Prepare the instrument so that the temperature of the heat-transfer medium or contact plates is between 20 and 23°C at the start of the test unless previous tests have shown that for a particular material under test no error is introduced by starting at a higher temperature. The immersion bath system shall be well agitated.

10.1.1 If it is not possible to reduce the temperature of the heat-transfer medium to $20\text{--}23^\circ\text{C}$, it is permissible to start with the bath temperature at 30°C . The selection of the starting temperature shall be agreed upon between the cooperating laboratories.

10.2 Place the specimen, which is at room temperature, on the specimen support so that it is approximately centered under the needle. Ensure that the needle is at least 3 mm from the edge of the specimen. Gently lower the needle rod, without the extra mass, so that the needle rests on the surface of the specimen and holds it in position.

10.3 Position the temperature measuring device so that the sensing end is located within 10 mm from where the load is applied to the surface of the specimen. Ensure that the sensing end does not touch the specimen.

10.4 Lower the assembly into the bath or close the contact plates, taking care not to jar it in any way that would damage or dislodge the specimen.

10.5 Apply the extra mass required to increase the load on the specimen to $10 \pm 0.2\text{ N}$ (Loading 1) or $50 \pm 1.0\text{ N}$ (Loading 2). After a 5-min waiting period, set the penetration indicator to zero.

10.6 Start the temperature rise. The rate of temperature increase shall be either $50 \pm 5^\circ\text{C/h}$ (Rate A) or $120 \pm 10^\circ\text{C/h}$ (Rate B) and shall be uniform throughout the test. The Rate A heating requirement shall be considered to be met if over every 12-min interval during the test, the temperature of the bath or contact plates rises $10 \pm 1^\circ\text{C}$ at each specimen location. The Rate B heating requirement shall be considered to be met if over every 6-min interval during the test, the temperature of the bath or contact plates rises $12 \pm 1^\circ\text{C}$ at each specimen location. The selection of the rate of rise shall be agreed upon between cooperating laboratories. See Annex A1 for calibration of single temperature probe units.

10.7 Record the temperature of the bath or contact plates when the needle has penetrated $1 \pm 0.01\text{ mm}$ into the test specimen. Make sure that an accurate reading of the temperature is made since the rate of penetration of the specimen will be increasing rapidly at this point.

10.8 Express the Vicat softening temperature as the arithmetic mean of the temperature of penetration of all specimens tested. If the range of penetration temperatures for the individual test specimens exceeds 2°C , record the individual results and repeat the test, using at least two new specimens.

NOTE 7—If a permanent record is desired, either read and record the penetration for each 5°C rise in temperature until the penetration reaches 0.4 mm, and at 2°C intervals thereafter, or attach a displacement transducer, having the same resolution as the gauge, to each rod and continuously record the rate of penetration by means of a multichannel recorder or similar data-acquisition device.

NOTE 8—Some commercially available instruments record the time at which the penetration reaches a set depth. If this type of instrument is used, make a time-temperature calibration before the specimens are tested. This calibration compensates for slight variations in the heating rate. (Even though the variations may be within the specifications set forth in 10.6, the compounded error over the range of the test can produce a substantial error in the Vicat softening temperature.)

11. Report

11.1 Report the following information:

11.1.1 Reference to this test method,

11.1.2 Complete identification of the material tested,

11.1.3 Method of preparing test specimens, including conditioning and annealing methods used,

11.1.4 Initial starting temperature,

11.1.5 Rate of temperature rise, Rate A (50°C/h) or Rate B (120°C/h),

11.1.6 Total load applied to the specimen, Loading 1 ($10 \pm 0.2\text{ N}$) or Loading 2 ($50 \pm 1.0\text{ N}$),

11.1.7 Thickness of the specimen and the number of layers of the material that were used,

11.1.8 Type of instrument used: Immersion bath and heat-transfer medium used or contact plates,

TABLE 1 Vicat Softening Temperature Using Loading 1 and Rate B, Values Expressed in Units of °C

Material	Average	S_r^A	S_R^B	r^C	R^D	Number of Participating Laboratories
Ethylene vinyl acetate	72.4	1.44	2.29	4.03	6.40	10
Polystyrene	97.3	0.68	2.36	1.91	6.62	10
High-density polyethylene	127.9	1.04	2.73	2.90	7.63	10
Polypropylene	152.5	1.13	2.83	3.16	7.91	10
Nylon 66	251.2	0.70	5.06	1.96	14.16	7

^A S_r = within-laboratory standard deviation of the average.

^B S_R = between-laboratories standard deviation of the average.

^C r = within-laboratory repeatability limit = 2.8 S_r .

^D R = between-laboratories reproducibility limit + 2.8 S_R .

11.1.9 Vicat softening temperature, expressed as the arithmetic mean of the Vicat softening temperatures of the individual specimens, and

11.1.10 Any observations relating to the test.

12. Precision and Bias⁸

12.1 *Precision*—Tables 1 and 2 have been developed in accordance with Practice E691. Table 1, for the case using Loading 1 (10 ± 0.2 N) and Heating Rate B (120 ± 10°C/h) is based on round-robin tests conducted in 1982 involving five materials and differing numbers of laboratories as noted in the table. Each laboratory obtained three test results for each material. Table 2, for the case using Loading 2 (50.0 ± 1.0 N) and Heating Rate A (50 ± 5°C/h) is based on round-robin tests conducted in 1994 involving 8 materials and six laboratories. Each laboratory obtained two test results for each material. In both cases, for each material, all of the individual specimens from all material samples were prepared by one source. Each test result was the average of two individual determinations. (**Warning**—The following explanations of r and R (see 12.1.1 – 12.1.1.3) are intended only to present a meaningful way of considering the approximate precision of this test method. The data given in Tables 1 and 2 shall not be applied rigorously to the acceptance or rejection of material, as those data are specific to the round-robin test and are not representative of other lots, conditions, materials, or laboratories. Users of this

test method need to apply the principles outlined in Practice E691 to generate data specific to their laboratory and materials, or between specific laboratories. The principles of 12.1.1 – 12.1.1.3 would then be valid for such data.)

12.1.1 *Concept of r and R* —If S_r and S_R have been calculated from a large enough body of data, and for test results that were averages from testing two specimens, the following applies:

12.1.1.1 *Repeatability, r* —The value that the absolute difference between two individual test results under repeatability conditions are expected to occur with a probability of approximately 0.95 (95 %).

12.1.1.2 *Reproducibility, R* —The value that the absolute difference between two test results obtained under reproducibility conditions are expected to occur with a probability of approximately 0.95 (95 %).

12.1.1.3 Conducting equivalence testing on numerical data from two sources shall be conducted in accordance with Practice E2935 or any known method for judging the equivalence of two means.

NOTE 9—Example a t-test.

12.2 *Bias*—There are no recognized standards by which to estimate the bias of this test method.

NOTE 10—Reinforced materials have been shown to sometimes break at the point of penetration at temperatures above 24°C, which can affect the repeatability of the test results.

13. Keywords

13.1 plastics; thermoplastics; Vicat softening temperature

⁸ Supporting data have been filed at ASTM International Headquarters and may be obtained by requesting Research Report RR: D20-1194.

TABLE 2 Vicat Softening Temperature Using Loading 2 and Rate A, Values Expressed in Units of °C

Material	Average	S_r^A	S_R^B	r^C	R^D
Polypropylene (PP0343)	56.2	1.07	1.86	2.99	5.22
Polypropylene (PP0114)	92.5	1.47	4.08	4.12	11.44
Impact Modified Acrylic (PMMA0230V1)	94.1	0.32	1.96	0.91	5.48
ABS	94.4	0.62	1.61	1.74	4.52
High Heat ABS (ABS0135)	100.8	0.34	1.53	0.95	4.29
Unmodified Acrylic (PMMA0141V3)	105.1	0.44	1.48	1.23	4.15
Polycarbonate (PC0136)	143.6	0.19	1.24	0.53	3.48
Polycarbonate (PC0123)	143.8	0.38	1.03	1.05	2.89

^A S_r = within-laboratory standard deviation for the indicated material. It is obtained by pooling the within-laboratory standard deviations of the test results from all of the participating laboratories:

$$S_r = [((S_1)^2 \dots + (S_n)^2)/n]^{1/2}$$

^B S_R = between-laboratories reproducibility, expressed as standard deviation: $S_R = [S_r^2 + S_L^2]^{1/2}$ where S_L = standard deviation of laboratory means.

^C r = within-laboratory critical interval between two test results = $2.8 \times S_r$.

^D R = between-laboratories critical interval between two test results = $2.8 \times S_R$.

TABLE 3 VICAT Softening Temperature Using a Direct Contact Instrument (Results are repeatability data on a single instrument.)

Material	Thickness	Method	1	2	3	4	5	6	min	max	Average	st. dev.
(PC)	4.0 mm	B2	141.1	140.2	141.3	140.5	141.7	140.7	140.2	141.7	140.9	0.6
	4.0 mm	B2	141.2	140.1	141.3	140.5	142.0	140.6	140.1	142.0	141.0	0.7
	4.0 mm	B2	141.2	140.5	141.4	140.7	141.9	140.3	140.3	141.9	141.0	0.6
	4.0 mm	B2	141.3	140.5	141.4	140.6	141.8	140.8	140.5	141.8	141.1	0.5
	4.0 mm	B2	141.5	140.5	141.6	140.8	140.9	140.9	140.5	141.6	141.1	0.5
		min	141.1	140.1	141.3	140.5	141.7	140.3	140.1	141.7	140.8	0.6
		max	141.3	140.5	141.6	140.8	142.0	140.9	140.5	142.0	141.2	0.6
		average	141.2	140.4	141.4	140.6	141.9	140.7	140.4	141.9	141.0	0.6
		st. dev.	0.1	0.2	0.1	0.1	0.1	0.2	0.1	0.2	0.1	0.1
	4.0 mm	A2	140.3	139.9	140.3	140.2	140.6	140.0	139.9	140.6	140.2	0.2
	4.0 mm	A2	140.5	139.8	140.4	140.1	140.8	140.0	139.8	140.8	140.3	0.4
		min	140.3	139.8	140.3	140.0	140.6	140.0	139.8	140.6	140.2	0.3
	max	140.5	140.2	140.4	140.2	140.8	140.0	140.0	140.8	140.4	0.3	
	average	140.4	140.0	140.4	140.1	140.7	140.0	140.0	140.7	140.3	0.3	
	st. dev.	0.1	0.2	0.1	0.1	0.1	0.0	0.0	0.2	0.1	0.1	
(PS)	4.0 mm	A2	88.7	88.4	88.5	88.3	88.9	88.0	88.0	88.9	88.5	0.3
	4.0 mm	A2	88.5	88.3	88.5	88.1	88.6	88.0	88.0	88.6	88.3	0.2
	4.0 mm	A2	88.5	88.4	88.5	88.1	88.7	87.8	87.8	88.7	88.3	0.3
		min	88.5	88.3	88.5	88.1	88.6	87.8	87.8	88.6	88.3	0.3
		max	88.7	88.4	88.5	88.3	88.9	88.0	88.0	88.9	88.5	0.3
		average	88.6	88.4	88.5	88.2	88.7	87.9	87.9	88.7	88.4	0.3
		st. dev.	0.1	0.1	0.0	0.1	0.2	0.1	0.0	0.2	0.1	0.1
(HDPE)	3.1 mm	A1		123.3	125.5	123.2	124.5	123.4	123.2	125.5	124.0	1.0
	3.1 mm	A1	124.0	124.0	125.8	124.4	125.2	123.8	123.8	125.8	124.5	0.8
	3.1 mm	A1		123.2	125.4	124.0	124.9	124.1	123.2	125.4	124.3	0.9
	3.1 mm	A1	123.5	122.9	125.3	124.0	124.8	123.5	122.9	125.3	124.0	0.9
	3.1 mm	A1	123.5	123.1	124.8	124.0	125.0	123.7	123.1	125.0	124.0	0.7
		min	123.5	122.9	124.8	123.2	124.5	123.4	122.9	124.8	123.7	0.8
		max	124.0	124.0	125.8	124.4	125.2	124.1	124.0	125.8	124.6	0.7
		average	123.7	123.3	125.4	123.9	124.9	123.7	123.3	125.4	124.1	0.8
		st. dev.	0.3	0.4	0.4	0.4	0.3	0.3	0.3	0.4	0.3	0.1