



Designation: **D1895 – 96 (Reapproved 2010)^{ε1} D1895 – 17**

Standard Test Methods for Apparent Density, Bulk Factor, and Pourability of Plastic Materials¹

This standard is issued under the fixed designation D1895; the number immediately following the designation indicates the year of original adoption or, in the case of revision, the year of last revision. A number in parentheses indicates the year of last reapproval. A superscript epsilon (ϵ) indicates an editorial change since the last revision or reapproval.

This standard has been approved for use by agencies of the U.S. Department of Defense.

^{ε1} NOTE—Added research report information to Section 1.4 editorially in September 2010.

1. Scope—Scope*

1.1 ~~These~~ These test methods cover the measurement of apparent density, bulk factor, and where applicable, the pourability of plastic materials such as molding powders. Different procedures are given for application to the various forms of these materials that are commonly encountered, from fine powders and granules to large flakes and cut fibers.

1.2 The values stated in SI units are to be regarded as the standard. The values in parentheses are for information only.

1.3 *This standard does not purport to address all of the safety concerns, if any, associated with its use. It is the responsibility of the user of this standard to establish appropriate safety, health and ~~health~~ environmental practices and determine the applicability of regulatory limitations prior to use.*

NOTE 1—Test Method A is equivalent to ISO Method R 60 as described in the appendix. Test Method C is identical with ISO Method R 61.

1.4 *This international standard was developed in accordance with internationally recognized principles on standardization established in the Decision on Principles for the Development of International Standards, Guides and Recommendations issued by the World Trade Organization Technical Barriers to Trade (TBT) Committee.*

2. Referenced Documents

2.1 *ASTM Standards:*²

D792 Test Methods for Density and Specific Gravity (Relative Density) of Plastics by Displacement

D883 Terminology Relating to Plastics

D1505 Test Method for Density of Plastics by the Density-Gradient Technique

2.2 *ISO Standards:*³

R60 Determination of Apparent Density of Molding Materials that Can be Poured from a Specified Funnel

R61 Determination of Apparent Density of Molding Material that Cannot be Poured from a Specified Funnel

3. Terminology

3.1 *Definitions:*

3.1.1 *apparent density*—the weight per unit volume of a material, including voids inherent in the material as tested.

3.1.1.1 The term *bulk density* is commonly used for materials such as molding powder.

3.1.2 *bulk factor*—the ratio of the volume of any given quantity of the loose plastic material to the volume of the same quantity of the material after molding or forming. The bulk factor is also equal to the ratio of the density after molding or forming to the apparent density of the material as received.

3.1.3 *pourability*—a measure of the time required for a standard quantity of material to flow through a funnel of specified dimensions.

¹ These test methods are under the jurisdiction of ASTM Committee **D20** on Plastics and are the direct responsibility of Subcommittee **D20.70** on Analytical Methods. Current edition approved Jan. 1, 2010/Sept. 1, 2017. Published January 2010/September 2017. Originally approved in 1961. Last previous edition approved in 2003/2010 as D1895 – 96(2003)/(2010)^{ε1}. DOI: 10.1520/D1895-17.

This edition includes the addition of an extensive ISO equivalency statement and keywords section. DOI: 10.1520/D1895-96R10E01.

² For referenced ASTM standards, visit the ASTM website, www.astm.org, or contact ASTM Customer Service at service@astm.org. For *Annual Book of ASTM Standards* volume information, refer to the standard's Document Summary page on the ASTM website.

³ Available from American National Standards Institute (ANSI), 25 W. 43rd St., 4th Floor, New York, NY 10036, <http://www.ansi.org>.

*A Summary of Changes section appears at the end of this standard

4. Significance and Use

- 4.1 These test methods provide useful indexes of performance of plastic materials such as powders and granules with respect to their handling in packaging and fabrication.
- 4.2 Apparent density is a measure of the fluffiness of a material.
- 4.3 Bulk factor is a measure of volume change that may be expected in fabrication.
- 4.4 Pourability characterizes the handling properties of a finely divided plastic material. It is a measure of the readiness with which such materials will flow through hoppers and feed tubes and deliver uniform weights of material.

APPARENT DENSITY
Test Method A—Method A

5. Scope

5.1 Test Method A (see Note 1) covers the measurement of the apparent density of the fine granules and powders that can be poured readily through a small funnel.

5. Scope

5.1 Test Method A (see Note 1) covers the measurement of the apparent density of the fine granules and powders that can be poured readily through a small funnel.

6. Apparatus

6.1 *Measuring Cup*—A cylindrical cup of $100 \pm 0.5\text{-cm}^3$ capacity, having a diameter equal to half the height, for example, 39.9-mm (1.572-in.) inside diameter by 79.8-mm (3.144-in.) inside height, as shown in Fig. 1.

NOTE 2—Example, 39.9-mm (1.572-in.) inside diameter by 79.8-mm (3.144-in.) inside height.

6.2 *Funnel*, having a 9.5-mm diameter opening at the bottom, and mounted at a height 38 mm above the measuring cup, as shown in Fig. 1.

7. Procedure

7.1 With the apparatus assembled as shown in Fig. 1, close the small end of the funnel with the hand or with a suitable flat strip and pour a $115 \pm 5\text{-cm}^3$ sample into the funnel. Open the bottom of the funnel quickly and allow the material to flow freely into the cup. If caking occurs in the funnel, the material may be loosened with use a small glass rod.

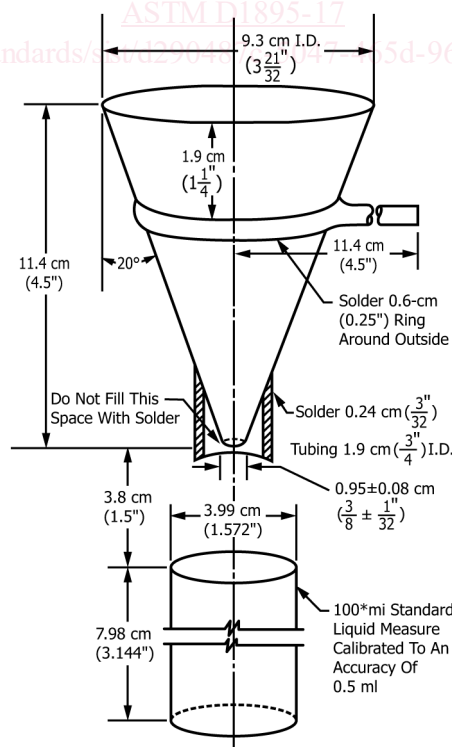

FIG. 1 Apparatus for Apparent Density Test, Method A

7.2 After all the material has passed through the funnel, immediately scrape off the excess on the top of the cup with a straightedge without shaking the cup. Weigh the material in the cup to the nearest 0.1 g. Calculate the weight in grams of 1 cm³ of the material.

NOTE 3—To convert grams per cubic centimetre to ounces per cubic inch, multiply by 0.578. To convert to grams per cubic inch multiply by 16.39. To convert grams per cubic centimetre to pounds per cubic foot, multiply by 62.43.

NOTE 4—Apparent density figures are not comparable except on materials having the same specific gravity after molding or forming.

7.3 ~~Very~~ For very fine materials that will bridge and not flow through the funnel ~~may be poured~~ pour lightly from a paper held approximately 38 mm (1.5 in.) above the opening of the measuring cup.

NOTE 5—Finely divided powders may collect electrostatic charges which, if present at the time of measurement, may result in variable apparent density values. The use of an anti-static agent mixed with the powders at a 0.2 weight percent may eliminate electrostatic charges.

Test Method B

8. Scope

8.1 Test Method B covers the measurement of the apparent density of coarse, granular materials, including dice and pellets, that either cannot be poured or that pour with difficulty through the funnel described in Test Method A.

8. Scope

8.1 Test Method B covers the measurement of the apparent density of coarse, granular materials, including dice and pellets, that either cannot be poured or that pour with difficulty through the funnel described in Test Method A.

9. Apparatus

9.1 Measuring Cup—A cylindrical cup of 400-cm³ capacity, as shown in Fig. 2.

9.2 Funnel, having a 25.4-mm (1-in.) diameter opening at the bottom, and mounted at a height 38 mm (1.5 in.) above the measuring cup, as shown in Fig. 2.

NOTE 6—Finely divided powders may collect electrostatic charges which, if present at the time of measurement, may result in variable apparent density values. Carbon black is a material that may be premixed with the sample at concentrations of 0.05 to 0.10 to reduce this variability (Superba Black with a bulk density of about 8 lb/ft³ may eliminate electrostatic charges.³ has been found satisfactory for some materials).

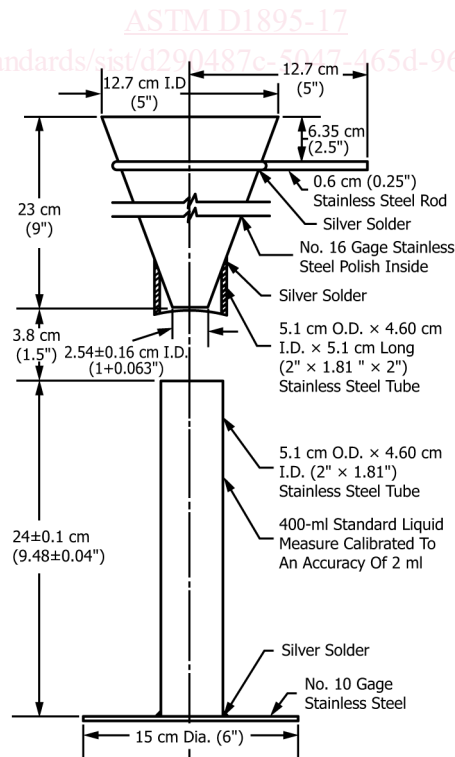

FIG. 2 Apparatus for Apparent Density Test, Method B

10. Procedure

10.1 With the apparatus assembled as shown in Fig. 2, close the small end of the funnel with the hand or with a suitable flat strip and pour a $500 \pm 20\text{-cm}^3$ sample into the funnel. Open the bottom of the funnel quickly and allow the material to flow freely into the cup.

NOTE 7—The funnel described in Test Method B is also used for more finely divided powders such as vinyl resins. While these powders usually will pour through this funnel, they may bridge in the 400-cm^3 cup shown in Fig. 2. To avoid this, the 100-cm^3 cup shown in Fig. 1 may be substituted, and the sample reduced to $115 \pm 5\text{ cm}^3$.

10.2 After all the material has passed through the funnel, immediately scrape off the excess on the top of the cup with a straightedge without shaking the cup. Weigh the material in the cup to the nearest 0.1 g; then calculate the weight in grams of 1 cm^3 of the material. Make three determinations of the apparent density on each sample and average the results (Note 23).

Test Method C

11. Scope

11.1 Test Method C (see Note 1) covers the measurement of the apparent density of materials supplied in the form of coarse flakes, chips, cut fibers, or strands. Such materials cannot be poured through the funnels described in Test Methods A and B. Also, since they ordinarily are very bulky when loosely poured and since they usually are compressible to a lesser bulk, even by hand, a measure of their density under a small load is appropriate and useful.

11.1 Test Method C (see Note 1) covers the measurement of the apparent density of materials supplied in the form of coarse flakes, chips, cut fibers, or strands. Such materials cannot be poured through the funnels described in Test Methods A and B. Also, since they ordinarily are very bulky when loosely poured and since they usually are compressible to a lesser bulk, even by hand, a measure of their density under a small load is appropriate and useful.

12. Apparatus

12.1 Measuring Cylinder—A cylinder of 1000-cm^3 capacity, as shown in Fig. 3.

12.2 Weight Plunger—A cylinder closed at one end and having an outside diameter slightly smaller than the inside diameter of the measuring cylinder, as shown in Fig. 3. The plunger shall have a scale cut on the outside surface, graduated in intervals of 1 mm.

13. Procedure

13.1 Place the measuring cylinder on a piece of paper. Loosely drop $60 \pm 0.2\text{ g}$ of the material to be tested into the measuring cylinder from a height approximately that of the cylinder, taking care to lose none of the material and to drop it as uniformly as

<https://standards.iteh.ai/catalog/standards/sist/d290487c-5047-465d-9664-bb50e8e62ff6/astm-d1895-17>

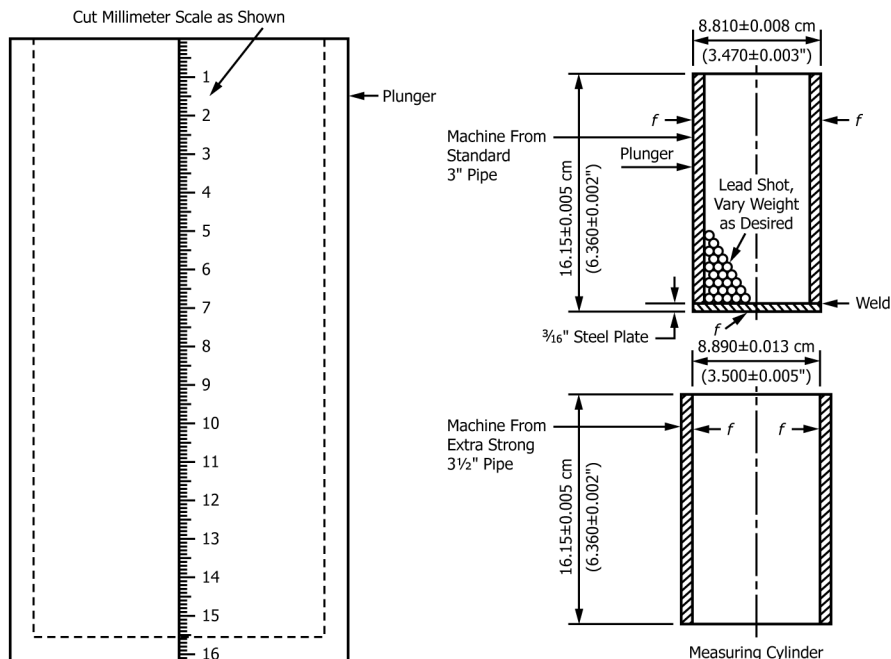

FIG. 3 Apparatus for Apparent Density Test, Method C