



Standard Test Method for Fire Test of Non-Mechanical Fire Dampers Used in Vented Construction¹

This standard is issued under the fixed designation E2912; the number immediately following the designation indicates the year of original adoption or, in the case of revision, the year of last revision. A number in parentheses indicates the year of last reapproval. A superscript epsilon (ϵ) indicates an editorial change since the last revision or reapproval.

1. Scope*

1.1 This fire-test-response standard assesses the ability of non-mechanical fire dampers used in vented construction in its open state to limit passage of hot gases, radiation, and flames during a prescribed fire test exposure. The fire exposure condition in this test method is sudden direct flame impingement, which produces these hot gases, radiation, and flames.

NOTE 1—Non-mechanical fire dampers can be used in vented construction. Vented constructions may be parts of buildings including walls, floors, ceilings and concealed spaces and cavities used for air transfer and to allow ventilation in structures without ductwork. Non-mechanical fire dampers can be located adjacent to combustible construction or materials and situated in exposed or concealed locations, or both. Unlike typical fire resistive assemblies, vented construction uses non-mechanical fire dampers to allow air transfer without the use of ducts. Resistance to flame, radiation, and hot gases may be requirements when direct flame impingement is a credible risk, or when no penetration of flames is required by the authority having jurisdiction, or both. The proposed test method provides procedures that enable an assessment of this direct flame impingement on non-mechanical fire dampers. This test method does not alter any requirements for non-mechanical fire dampers used in fire resistance rated construction and assemblies.

1.2 This fire-test-response standard is intended to provide a means to assess the reaction of a non-mechanical fire damper used in vented construction to sudden direct flame impingement, or as a supplement to existing fire-resistive test methods, or both.

1.3 This test method does not circumvent or eliminate the fire resistance rating requirements for construction. The fire resistance rating of construction shall be tested in accordance with published fire-resistance test standards as appropriate for the relevant application of the construction, or as required by the authority having jurisdiction (regulatory authority), or both. Non-mechanical fire dampers shall be tested to the appropriate fire-resistive test standards required for their application in order to determine a fire resistance rating in those constructions.

¹ This test method is under the jurisdiction of ASTM Committee E05 on Fire Standards and is the direct responsibility of Subcommittee E05.14 on External Fire Exposures.

Current edition approved Aug. 1, 2017. Published September 2017. Originally approved in 2013. Last previous edition approved in 2013 as E2912-13. DOI: 10.1520/E2912-17.

NOTE 2—Some of the major international standards development organizations (SDO) include, but are not limited to, ASTM International, CEN, ISO, UL, and ULC. Some examples of standards employing standard time-temperature curves for fire exposure used to determine a construction's fire resistance rating include, but are not limited to, the following: Test Methods E119, E814, E1966, E2307, UL 10B, UL 10C, UL 555, UL 555C etc. The term "authority having jurisdiction" is defined in Practice E2174.

1.4 This test method specifies the fire exposure conditions, fire test protocol, and criteria to evaluate an open state.

NOTE 3—There are currently no published test methods (nationally or internationally) that address the application of sudden direct flame impingement on non-mechanical fire dampers used in vented construction. In the European Union (EU), CEN (European Committee for Standardization) has very recently started a work item to address reaction to sudden direct flame impingement on non-mechanical fire dampers. Also, in the EU, some countries have used large scale tests with 5MW fire exposures to assess test specimens' reactions to sudden direct flame impingement as part of the entire building construction. Standard time-temperature curves used to control gas-fired furnaces do not ensure a sudden direct flame impingement on the test specimen, which this test method is designed to do. A post flashover condition, the spontaneous combustion of materials, ignition of a highly combustible material acting as the source of the fire (for example, stored cleaning solutions or fuels) or the location of materials can create a fire scenario resulting in a sudden direct flame impingement.

1.5 Results generated by this test method provide the following information:

1.5.1 the open state fire performance of vented construction, and

1.5.2 the non-mechanical fire damper's fire-test-response characteristic when exposed to sudden direct flame impingement.

1.6 This test method does not provide quantitative information about the test assembly related to the leakage of smoke, or gases, or both.

1.7 This test method does not apply to a test assembly having other components than those tested.

1.8 This standard is used to measure and describe the response of materials, products, or assemblies to heat and flame under controlled conditions, but does not by itself incorporate all factors required for fire hazard or fire risk assessment of the materials, products, or assemblies under actual fire conditions.

1.9 The text of this standard references notes and footnotes which provide explanatory material. These notes and footnotes

*A Summary of Changes section appears at the end of this standard

(excluding those in tables and figures) shall not be considered requirements of this standard.

1.10 The values stated in SI units are to be regarded as standard. No other units of measurement are included in this standard.

1.11 Fire testing is inherently hazardous. Adequate safeguards for personnel and property shall be employed in conducting these tests.

1.12 *This standard does not purport to address all of the safety concerns, if any, associated with its use. It is the responsibility of the user of this standard to establish appropriate safety, health and environmental practices and determine the applicability of regulatory limitations prior to use.*

1.13 *This international standard was developed in accordance with internationally recognized principles on standardization established in the Decision on Principles for the Development of International Standards, Guides and Recommendations issued by the World Trade Organization Technical Barriers to Trade (TBT) Committee.*

2. Referenced Documents

2.1 ASTM Standards:²

E119 Test Methods for Fire Tests of Building Construction and Materials

E176 Terminology of Fire Standards

E631 Terminology of Building Constructions

E814 Test Method for Fire Tests of Penetration Firestop Systems

E1966 Test Method for Fire-Resistive Joint Systems

E2174 Practice for On-Site Inspection of Installed Firestop Systems

E2257 Test Method for Room Fire Test of Wall and Ceiling Materials and Assemblies

E2307 Test Method for Determining Fire Resistance of Perimeter Fire Barriers Using Intermediate-Scale, Multi-story Test Apparatus

2.2 UL Standards:³

UL 10B Fire Tests of Door Assemblies

UL 10C Positive Pressure Fire Tests of Door Assemblies

UL 555 Fire Dampers

UL 555C Ceiling Dampers

3. Terminology

3.1 *Definitions*—Terms defined in Terminologies **E176** and **E631** shall prevail for fire and building terms not defined in this document.

3.1.1 For definitions of terms used in these test methods and associated with fire issues, refer to the definitions contained in Terminology **E176**.

3.1.2 For definitions of terms used in these test methods and associated with building issues, refer to the definitions contained in Terminology **E631**.

² For referenced ASTM standards, visit the ASTM website, www.astm.org, or contact ASTM Customer Service at service@astm.org. For *Annual Book of ASTM Standards* volume information, refer to the standard's Document Summary page on the ASTM website.

³ Available from Underwriters Laboratories (UL), 2600 N.W. Lake Rd., Camas, WA 98607-8542, <http://www.ul.com>.

3.1.3 When there is a conflict between Terminology **E176** and Terminology **E631** definitions, Terminology **E176** definitions shall apply.

3.2 *Definitions of Terms Specific to This Standard:*

3.2.1 *closed state, n*—the sealed or closed condition of an opening in vented construction.

3.2.2 *insulation, n*—ability of a test assembly, when exposed to fire on one side, to restrict the temperature rise to below specified levels on its unexposed side.

3.2.3 *integrity, n*—the ability of a test assembly, when exposed to fire from one side, to prevent the passage of flame or hot gases through it or the occurrence of flames on its unexposed side.

3.2.3.1 *Discussion*—In this test method the integrity of the test assembly is determined by Section 11, Integrity Test, and the Ignition Test Procedure in **Annex A2**.

3.2.4 *non-mechanical fire damper, n*—venting device used as part of vented construction intended to resist the transfer of hot gas, radiation, and flame.

3.2.5 *open state, n*—the unsealed or unclosed condition of the non-mechanical fire damper prior to being closed or sealed.

3.2.6 *open state fire performance, n*—the ability to limit the passage of hot gases, radiation, and flames produced during this test method's standardized, sudden-flaming exposure.

3.2.7 *splice, n*—a connection of parts of test specimens within the vented construction.

3.2.8 *test assembly, n*—the complete assembly of a test specimen(s) installed in the vented construction.

3.2.9 *test specimen, n*—a non-mechanical fire damper with specific attributes such as material(s), gaps, shapes, size, and width.

3.2.10 *vented construction, n*—a building element or construction feature (such as a floor, wall, roof, ceiling, joint, door or wall cavity, crawl space, air gap, etc.) that includes an opening(s) used for venting of spaces or as part of ductless ventilation equipped with one or more non-mechanical fire dampers.

4. Summary of Test Method

4.1 The test assembly is subjected to a standardized fire exposure created using a propane-powered gas burner regulated to a specific heat output as noted in **6.1.5**.

4.2 This test method is applicable to either horizontal or vertical test assemblies that are symmetrical or asymmetrical as referenced in **7.5** and **7.6**.

4.3 The test assembly is conditioned at specific temperature and humidity ranges as stated in Section 9.

4.4 This test method establishes a specific test procedure in Section 10 to measure the open state fire performance of vented construction when exposed to hot gases, radiation, and flames prior to, and including, its closed state.

4.5 This test method requires the time be reported at which flaming occurs, if any, as noted in **13.1.19** based on information obtained from **10.13**, **11.1**, and **11.2**.

4.6 The open state fire performance is monitored using an integrity test and an insulation test in accordance with Sections 11 and 12, respectively.

4.7 This test method requires the time be reported when individual and average unexposed surface temperature readings exceed the limitations established by this test method as noted in 13.1.20.

5. Significance and Use

5.1 This test method provides for the following observations, measurements and evaluations of an open state during the test fire.

5.1.1 Ability of the test specimen to resist the passage of flames, radiation, and hot gases caused by sudden direct flame impingement.

5.1.2 Transmission of heat through the test specimen.

5.2 This test method does not provide the following:

5.2.1 Evaluation of the degree to which the test assembly contributes to the fire hazard by generation of smoke, toxic gases, or other products of combustion.

5.2.2 Measurement of the degree of control or limitation of the passage of smoke or products of combustion through the test specimen or the test assembly.

5.2.3 Measurement of flame spread over the surface of the test specimen or the test assembly.

5.2.4 Durability of the test specimen or test assembly under actual service conditions, including the effects of cycled temperature.

5.2.5 Effects of a load on the test specimen or test assembly.

5.2.6 Any other attributes of the test specimen or the test assembly, such as wear resistance, chemical resistance, air infiltration, water-tightness, and so forth.

5.3 The results of this test method shall not be used as an alternative to, or a substitute for, requirements for a required fire resistance rating of building construction.

6. Apparatus

6.1 *Fire Source:*

6.1.1 A gas burner shall be used as the fire source.

6.1.2 The gas burner shall have a nominal 170 by 170 mm porous top surface consisting of a refractory material (for example, sand) as shown in Fig. 1. Unless otherwise specified, the tolerance for dimensions in figures shall be $\pm 5\%$.

NOTE 4—The burner and its output were selected to produce a sudden direct flame impingement on the test specimen that is constant. The burner configuration and its output were based upon those prescribed in Test Method E2257. The distance between the test specimen and the fire source (gas burner) was set to address variables typically seen in building occupation that contribute to sudden direct flaming. Two of many possible examples are: (1) Interior vents located in storage rooms and offices where combustibles are stacked on top of filing cabinets, (2) Exterior vents in

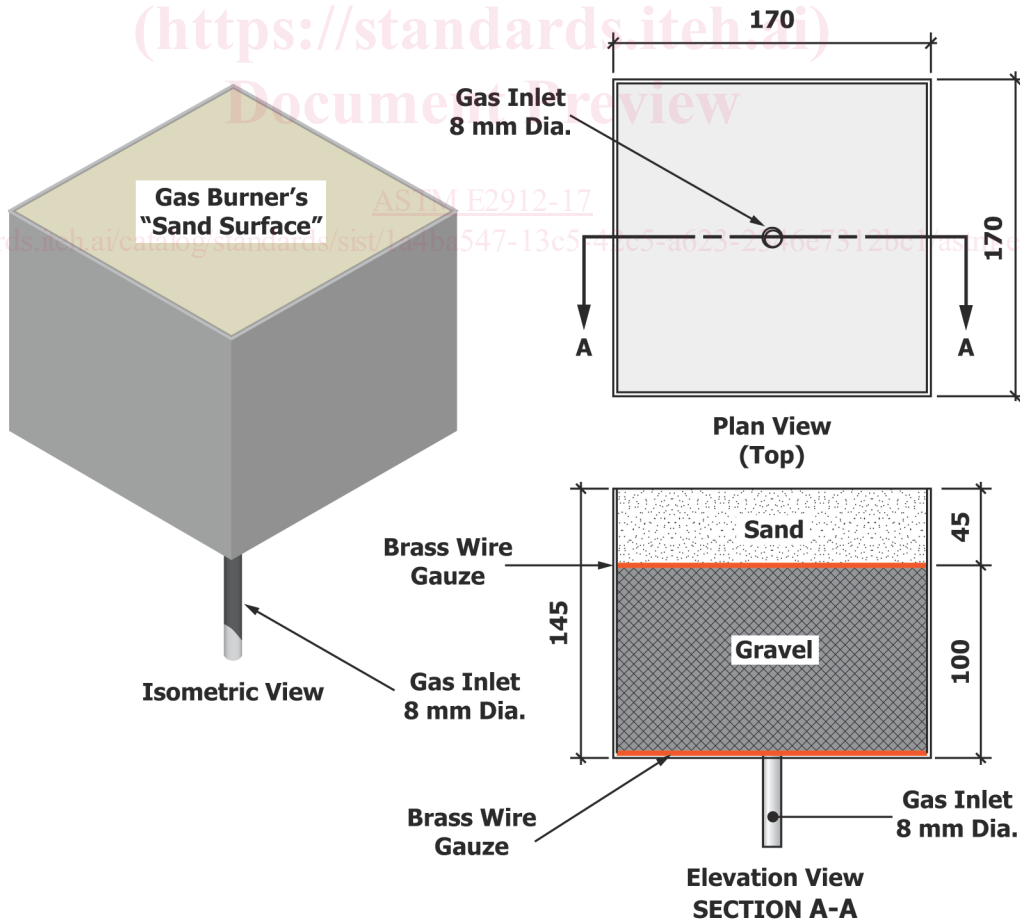

FIG. 1 Gas Burner Exposure Fire Source

contact with landscaping (vegetation or forestation, or both). In many cases, these combustibles are just inches from the vent, which is open to allow airflow, and are subject to a sudden direct flame impingement.

6.1.3 The burner shall be supplied with CP⁴ grade propane (99 % purity) with a net heat of combustion of 46.5 ± 0.5 MJ/kg. The gas flow to the burner shall be measured to an accuracy of at least ± 3 %. The flow measuring equipment shall be calibrated per the manufacturer’s instructions at least once per year.

6.1.4 The heat output to the burner shall be controlled within ± 5 % of the prescribed value.

6.1.5 The gas supply to the burner shall produce a constant net heat output of 300 ± 10 kW for at least 10 min.

6.2 *Test Bench:*

6.2.1 The test bench shall be constructed of framing and shall use materials suited to withstand the duration of the fire test. Unless otherwise specified, the tolerance for dimensions in figures and text in this section shall be ± 5 %.

6.2.2 The test bench shall have the following surface dimensions measured from inside the framing:

6.2.2.1 Length 2300 mm.

6.2.2.2 Width 1150 mm.

6.2.2.3 The overall length and width of the test bench will vary depending on the thickness of the framing and other materials used to construct the test bench.

NOTE 5—Wood framing and gypsum board have been found to be suitable materials with which to build a test bench. The wood framing should be protected from the heat source. However, other combinations of materials may also be appropriate for this use, such as steel framing, calcium silicate board, cement board, etc.

6.2.3 The test bench shall be constructed to have the dimensions and characteristics illustrated in Figs. 2-7, inclusive.

6.2.3.1 The test bench surface shall have a 500-mm square opening located as illustrated in Fig. 4.

6.2.3.2 A 600-mm skirt shall cover the two sides and the front of the test bench as illustrated in Figs. 5-7.

⁴ Commonly called commercial propane.

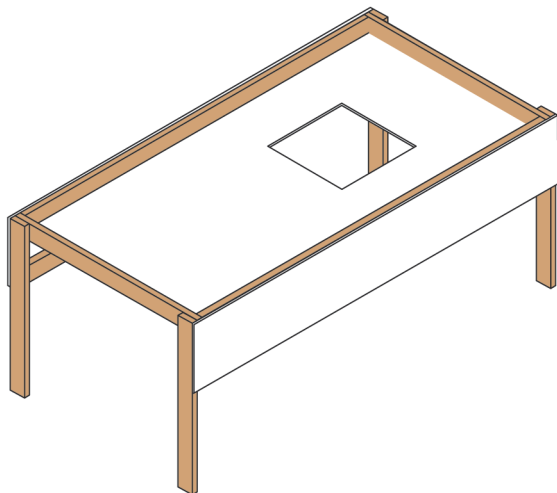

FIG. 2 Left Isometric View of Test Bench

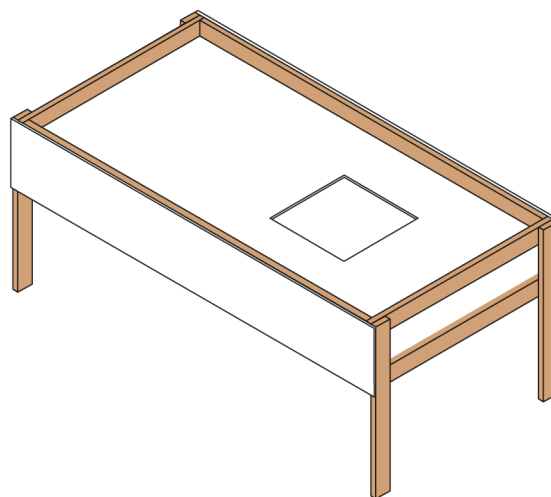

FIG. 3 Right Isometric View of Test Bench

6.2.3.3 *Discussion*—Excessive flue gas is also channeled out the open end of bench by the skirts. The side skirts are intended to provide some shielding for laboratory personnel from the effects of the gas burner. However, the laboratory shall implement additional safeguards as necessary to ensure laboratory personnel safety. The skirt is also used to avoid flames circumventing the opening in the test bench and affecting the unexposed side of the test specimen.

6.2.4 The height of the test bench shall be as necessary to meet the clearance dimensions illustrated in Fig. 8.

6.2.5 Fig. 4 and Fig. 8 show the test bench top surface, with the 500-mm square opening.

6.2.6 The top surface of the gas burner, referred to as the gas burner’s “sand surface” in Fig. 4 and Fig. 8, shall be positioned parallel to the bottom surface of the test bench as illustrated in Fig. 8.

6.2.7 Locate the gas burner’s sand surface a distance of 250 mm below the bottom surface of the test bench, as shown in Fig. 8, and center the burner in the 500-mm square opening as shown in Fig. 4 and Fig. 8, creating a concentric annular space of 165 mm around the gas burner in the plan view.

6.3 *Cotton Pads and Applicator Frame:*

6.3.1 Refer to Annex A1 for drawings and descriptions.

6.4 *Unexposed Surface Thermocouples:*

6.4.1 The wires for the thermocouple in the length covered by the pad shall be not heavier than No. 18 B&S gage (1.02 mm) and shall be electrically insulated with heat-resistant or moisture-resistant coatings, or both.

6.5 *Thermocouple Pads:*

6.5.1 The insulating pads shall be dry, felted, refractory fiber pads.

6.5.2 The pads shall be 9.5 ± 1.6 mm thick.

6.5.3 The pads length and width shall measure 50 ± 1 mm.

6.5.4 The pads shall have a density of 500 ± 10 kg/m³.

6.6 *Other Temperature Detection Devices:*

6.6.1 A visual imaging camera or calibrated thermal imaging camera is permitted to be used as an additional means of observation of flame penetration on the unexposed surface of the test specimen.

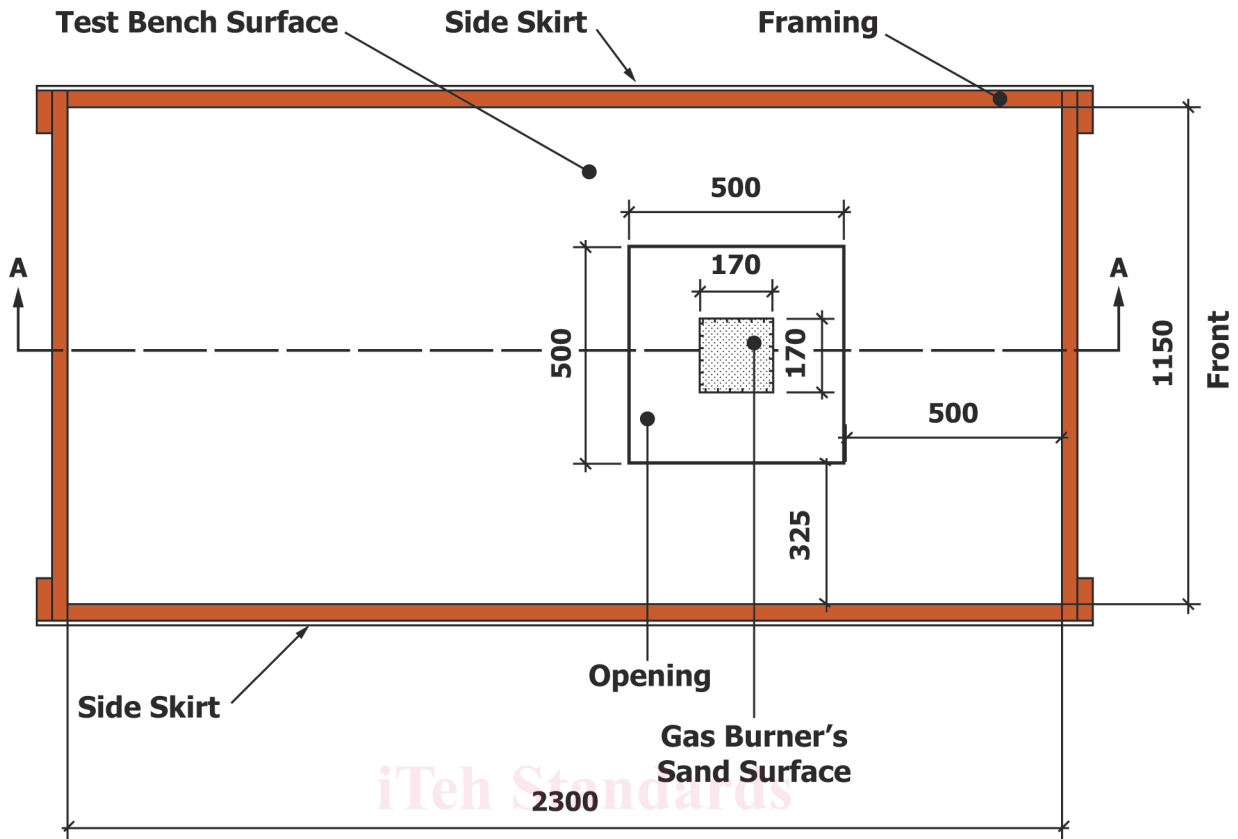

FIG. 4 Plan View of Test Bench

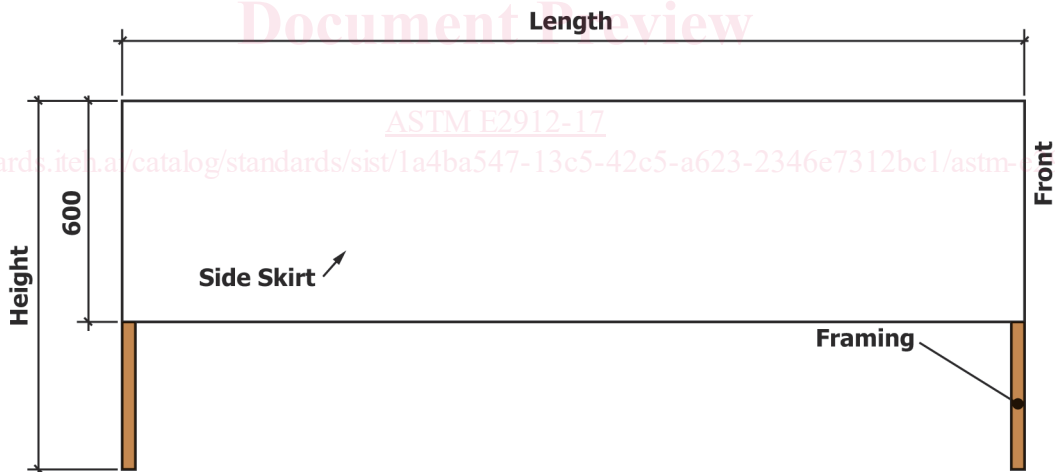

FIG. 5 Side Elevation View of Test Bench

6.7 Time Measurement:

6.7.1 A computer chronograph used as part of the temperature data acquisition equipment and either:

- 6.7.1.1 an electric clock with a sweep hand or
- 6.7.1.2 a digital clock.

7. Test Specimen and Test Assembly

7.1 The test assembly shall be representative of the vented construction and the test specimen shall be representative of the non-mechanical fire damper for which the open state fire

performance and the fire-test-response characteristic are to be recorded, with respect to materials, components, workmanship, and details.

7.2 Test Specimen Splices:

7.2.1 When a test specimen is able to be spliced during manufacture or in the field, or both, test the factory-manufactured splice and the field splice, as applicable. Photograph the splicing procedure and document the splicing instructions.

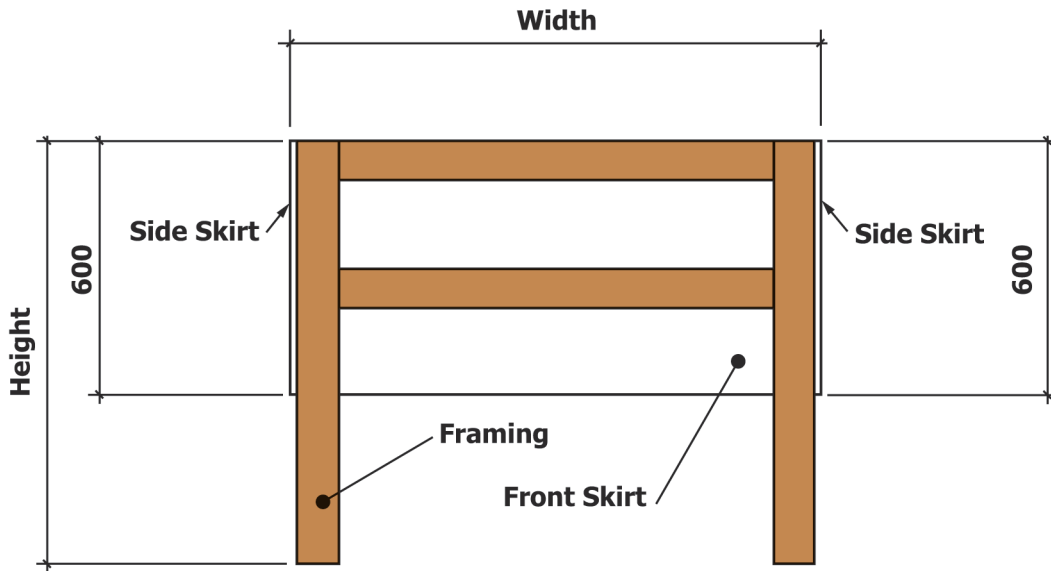

FIG. 6 Front Elevation View of Test Bench

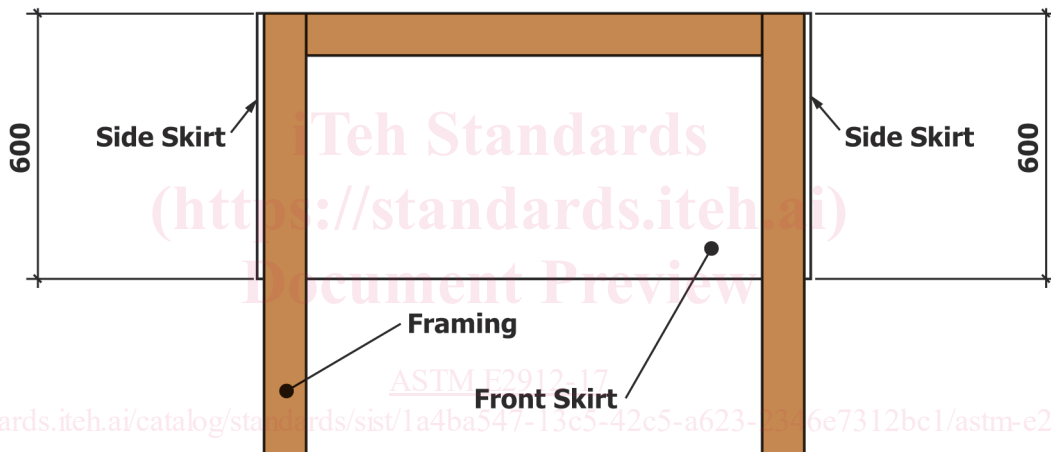

FIG. 7 Rear Elevation View of Test Bench

7.2.2 When the factory-manufactured splice is the same as the field splice technique, test one splice.

7.2.3 Position the splice in the middle of the test specimen. When testing splices position them equidistant in the length of the test specimen. The total area of the splices shall not exceed 25 % of the test specimen's area. No more than two splices shall be tested as part of the test specimen. The laboratory shall decide whether splices can be tested as part of the test specimen. When the laboratory believes that splices have the potential to increase performance of the test specimen, splices shall be tested separately.

7.2.3.1 *Discussion*—Calculate the splices' positions using the equation: $L/(x + 1)$. Where x is the number of splices to be created in the test specimen's length (L). Separate two splices by a distance of $L/3$.

7.2.4 When applicable to the end use of the test specimen, test each type of end sealing condition. Photograph the sealing procedure and document the sealing instructions.

7.3 Test Specimen Size:

7.3.1 The test specimen shall be 500 mm long (L) or high (H) by 500 mm wide (W).

7.3.2 When the test specimen's maximum dimensions are less than those required in 7.3.1, test the maximum length and width of the test specimen.

7.3.3 Document the dimensions of the test specimen tested.

7.4 Test Specimen Installation:

7.4.1 Install the test specimen into the test assembly in accordance with the manufacturer's installation instructions. Photograph the installation procedure and document the installation instructions. Document whether the test specimen and test assembly are symmetrical or asymmetrical.

7.5 Horizontal Test Specimens:

7.5.1 Horizontal test specimens used in horizontal assemblies (for example, floors, roofs, or ceilings) shall be installed as intended for use. Refer to Fig. 11 for various locations of horizontal test specimens that create symmetrical and asymmetrical test assemblies.