



Designation: D8132/D8132M – 17

Standard Test Method for Determination of Prepreg Impregnation by Permeability Measurement¹

This standard is issued under the fixed designation D8132/D8132M; the number immediately following the designation indicates the year of original adoption or, in the case of revision, the year of last revision. A number in parentheses indicates the year of last reappraisal. A superscript epsilon (ϵ) indicates an editorial change since the last revision or reappraisal.

1. Scope

1.1 This test method determines the in-plane permeability of composite prepreg (pre-impregnated) materials as a measure of level of impregnation. Permissible prepreg materials include those reinforced with carbon, glass, aramid, thermoplastic and other fibers impregnated with a thermoset or thermoplastic matrix resin, creating a single ply sheet material. The reinforcements may be unidirectional or woven fabrics.

1.2 The values stated in either SI units or inch-pound units are to be regarded separately as standard. The values stated in each system may not be exact equivalents; therefore, each system shall be used independently of the other. Combining values from the two systems may result in non-conformance with the standard.

1.2.1 Within the text, the inch-pound units are shown in brackets.

1.3 *This standard does not purport to address all of the safety concerns, if any, associated with its use. It is the responsibility of the user of this standard to establish appropriate safety, health and environmental practices and determine the applicability of regulatory limitations prior to use.*

1.4 *This international standard was developed in accordance with internationally recognized principles on standardization established in the Decision on Principles for the Development of International Standards, Guides and Recommendations issued by the World Trade Organization Technical Barriers to Trade (TBT) Committee.*

2. Referenced Documents

2.1 *ASTM Standards:*

D883 Terminology Relating to Plastics

D3878 Terminology for Composite Materials

E122 Practice for Calculating Sample Size to Estimate, With Specified Precision, the Average for a Characteristic of a Lot or Process

E177 Practice for Use of the Terms Precision and Bias in

¹ This test method is under the jurisdiction of ASTM Committee D30 on Composite Materials and is the direct responsibility of Subcommittee D30.03 on Constituent/Precursor Properties.

Current edition approved Aug. 1, 2017. Published September 2017. DOI: 10.1520/D8132_D8132M-17

ASTM Test Methods

E456 Terminology Relating to Quality and Statistics

E691 Practice for Conducting an Interlaboratory Study to Determine the Precision of a Test Method

3. Terminology

3.1 *Definitions*—Terminology D3878 defines terms relating to high-modulus fibers and their composites. Terminology D883 defines terms relating to plastics. Terminology E456 and Practice E177 define terms relating to statistics. In the event of a conflict between terms, Terminology D3878 shall have precedence over the other terminologies.

3.2 *Definitions of Terms Specific to This Standard:*

3.2.1 *as cast*—pertaining to the transparent and smooth surface of an acrylic block.

3.2.2 *acrylic block assembly*—the acrylic blocks nested together or clamped together but that are otherwise oriented or joined together only for a temporary process.

3.2.3 *cut side*—machined surface of an acrylic block.

3.2.4 *permeability*—Material property that determines flow through a porous medium. Used to determine the air transport of prepreg materials in the in-plane directions.

3.2.5 *permeability test apparatus*—the vacuum test chamber with known volume where the permeability test specimen is mounted and tested to determine permeability.

3.2.6 *permeability test specimen*—the vacuum test chamber with known volume where the permeability test specimen is mounted and tested to determine permeability.

3.3 *Symbols*

A = cross-sectional area of the prepreg test specimen

CV = coefficient of variation statistic of a sample population for a given property (in percent)

FAW = fiber areal weight

H = prepreg thickness

ID = inner diameter

K = permeability

K_n = normalized permeability (independent of prepreg thickness)

L = length of prepreg sample

OD = outer diameter

P = absolute pressure in vacuum chamber (P as a function of time)

P_{atm} = actual atmospheric pressure

P_i = initial absolute pressure in vacuum chamber (P_{iabs} at time 0)

RH = relative humidity

S_{n-1} = standard deviation statistic of a sample population for a given property

x_j = test result for an individual specimen from the sample population for a given property

\bar{x} = mean or average (estimate of mean) of a sample population for a given property

4. Summary of Test Method

4.1 This test method consists of imparting a pressure differential across a single ply of prepreg to determine the permeability of the material by exposing one side to the atmosphere and the other to known volume of reduced pressure. The initial reduced pressure, created by a vacuum pump, increases after the pump is shut off as a function of air flow through the prepreg. To create the test specimen, a single ply of prepreg is sandwiched and bonded between acrylic blocks. This test specimen is then attached to the surface of the known volume with vacuum tape. This assembly provides a leak-free seal and no applied compaction pressure on the prepreg surface during testing.

4.2 This standard defines a test method to determine the air transport capacity of a prepreg composite material in the plane of the fiber; in unidirectional materials, this means either parallel to or orthogonal to the fiber direction and in woven fabric materials, in the warp or fill direction.

4.3 A successful test is dependent on proper handling and mounting of the prepreg material sample. A leak-free seal is required between the prepreg and acrylic block adherends and to the surface of the test apparatus.

5. Significance and Use

5.1 It is well known that the prepreg impregnation level affects handling characteristics, tack and drape, and final part quality. Resin impregnation level is the dominant factor in the ability of removing air and volatiles from the layup during processing. Partially impregnated prepreg materials can in some applications provide higher quality, lower void content composite parts, and are becoming increasingly more common due to the desire to cure out-of-autoclave, using vacuum bag-only processes. This test can identify small changes in the material impregnation level which can assist in definition of production processes or shipping and handling procedures. The value of permeability can be used for specifying ranges as acceptance requirements for prepreg materials, thus enabling the prepreg manufacturer and user greater confidence in the ability to produce repeatable, high quality parts. This test directly determines the actual air flow propensity of the material tested without any applied compaction pressure during testing.

5.2 Factors that influence the permeability of the tested prepreg material shall be reported including: prepreg material,

orientation, location on roll, width, length, thickness, and actual atmospheric pressure.

6. Interferences

6.1 *Material and Specimen Preparation*—Poor material fabrication practices, lack of control of fiber alignment, and damage induced by improper specimen cutting are known causes of high data scatter in composites in general. Specific factors that affect the prepreg test specimen permeability results include compression and bending of prepreg, handling, sharpness of cutting blades, and control of fiber alignment and orientation when cutting. Measuring prepreg thickness is very difficult and subjective due to the viscoelastic material and non-uniform surface and can cause significant permeability calculation error. When comparing values at different laboratories, a normalized permeability value that does not take into account prepreg thickness may be more applicable.

6.2 *Permeability Test Specimen Preparation*—To maintain a high quality seal to the prepreg material it is important to have clean bonding surfaces on the acrylic blocks. Also the viscosity, gel, and cure time of adhesive, time to apply adhesive and mount specimen, and adhesive quantity can affect the seal or cause undesired impregnation of areas of the prepreg. The adhesive must fill in the bond line between the two acrylic block adherends or there can be a gap that is difficult to seal from the environment. Control of the orientation of the prepreg between the acrylic blocks is necessary for repeatable results. Once the prepreg is mounted and adhered between the acrylic blocks, the test specimen should be allowed to cure without pressure on the prepreg. Ends of the mounted prepreg should never be touched except for cutting immediately before testing.

6.3 *Mounting Blocks and Adhesive*—The mounting blocks that are specified are based on cast clear acrylic which enables inspection of the bond line. Other clear polymer blocks may be used but adhesion would need to be evaluated with the mounting adhesive

6.4 *Mounting Permeability Test Specimen to Apparatus*—The completed test specimens must be mounted with the prepreg centered so as not to touch the sides of the apparatus. An air-tight seal must be maintained throughout the testing.

6.5 *Barometric Pressure*—The barometric pressure that is used for the calculation of permeability must be the actual barometric pressure in the ambient testing environment and not a corrected barometric pressure. All pressure units used for calculations must be in absolute values.

6.6 *Geometry*—Specific geometric factors that affect permeability results include prepreg thickness, width, length, and orientation.

6.7 *Environment*—Results can be affected by large variations in environmental conditions under which the tests are conducted. Sample preparation and testing in humidity (RH) over 70% and temperatures above 23.9 °C [75 °F] or below 15.6 °C [60 °F] are not recommended.

7. Apparatus

7.1 *Test Apparatus*—Test apparatus is according to drawing (Fig. 1) starting with a stainless-steel cylinder that is approximately 51 mm [2.0 in.] outer diameter (OD) by 115 mm [4.50 in.] long. One end of the cylinder is machined from the center resulting in a hollow right cylinder extending 69.85 mm [2.75 in.] from one end. Holes are bored according to drawing (Fig. 1) and tapped to attach vacuum gage and valve fitting. A mounting/base plate to support the hollow cylinder in the upright position is recommended for stability. This can be made from one of many designs and is not critical as long as it enables the top of the hollow cylinder to be upright and stable. A 6.35 mm [0.25 in.] thick plate, 150 mm [6.0 in.] by 205 mm [8.0 in.] is very effective. Two holes are bored through the 6.35 mm [0.25 in.] plate located 50.8 mm [2.0 in.] from the long end and one each at 63.5 [2.5 in.] from each edge. None of these dimensions is critical to the apparatus function. It is necessary that the hole-size clearance is large enough to accommodate the selected bolt. To mount the cylinder to the base plate, two holes are drilled and tapped at the bottom of the cylinder.

To complete the apparatus, a digital vacuum gage with a 0.25 in. MNPT is attached directly to one of the 0.25 in. FNPT tapped holes and a fitting and valve attached on the opposite side. All threads should be sealed with anaerobic pipe thread sealant to ensure an air tight seal. The digital vacuum gage should be capable of accuracy $\pm 0.25\%$ full scale and display at least 5 display digits. On the other side of the cylinder a hex nipple 0.25 in. MNPT, 25.6 mm [1.01 in.] long, should be

attached. To this hex nipple a valve capable of maintaining a leak free seal under vacuum is attached. A one piece stainless ball valve 0.25 in., FNPT (2 ports) is recommended. The other side of the valve can be connected to a quick disconnect or directly threaded into the vacuum line. A completed apparatus mounted to a baseplate is shown in Fig. 2.

The total volume of the completed vacuum chamber apparatus from the closed valve to the top of the open cylinder needs to be calculated or determined from filling with appropriate density fluid. The total volume with fittings should be between 85 to 90 cm³ [5.1 to 5.5 in.³].

7.2 *Vacuum Pump*—2 to 3 CFM and capable of achieving within 3% of actual barometric pressure.

7.3 *Vacuum Hose*—Connect to fittings/ports on vacuum pump and apparatus.

7.4 *Digital Stopwatch*—Accuracy ± 0.01 s.

7.5 *Micrometers and Calipers*—A micrometer with a 4 to 7 mm [0.16 to 0.28 in.] nominal diameter ball interface or a flat anvil interface shall be used to measure the specimen thickness. A ball interface is recommended for thickness measurements when at least one surface is irregular (e.g. a coarse peel ply surface which is neither smooth nor flat). A micrometer or caliper with a flat anvil interface shall be used for measuring length, width, and other machined surface dimensions. The use of alternative measurement devices is permitted if specified (or agreed to) by the test requestor and reported by the testing laboratory. The accuracy of the instrument(s) shall be suitable for reading to within 1 % of the specimen dimensions. For

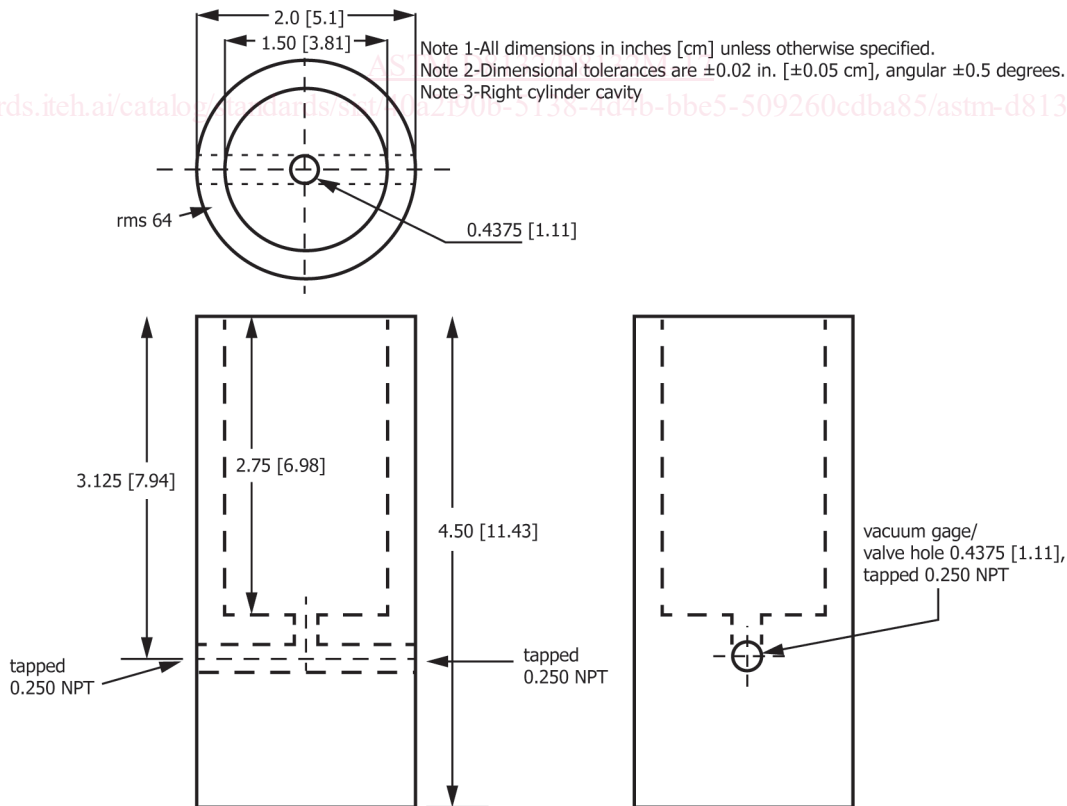

FIG. 1 Apparatus Design

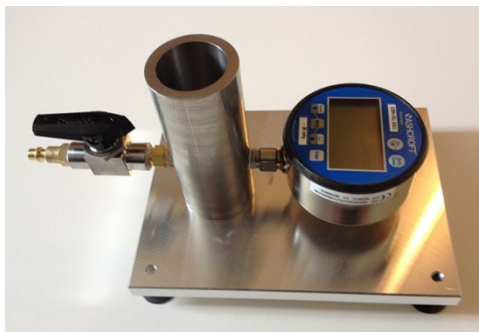

FIG. 2 Completed Apparatus (Shown Mounted to a Base for Stability)

typical specimen geometries, an instrument with an accuracy of ± 0.0025 mm [± 0.0001 in.] is adequate for thickness measurements, while an instrument with an accuracy of ± 0.025 mm [± 0.001 in.] is adequate for measurement of length, width, and other machined surface dimensions.

7.6 Barometer—Capable of reading actual barometric pressure with a range appropriate for elevation and resolution of 0.01 in. Hg [1 mbar].

7.7 Acrylic Blocks—Blocks of cast acrylic with dimensions approximately 24 mm \times 24 mm \times 76.2 mm [0.944 in. \times 0.944 in. \times 3 in.] for mounting prepreg. These can be cut from one inch thick cast acrylic sheet. Note one inch cast acrylic sheet is really 0.944 in. thick.

7.8 Adhesive—Two part, 5 min cure epoxy. Used to adhere the prepreg to the acrylic blocks.

7.9 Sealant Tape—Sealant tape used for vacuum bag development for composite processing. Use to attach the acrylic block prepreg assembly sample to the open top rim of the apparatus cylinder.

8. Sampling and Test Specimens

8.1 Sampling—The number of tests and location of specimens is determined by the test requestor. If not specified, at least five specimens should be tested unless valid results can be gained through the use of fewer specimens, as in the case of a designed experiment. For a roll of prepreg, often both edges and middle require testing but may also include beginning and end of rolls. For statistically significant data, consult the procedures outlined in Practice E122. Report the method of sampling.

8.2 Geometry—Prepreg test specimens shall be 76.2 mm long by 25.4 mm wide [3.0 in by 1.0 in.]. The samples may be cut from a roll or sheet of prepreg with the location defined and documented. In unidirectional prepreg materials, the orientation of the 76.2 mm [3.0 in.] dimension is defined by the testing request, but the fiber direction is standard. Caution associated with touching or pressure application on the area of the material to be tested shall be exercised at all times.

8.3 Specimen Preparation and Cutting—Specimen preparation is extremely important for this test method. Take precautions when cutting specimens from rolls to avoid pressing and compaction on the prepreg surface. It is recommended that the samples are cut at temperatures between 23.9 °C [75 °F] and

15.6 °C [60 °F]. Higher temperatures may increase tackiness of the prepreg and reduce integrity, altering impregnation at the cut ends or distortion. Cut samples parallel to fibers using a utility knife with sharp blade and across fibers using fabric shears. When using the fabric shears, it is best to perform the cutting action as fast as can be controlled. Only handle the prepreg with gloves and hold all 76.2 mm [3.0 in.] long samples by the ends. Make sure the samples don't bend or cup. Leave release liner on prepreg sample until mounting. Both prepreg ends will be cut off immediately before testing. Edges should be flat and parallel within the specified tolerances. Record and report the specimen cutting preparation method. Measure and record sample length and width using calipers and prepreg thickness using a micrometer. Perform all measurements so as not to compress or distort the prepreg sample. Measure the prepreg thickness on an end that will be discarded, prior to testing.

8.4 Labeling—Label the unmounted test specimens after cutting so that they will be distinct from each other and traceable back to the material of origin. Also include the out time of the prepreg on the label. A recommended method is to label a small piece masking tape and attach to one end the specimen. This should not extend more than a 6.35 mm [0.25 in.] from the end. Another method is to directly label the release liner using contrasting ink pen but if this is done it should be no more than 6.35 mm [0.25 in.] from one end of the specimen. This area will be cut off the specimen before testing since labeling can distort or compress the prepreg.

8.5 Sample Mounting—To create the test specimen, the prepreg sample must be mounted between acrylic blocks to create a flat planar surface for attaching to the apparatus. Obtain two clean acrylic blocks, as described in subsection 7.7 and remove protective paper/plastic if still on the blocks. Label acrylic blocks with prepreg sample identification. Mix thoroughly approximately 10 g of adhesive described in subsection 7.8 in a clean container according to manufacturer directions. It is recommended that the assembly bonding temperature is room temperature. After adhesive is thoroughly mixed, spread a thin and consistent layer immediately on one cut side of each block. Carefully remove release liner (backing) from prepreg sample. Hold prepreg sample by the ends since this will be cut off. Do not bend. Place prepreg sample in center on top of one adhesive coated block. The prepreg should extend over the edge of the block one inch. Place the other adhesive coated