



Designation: **C1265 – 94 (Reapproved 2011) C1265 – 17**

## Standard Test Method for Determining the Tensile Properties of an Insulating Glass Edge Seal for Structural Glazing Applications<sup>1</sup>

This standard is issued under the fixed designation C1265; the number immediately following the designation indicates the year of original adoption or, in the case of revision, the year of last revision. A number in parentheses indicates the year of last reapproval. A superscript epsilon ( $\epsilon$ ) indicates an editorial change since the last revision or reapproval.

### 1. Scope

1.1 This test method covers a laboratory procedure for quantitatively measuring the tensile strength, stiffness, and adhesion properties of insulating glass edge seals that are used in structural sealant glazing applications. Edge seals for these applications use a structural sealant to bond both glass lites and the edge spacer into a monolithic sealed insulating glass unit. In typical applications, the structural sealant acts to hold the outside lite in place under wind and gravity load and to maintain the edge spacer in its proper position. Hereafter, the term “insulating glass” will be abbreviated as “IG.”

1.2 The characterization of the IG secondary sealant properties, as defined by this test method, are strongly dependent on glass and edge spacer cleaning procedures, IG spacer profile, location of spacer, and primary IG sealant application. Users of this test method must recognize that the IG edge seal assembly influences the secondary sealant properties.

1.3 The values determined by this test method will be characteristic of the particular edge seal assembly that is tested.

NOTE 1—Presently, only elastomeric, chemically curing silicone sealants specifically formulated for use as the secondary seal of IG units are recognized as having the necessary durability for use in structural sealant glazing applications.

1.4 The values stated in SI (metric) units are to be regarded as the standard. The inch-pound values given in parentheses are approximate equivalents, provided for information purposes.

1.5 *This standard does not purport to address all of the safety concerns, if any, associated with its use. It is the responsibility of the user of this standard to establish appropriate safety, health, and environmental practices and determine the applicability of regulatory limitations prior to use.*

1.6 *This international standard was developed in accordance with internationally recognized principles on standardization established in the Decision on Principles for the Development of International Standards, Guides and Recommendations issued by the World Trade Organization Technical Barriers to Trade (TBT) Committee.*

### 2. Referenced Documents

2.1 *ASTM Standards:*<sup>2</sup>

**C717 Terminology of Building Seals and Sealants**

### 3. Terminology

3.1 *Definitions*—Refer to Terminology **C717** for definitions of the following terms used in this test method: *adhesive failure, cohesive failure, elastomeric, glazing, lite, primer, seal, sealant, silicone sealant, structural sealant, ~~substrate~~-substrate, standard conditions.*

### 4. Summary of Test Method

4.1 Five specimens are fabricated to duplicate the edge seal design of an IG unit for structural glazing applications. After the secondary structural sealant is cured the specimens are tested to failure in tension. Testing is conducted at  $23 \pm 2^\circ\text{C}$  ( $74 \pm 3.6^\circ\text{F}$ ) at a rate of  $5 \pm 0.5$  mm ( $0.2 \pm 0.02$  in.) per minute. Strength, load-displacement response, failure mode, and primary IG edge seal behavior are recorded.

<sup>1</sup> This test method is under the jurisdiction of ASTM Committee of **C24** on Building Seals and Sealants and is the direct responsibility of Subcommittee **C24.30** on Adhesion.

Current edition approved Dec. 1, 2014; Sept. 15, 2017. Published December 2014/October 2011. Originally approved in 1994. Last previous edition approved in 2005/2011 as **C1265-94(2005)C1265-94(2011)**. DOI: 10.1520/C1265-94R11; 10.1520/C1265-17.

<sup>2</sup> For referenced ASTM standards, visit the ASTM website, www.astm.org, or contact ASTM Customer Service at service@astm.org. For *Annual Book of ASTM Standards* volume information, refer to the standard's Document Summary page on the ASTM website.

5. Significance and Use

5.1 Frequently IG units are adhered with a structural sealant to a metal framing system. In such applications, only the inward lite of glass is usually adhered to the frame. As a result, a significant portion of any outward-acting or negative wind load must be carried in tension by the joint seal between the two lites of the IG unit. This test will not provide information on the integrity of the IG unit primary seal; however, it may provide data on load sharing between the primary IG vapor seal and the secondary structural sealant.

5.2 Although this test method prescribes one environmental condition, other environmental conditions and exposure cycles can be employed for specific project evaluation. Such deviations should be described when reporting the data.

6. Apparatus and Accessory Materials

6.1 *Tensile Testing Machine*, capable of producing a tensile load on the specimen at a rate of  $5.0 \pm 0.5$  mm ( $0.20 \pm 0.02$  in.) per minute. The machine shall be capable of measuring the load to  $\pm 4$  N ( $\pm 1$  lb). See Fig. 1.

6.1.1 *Fixed Member*—A fixed or essentially stationary member carrying a grip.

6.1.2 *Movable Member*—A movable member carrying a second grip.

6.1.3 *Grips*—The grips should be suitable to firmly grasp the test fixture that holds the test specimen and should be designed to minimize eccentric specimen loading. Specimen loading should be perpendicular to both glass substrates. A swivel or universal joint near one or both ends of the test specimen may be helpful for alignment purposes.

6.1.4 *Grip Fixture*—A fixture capable of being held by the grips and furnishing a tensile force to the joint specimen.

6.2 *Spatulas*, for use in applying sealant.

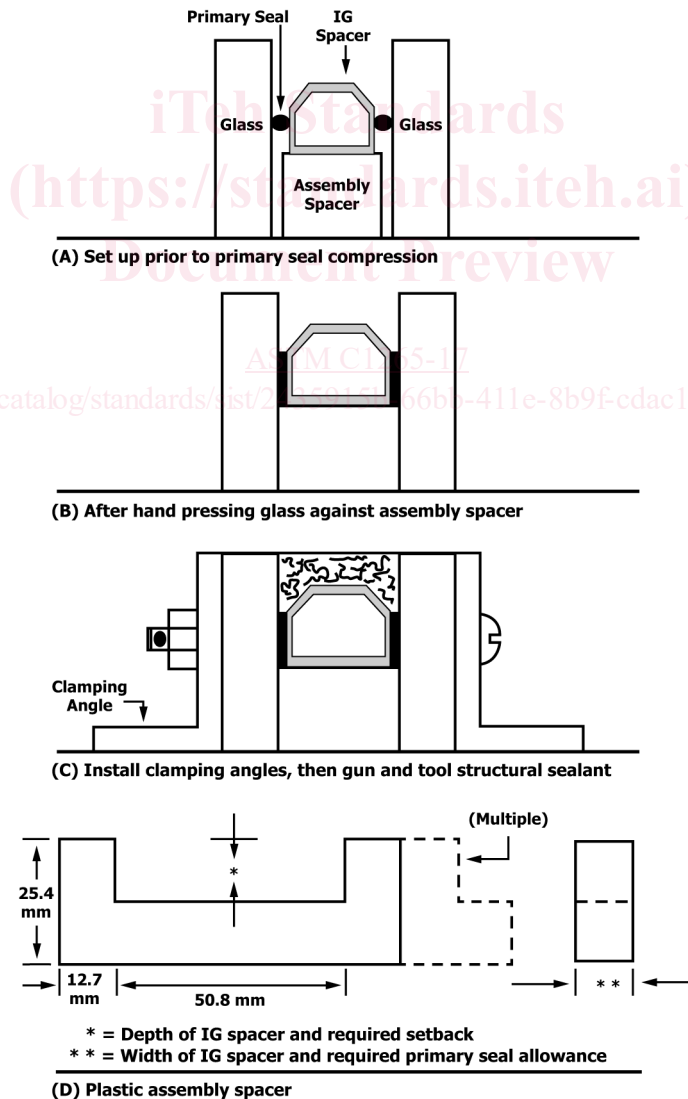

FIG. 1 Suggested Assembly Method

6.3 *Caulking Gun*, for extruding sealant from cartridges when applicable.

6.4 *Glass Substrates*, of the same type(s) as used in the joint design being evaluated.

NOTE 2—This test method is based on glass substrates of 6.3 by 25 by 76 mm (0.25 by 1.0 by 3.0 in.) in size. Other thicknesses may be tested; however, consideration should be given to preventing breakage or excessive bending of the glass during testing.

NOTE 3—The sample tested should reflect the actual IG unit edge construction; that is, glass with sensitive coatings should be tested as they are used. If a coating is edge-deleted in practice, it should be edge-deleted for the test.

6.5 *Edge Spacer*—The spacer should be identical in material, cross section, and surface finish to the spacer to be used in the IG edge seal design being evaluated.

6.6 *Primary Sealant*—This sealant or sealant tape, that is non-structural, provides a vapor seal for the IG unit. Its presence and configuration affects the geometry and behavior of many structural IG edge seal designs; therefore, it should be included as part of the specimen.

6.7 *Assembly Spacer(s)*—Spacer(s) or end blocks, or both, made from TFE-fluorocarbon or other suitable non-bonding material are used to maintain the proper specimen dimensions during specimen assembly. Because details of specimens tested by this test method will vary, it is not possible to define a single spacer or end block shape.

6.8 *Glass Substrate Cleaning Materials*:

6.8.1 *Primary*—Materials common to industry practice for the IG unit being evaluated.

6.8.2 *Alternate*—Clean, dry, lint-free cloths. A 0.1 % solution of clear hand dishwashing detergent.<sup>3</sup> The solution should be made up in distilled or deionized water.

6.9 *Edge Spacer Cleaning Materials*:

6.9.1 *Primary*—Materials common to industry practice of the IG unit being evaluated.

6.9.2 *Alternate*—Clean, dry, lint-free cloths. Isopropyl alcohol (99 %).

## 7. Test Specimen Assembly

7.1 *Assembly*:

7.1.1 *Glass Cleaning Procedure*:

7.1.1.1 Prior to assembly, clean the glass using the methods recommended by the manufacturer of the IG unit being evaluated.

7.1.1.2 When no manufacturer's cleaning guidelines are available, wipe substrates with a clean, dry, lint-free cloth, then thoroughly clean with a second clean, lint-free cloth and 0.1 % solution of a clear hand dishwashing detergent,<sup>3</sup> as described in 6.8. Rinse the surfaces (without touching them) in distilled or deionized water and allow to air dry.

7.1.2 *Edge Spacer Cleaning Procedure*:

7.1.2.1 Prior to assembly, clean the edge spacer using the methods used by the manufacturer of the IG unit being evaluated.

7.1.2.2 When no manufacturer's cleaning guidelines are available, wipe substrates with a clean, dry, lint-free cloth, then thoroughly clean with a second clean, lint-free cloth and diisopropyl alcohol (99 %) and allow to air dry.

7.1.3 Construct the test specimen assemblies by forming a sealant cavity 50 mm (2.0 in.) long, with a cavity width and depth as dictated by the joint design being evaluated. (See Fig. 2). Care should be taken to ensure that assembly of the substrate panels, IG joint spacer, and primary IG joint seal are representative of the actual joint design.

7.2 *Sample Preparation*:

7.2.1 Prepare a minimum of five specimens for each sealant, substrate, and geometry combination being tested, as shown in Fig. 2.

NOTE 4—Five test specimen assemblies should be prepared for each additional environmental condition being evaluated.

7.2.2 Each specimen in each set should be individually identified.

7.2.3 Fig. 1 shows a suggested approach to assembly of the two pieces of glass, the IG edge spacer, and the two primary IG edge seals prior to application of the secondary structural sealant. Special care must be given to accurate placement of all assembly components. Also, it is important that the final configuration (thickness, width, and position) of the primary IG edge seal match that seen in the actual joint design being evaluated. See Appendix X1 for a discussion of assembly procedures that have been found suitable.

7.2.4 Fill each assembly with the secondary structural sealant that is to be tested. Immediately tool the sealant surface to ensure complete filling of the cavity and wetting of the substrate surfaces. Take special care to strike off the sealant flush with the glass edges.

7.3 *Conditioning*:

<sup>3</sup> Dawn, made by Proctor and Gamble Co., P.O. Box 599, Cincinnati, OH 54201, and Palmolive Green, made by Colgate Palmolive Co., 300-T Park Avenue, New York, NY 10022, have been found suitable for this purpose.