

# INTERNATIONAL STANDARD

**ISO  
4091**

Second edition  
1992-10-01

---

---

## Road vehicles — Connectors for electrical connections between towing vehicles and trailers — Test methods and performance requirements

**iTeh STANDARD PREVIEW**  
**(standards.iteh.ai)**

*Véhicules routiers — Connecteurs pour connexions électriques entre  
véhicules tracteurs et remorques — Méthodes d'essai et caractéristiques  
de fonctionnement*

<https://standards.iteh.ai/catalog/standards/sist/1a6737e9-eba0-4969-b3d2-0dc55003d654/iso-4091-1992>



Reference number  
ISO 4091:1992(E)

## Foreword

ISO (the International Organization for Standardization) is a worldwide federation of national standards bodies (ISO member bodies). The work of preparing International Standards is normally carried out through ISO technical committees. Each member body interested in a subject for which a technical committee has been established has the right to be represented on that committee. International organizations, governmental and non-governmental, in liaison with ISO, also take part in the work. ISO collaborates closely with the International Electrotechnical Commission (IEC) on all matters of electrotechnical standardization.

Draft International Standards adopted by the technical committees are circulated to the member bodies for voting. Publication as an International Standard requires approval by at least 75% of the member bodies casting a vote.

International Standard ISO 4091 was prepared by Technical Committee ISO/TC 22, *Road vehicles*, Sub-Committee SC 3, *Electrical and electronic equipment*.

This second edition cancels and replaces the first edition (ISO 4091:1978) and its Addendum 1:1982, of which it constitutes a technical revision.

ITC STANDARD PREVIEW

(standards.iteh.ai)

<https://standards.iteh.ai/catalog/standards/sist/1a6737e9-eba0-4969-b3d2-000000000000/iso-4091-1992>

<https://standards.iteh.ai/catalog/standards/sist/1a6737e9-eba0-4969-b3d2-000000000000/iso-4091-1992>

© ISO 1992

All rights reserved. No part of this publication may be reproduced or utilized in any form or by any means, electronic or mechanical, including photocopying and microfilm, without permission in writing from the publisher.

International Organization for Standardization  
Case Postale 56 • CH-1211 Genève 20 • Switzerland

Printed in Switzerland

# Road vehicles — Connectors for electrical connections between towing vehicles and trailers — Test methods and performance requirements

## 1 Scope

This International Standard specifies test methods and performance requirements for all types of connectors used for electrical connections between towing vehicles and trailers.

NOTE 1 Dimensions and particular performance requirements due to the design of the connector are specified in separate standards.

## 2 Normative references

The following standards contain provisions which, through reference in this text, constitute provisions of this International Standard. At the time of publication, the editions indicated were valid. All standards are subject to revision, and parties to agreements based on this International Standard are encouraged to investigate the possibility of applying the most recent editions of the standards indicated below. Members of IEC and ISO maintain registers of currently valid International Standards.

ISO 1817:1985, *Rubber, vulcanized — Determination of the effect of liquids*.

ISO 9227:1990, *Corrosion tests in artificial atmospheres — Salt spray tests*.

## 3 Test methods

### 3.1 General requirements and pre-conditioning

3.1.1 All test sequences shall start with unused connectors, with plug and socket of the same manufacturer and type, and be carried out at an ambient temperature of  $23\text{ }^{\circ}\text{C} \pm 5\text{ }^{\circ}\text{C}$  and relative humidity of 45 % to 75 %, unless otherwise specified.

The connector shall be dry and clean. During the whole test sequence, no lubrication or other additional aid to reach better test results shall be permitted.

3.1.2 All test sequences shall be preceded by conditioning all samples of connectors, cables and test rods at  $23\text{ }^{\circ}\text{C} \pm 5\text{ }^{\circ}\text{C}$  and 45 % to 75 % relative humidity for a minimum period of 4 h.

### 3.2 Visual examination

First subject the sample plug and socket to a visual examination with the naked eye, corrected, if necessary, to give normal strength of vision and normal colour perception, at the most favourable viewing distance and with suitable illumination.

### 3.3 Mechanical test

#### 3.3.1 Static load test

Place the plug between two horizontal flat metal plates which overlap the specimen. Apply a static force of  $500\text{ N} \pm 2\%$  to the plates.

Carry out this test with the same specimen in every one of the positions in which it will rest naturally on the lower test plate.

#### 3.3.2 Locking device and cable retention strength test

Carry out the test with mated plug and socket, and the plug assembled with a 5 mm diameter metal rod which is coated with cable-quality PVC to give an outside diameter of 12 mm, fixed as if it were a cable. Apply a force increasing linearly within 10 s from 0 to 1 000 N to the test rod in the withdrawal direction. Maintain the value of 1 000 N for a subsequent 10 s.

**3.3.3 Insertion and withdrawal force test**

Carry out tests for insertion and withdrawal forces using suitable test apparatus.

The rate of travel for insertion and withdrawal shall be a constant speed not exceeding 100 mm/min.

Apply the force axially to the connector with the locking device disengaged and the cover not resting on the plug.

**3.3.4 Locking device operating test**

**3.3.4.1 Locking lever operating force**

Measure the operational force of the locking device at the centre point of the locking device operational area and in the direction specified by the manufacturer.

**3.3.4.2 Twist-lock operating torque**

Where twist-lock connectors are used, carry out the following test instead of that in 3.3.4.1.

Measure the torques required to engage, disengage and lock the twist-lock using a suitable measuring device, as for example a torque wrench with a suitable tensioning element applied to the coupling ring of the plug, scale division 0.2 N·m.

**3.3.5 Vibration test**

Mount the mated connector horizontally using a suitable device on a vibration test bench.

Connect a cable as used for normal operation to the plug. Support the cable only at 1 m from the socket front, independently from the vibration test bench, as shown in figure 1. For spiral cables, the cable length between plug and support shall be 4,5 m.

Connect one contact to a d.c. source allowing a current flow of 100 mA, to monitor contact resistance variation during the entire test (see figure 2).

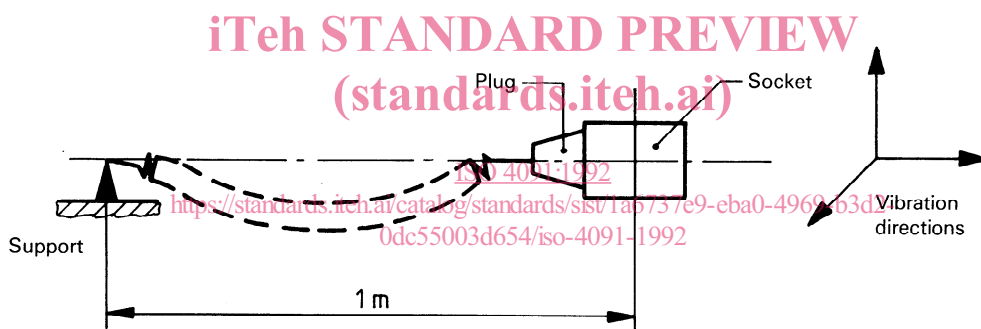

**Figure 1 — Vibration test**

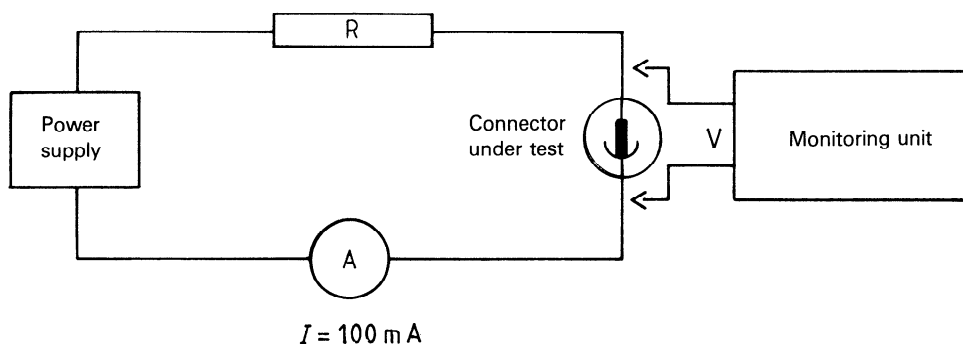

**Figure 2 — Resistance monitor**

Subject the assembled and mounted connector to sinusoidal vibrations of

- 5 Hz to 11 Hz at  $\pm 10$  mm constant amplitude; and
- 11 Hz to 200 Hz at  $50 \text{ m/s}^2$  acceleration.

The frequency variation shall be 1 octave/min.

Apply the motion for 16 h in each of the three mutually perpendicular directions, i.e. vibrate the connector first axially, followed by vibration laterally, and then vertically. The total test time is thus  $3 \times 16$  h for a total of 48 h.

### 3.3.6 Salt spray test

Carry out the test in compliance with the test procedure specified in ISO 9227 over 96 h. Test the connector in the following combinations:

- a) socket mated with the plug and locked;
- b) park socket mated with the plug and locked;
- c) socket and park socket with cover closed.

Sample tests shall be carried out using separate components. In each case, the test specimen shall be mounted horizontally with the cable(s) mounted and sealed as designed.

### 3.3.7 Water splash test

Carry out the test with the connector combinations as in 3.3.6 and using the test apparatus shown in figure 3.

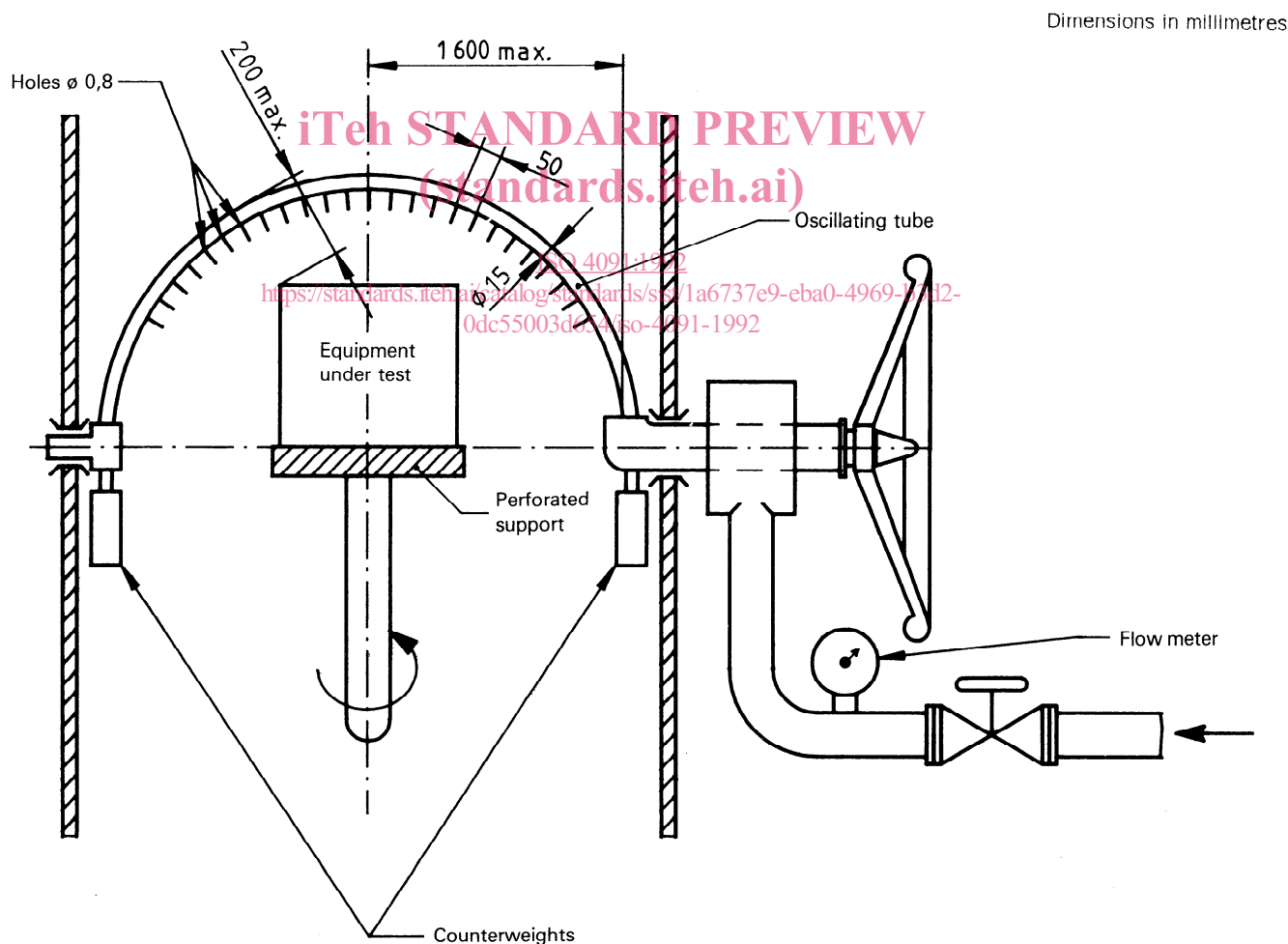

Figure 3 — Test apparatus for water splash test

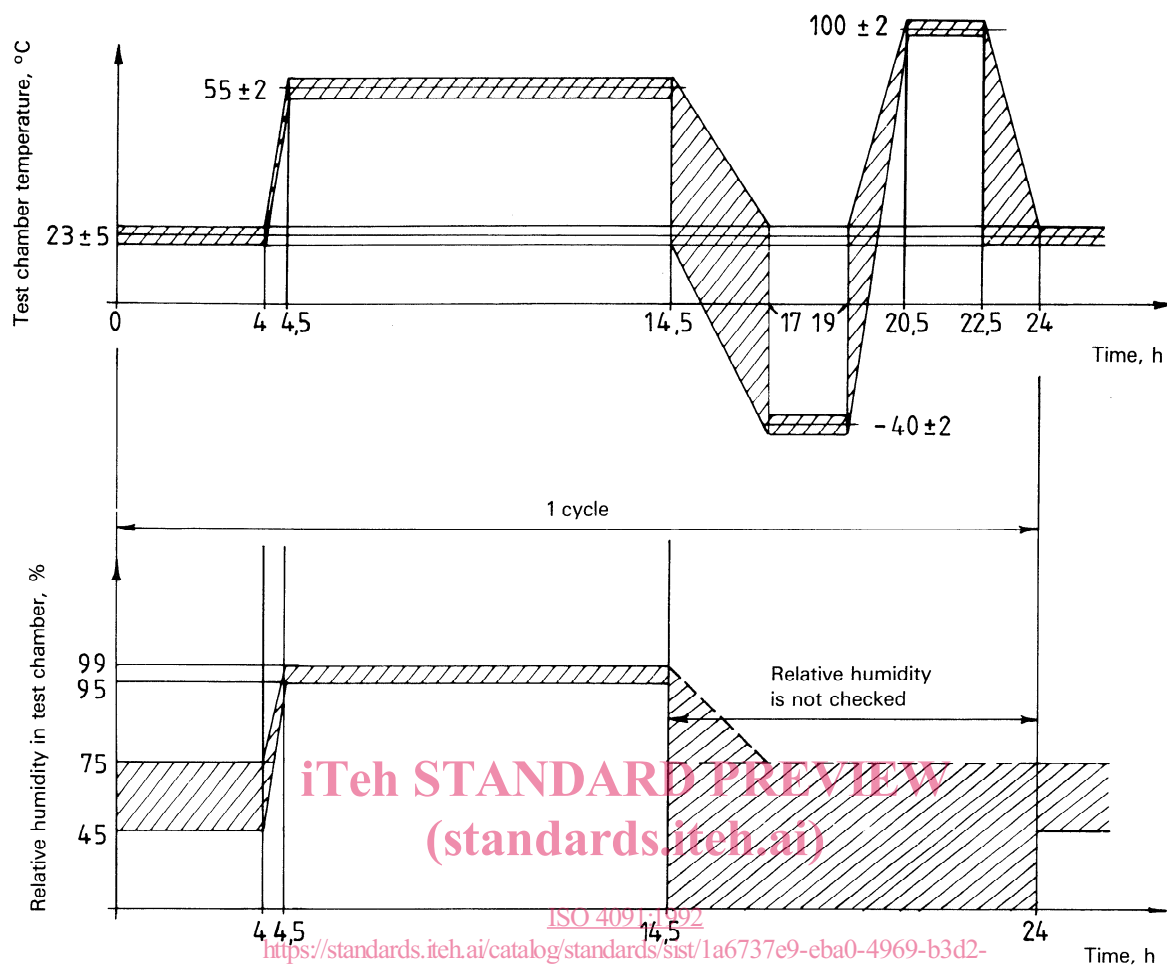

Figure 4 — Temperature/humidity test

The oscillating tube shall have holes of 0,8 mm diameter drilled at regular intervals over approximately  $150^\circ$ . The tube shall oscillate through an angle of almost  $360^\circ$ ,  $180^\circ$  to either side of the vertical. The oscillating speed shall be approximately  $90^\circ/\text{s}$ .

The water pressure shall be approximately 4 bar.

In each case, mount the test specimen horizontally with the cable(s) mounted and sealed as designed. Place the specimen in the test apparatus at the centre of the oscillating tube. The support shall be perforated so as to avoid acting as a baffle.

Subject each specimen to the water splash test for at least 10 min.

### 3.3.8 Temperature/humidity test

Carry out the temperature/humidity test with the mated connection. Subject the specimen to five cycles of 24 h, each as follows and within the limits shown in figure 4.

- Hold chamber temperature (CT) at  $23^\circ\text{C} \pm 5^\circ\text{C}$  for 4 h at 45 % to 75 % relative humidity (RH).
- Raise CT to  $55^\circ\text{C} \pm 2^\circ\text{C}$  at 95 % to 99 % RH within 0,5 h.
- Hold CT at  $55^\circ\text{C} \pm 2^\circ\text{C}$  at 95 % to 99 % RH for 10 h.
- Lower CT to  $-40^\circ\text{C} \pm 2^\circ\text{C}$  within 2,5 h.
- Hold CT at  $-40^\circ\text{C} \pm 2^\circ\text{C}$  for 2 h.
- Raise CT to  $100^\circ\text{C} \pm 2^\circ\text{C}$  within 1,5 h.
- Hold CT at  $100^\circ\text{C} \pm 2^\circ\text{C}$  for 2 h.
- Allow specimen to return to  $23^\circ\text{C} \pm 2^\circ\text{C}$  within 1,5 h.

#### NOTES

- During periods d), e), f), g) and h), the relative humidity is uncontrolled.

- 3 If necessary, step f) may be increased, thus shortening step a).
- 4 During the weekend, samples remain at  $23\text{ }^{\circ}\text{C} \pm 5\text{ }^{\circ}\text{C}$ .

**3.3.9 Lateral strength at low temperature**

Carry out the lateral strength test in a test chamber at  $-25\text{ }^{\circ}\text{C} \pm 2\text{ }^{\circ}\text{C}$ , socket and plug mated and mounted as designed. Fit the plug to a test rod as in 3.3.2 and apply the load to the extreme end, away from the mounting, of the connector assembly. Apply the load in four directions at  $90^{\circ}$  to each other, starting parallel to the cover hinge. The force applied shall be 200 N.

**3.4 Test of material specification**

Verify the material specifications by checking the guaranteed material features of the material manufacturer, in particular in relation to the following:

- base (5 % KOH, 25 %  $\text{K}_2\text{CO}_3$ , 70 %  $\text{H}_2\text{O}$ );
- test fuel (as specified in ISO 1817);
- lubricating oil No. 1 (as specified in ISO 1817);
- compression-ignition engine fuel;
- lubricating grease (as specified in ISO 1817);
- solar radiation (under study).

**3.5 Electrical tests**

**3.5.1 Current carrying capacity test**

Carry out the test simultaneously on two pairs of contacts (pin and tube) positioned adjacent in the connector. At least one of the contact pairs shall be connected with a cable of the maximum cross-sectional area specified for the connector under test.

Connect insulated test cables of  $500\text{ mm} \pm 5\text{ mm}$  length and a cross-sectional area as in table 1 to the terminals of each contact under test. Apply a test current as in table 1.

Over the test period of 1 h, monitor the contact temperatures, measured at the terminals as close as possible to the insulation of plug and socket.

**Table 1**

Nominal cross-sectional area admissible at contact mm <sup>2</sup>	Test cable nominal cross-sectional area mm <sup>2</sup>	Test current $\pm 0,5$ A	Temperature rise max. $^{\circ}\text{C}$
6	6	30	20
$2 \times 2,5$			
2,5	2,5	25	40
$2 \times 1,5$			
1,5	1,5	16	30

**3.5.2 Voltage drop test**

Take the measurements at a d.c. test current of 10 A, after thermal equilibrium. Determine the voltage drop at the connection from measurements at the measuring points shown in figure 5, with the voltage drops of the wires subtracted. The measuring points at the wires shall be outside the connector. Ensure that the parts of the cable where the insulation is removed do not influence the test results.

If possible, the voltage drop may additionally be measured across the terminals of the pins and their corresponding tubes.

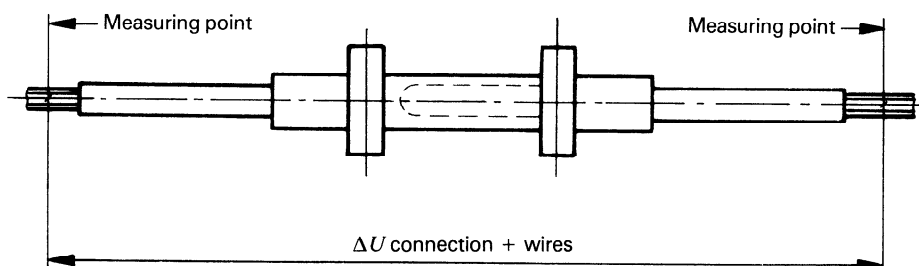

**Figure 5 — Voltage drop test measuring points**

iTeH STANDARD PREVIEW  
(standards.iteh.ai)  
ISO 4091:1992  
<https://standards.iteh.ai/catalog/standards/sis/9a61757d-ebaf-4967-b982-0dc55003d654/iso-4091-1992>



**3.5.3 Flash test**

Carry out the test with a test voltage of 1 000 V r.m.s. (50 Hz or 60 Hz) applied for at least 1 min, across the contacts, and between each contact and the case when metallic, or when it has additional metallic components.

**3.5.4 Current cycling test**

Carry out the current cycling test separately for each contact pair type of an assembled connector by applying 500 cycles as shown in figure 6 at a test current as in table 1. Connect a conductor of 500 mm ± 5 mm length and of a cross-sectional area as in table 1 to the terminals of the contacts under test.

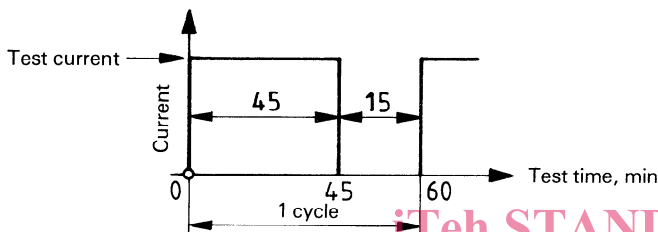

Figure 6 — Current cycling test

**3.6 Endurance test**

Carry out the test by subjecting the connector under test to 5 000 cycles (2 cycles/min) as follows:

- a) opening of the cover to 130° ± 5°;
- b) insertion of the plug into the socket;
- c) locking, allowing the cover to rest on the plug;
- d) unlocking (it may be necessary to lift the cover before unlocking due to the connector design);
- e) withdrawal of the plug, the cover closing by cover spring force.

Carry out insertions and withdrawals at a speed of 500 mm/min ± 100 mm/min.

**3.7 Test sequence**

The test sequence shall be as given in table 2.

The test sequences shall be carried out in the order of the running numbers listed in table 2 under the particular sample group. A test sequence shall be continued only if a sample meets the requirements specified in clause 4.

Table 2 — Test sequence

Reference subclause	Test title	Sample					
		A	B	C	D	E	F
3.2	Visual examination	1	1	1	1	1	1
4.2	Dimensional check	2					
3.3.3	Insertion	3	2	2		2	
3.3.4	Locking device operating test	4	3	3		3	
		8	10	8		8	
3.3.1	Static load	5					
3.3.2	Locking device and cable retention test	6					
3.3.9	Lateral strength at low temperature	7					
3.5.2	Voltage drop		4	4	2	4	2
			7	7	5	7	5
3.3.6	Salt spray test			5			
3.5.1	Current carrying capacity test				3		
3.5.4	Current cycling test				4		
3.5.3	Flash test		5	6		5	3
			9			11	6
3.6	Endurance test					6	
3.3.5	Vibration test						4
3.3.8	Temperature/humidity test		6				
3.3.3	Withdrawal	9	11	9		9	
3.3.7	Water splash test		8				10

**4 Performance requirements**

**4.1 Visual examination**

The samples shall comply with the particular specification of the connector.

**4.2 Dimensional check**

All of the dimensions shall be within the tolerances quoted in the particular specification of the connector. Failure of any of these dimensions to comply with these requirements entails the failure of the sample.

**4.3 Mechanical performance**

**4.3.1 Static load**

No cracks or permanent deformations shall be visible after the test as in 3.3.1.



**4.3.2 Locking device and cable retention strength**

No cracks or permanent deformations shall be visible after the test as in 3.3.2.

The test rod shall not have moved more than 2 mm after the test, measured on the PVC surface.

**4.3.3 Insertion and withdrawal force**

The force measured in the test in 3.3.3 shall not exceed 100 N.

**4.3.4 Locking device operating****4.3.4.1 Locking lever operating force**

The forces measured in the test in 3.3.4.1 shall not exceed 120 N.

**4.3.4.2 Twist-lock operating torque**

The torque measured in the test in 3.3.4.2 shall not exceed 3,5 N·m.

**4.3.5 Vibration resistance**

No cracks or permanent deformations shall be visible after the test as in 3.3.5.

NOTE 5 Contact resistance variation is under study.

**4.3.6 Salt spray resistance**

No marks of corrosion shall be visible after the test in 3.3.6.

**4.3.7 Water splash tightness**

No ingress of water shall be visible in the contact areas after the test in 3.3.7.

**4.3.8 Temperature/humidity stability**

No cracks or deformations shall be visible after the test in 3.3.8.

**4.3.9 Lateral strength at low temperature**

No cracks or permanent deformation shall be visible after the test in 3.3.9.

**4.4 Material specification**

All material used to construct the electrical connector shall be resistant to the subjects specified in 3.4.

NOTE 6 Resistance against solar radiation is under study.

**4.5 Electrical performance****4.5.1 Current carrying capacity**

The measured increase of contact temperature shall not exceed the appropriate temperature rise as specified in table 1.

**4.5.2 Voltage drop**

Each individual contact in the connector tested as in 3.5.2 shall show a maximum voltage drop of 40 mV.

**4.5.3 Flash test**

No flashover shall occur at the test in 3.5.3.

**4.5.4 Current cycling**

After the test in 3.5.4, voltage drop measurements shall be taken: a maximum voltage drop of 40 mV is allowed.

**4.6 Endurance test**

No cracks or permanent deformation shall be visible after 5 000 cycles as in 3.6.

iTeH STANDARD PREVIEW  
(standards.iteh.ai)

ISO 4091:1992

[https://standards.iteh.ai/catalog/standards/sist/1a6737e9-eba0-4969-b3d2-](https://standards.iteh.ai/catalog/standards/sist/1a6737e9-eba0-4969-b3d2-0dc55003d654/iso-4091-1992)

0dc55003d654/iso-4091-1992